



50G PAM4 SFP56 DWDM 80km (EDFA+DCM) Optical Transceiver

FBD-E50DxxK05T

Features

- Hot-pluggable SFP28 form factor
- Maximum link length of 80km
- Full-duplex transceiver module
- Up to 53.125Gbps (26.5625GBd PAM4)
- 53.125Gbps PAM4 based on a cooled EML TOSA transmitter
- 53.125Gbps PAM4 PIN Receiver
- Duplex LC receptacle
- Single 3.3V power supply
- Power dissipation < 3.1W
- RoHS compliant (lead free)
- Industrial case temperature range: -40°C to 85°C



Applications

- Optical Link

Description

The FIBERSTAMP Technologies FBD-E50DxxK05T is a single-Channel, Pluggable, Fiber-Optic SFP56 for 26.5625GBd PAM4 Ethernet Applications.. It is a high performance module are designed for 50GbE transmission up to 80km distance over standard G.652 single mode optical fibers (SMF). For short distances (< 5km) dispersion compensation is not required. For longer distances, EDFA and DCM are required to compensate the fiber link loss and fiber dispersion. The electrical interface uses a 20 contact edge type connector. The optical interface uses duplex LC receptacle. This module incorporates FIBERSTAMP Technologies proven circuit and technology to provide reliable long life, high performance, and consistent service.



Block Diagram

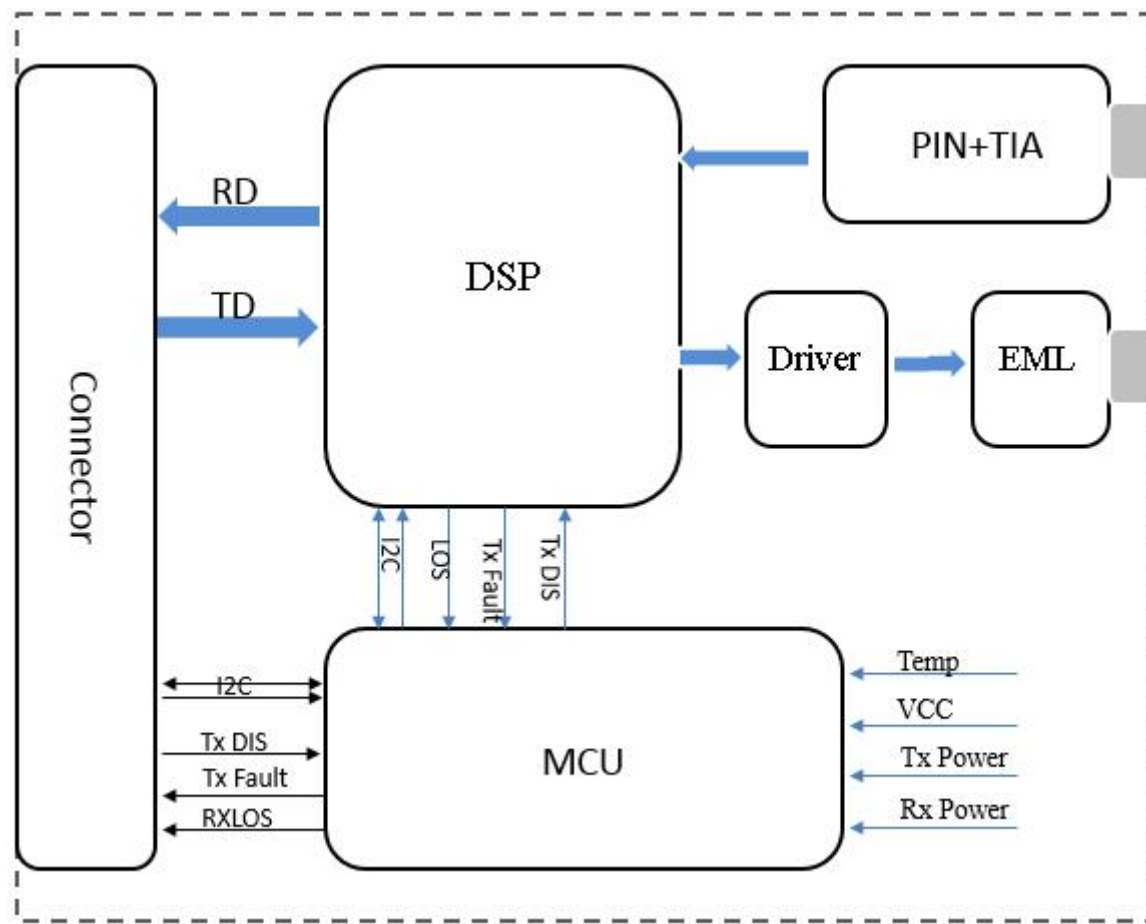

Absolute Maximum Ratings

Parameter	Symbol	Min	Max	Unit
Supply Voltage	Vcc	0	3.6	V
Storage Temperature	Ts	-40	+95	°C
Operating Humidity	-	5	85	%

Recommended Operating Conditions

Parameter	Symbol	Min	Typical	Max	Unit
Operating Case Temperature	Tc	-40		+85	°C
Power Supply Voltage	Vcc	3.13	3.3	3.47	V
Power Dissipation	Pm			3.1	W

Electrical Specifications

Parameter	Symbol	Min	Typical	Max	Unit
Differential Input Impedance	Zin	90	100	110	ohm
Differential Output Impedance	Zout	90	100	110	ohm
Differential Input Voltage Amplitude1	ΔV_{in}			900	mVp-p
Differential Output Voltage Amplitude2	ΔV_{out}			900	mVp-p
Input Logic Level High	V _{IH}	2.0		V _{cc}	V
Input Logic Level Low	V _{IL}	0		0.8	V
Output Logic Level High	V _{OH}	V _{cc} -0.5		V _{cc}	V
Output Logic Level Low	V _{OL}	0		0.4	V

Notes:

1. Differential input voltage amplitude is measured between TxnP and TxnN.
2. Differential output voltage amplitude is measured between RxnP and RxnN.

Optical Characteristics

Parameter	Symbol	Min	Typical	Max	Unit	Notes
Transmitter						
Optical Wavelength	λ_c	per ITU-T 694.1			nm	-
Center Wavelength Deviation	λ_d	±100			pm	
Side-mode suppression ratio	SMSR	30	-	-	dB	-
Average launch power	Pout	-4.5	-	4.2	dBm	-
Optical Modulation Amplitude(OMA outer)	OMA	-1.5	-	5	dBm	-
Transmitter and dispersion eye closure(TDEC)	TDEC	-	-	3.2	dB	
Extinction Ratio	ER	6	-	-	dB	-
Average launch power of OFF transmitter		-	-	-30	dB	-
Receiver						
Centre Wavelength	λ_c	1260		1600	nm	-
Receiver Sensitivity in OMA outer	RXsen	-	-12	-10	dBm	1
Average receive power	Pin	-11	-	5	dBm	-
Receiver Reflectance		-	-	-26	dB	-
LOS Assert		-	-16	-	dBm	-
LOS De-Assert		-	-14	-	dBm	-
LOS Hysteresis		0.5	-	-	dB	-

Note:

1. Measured with conformance test signal at TP3 for BER = 2.4E-4 Pre-FECs

DIAGNOSTIC MONITORING INTERFACE (OPTIONAL)

The following digital diagnostic characteristics are defined over the normal operating conditions unless otherwise specified.

Parameter	Symbol	Min	Max	Units	Notes
Temperature monitor absolute error	DMI_Temp	-3	+3	degC	Over operating temperature range
Supply voltage monitor absolute error	DMI_VCC	-0.1	0.1	V	Over full operating range
Channel RX power monitor absolute error	DMI_RX_Ch	-2	2	dB	1
Channel Bias current monitor	DMI_Ibias_Ch	-10%	10%	mA	
Channel TX power monitor absolute error	DMI_TX_Ch	-2	2	dB	1

Notes:

1. Due to measurement accuracy of different single mode fibers, there could be an additional +/-1 dB fluctuation, or a +/- 3 dB total accuracy.

2. The transceivers provide serial ID memory contents and diagnostic information about the present operating conditions by the 2-wire serial interface (SCL, SDA). The memory map specific data field defines as following.

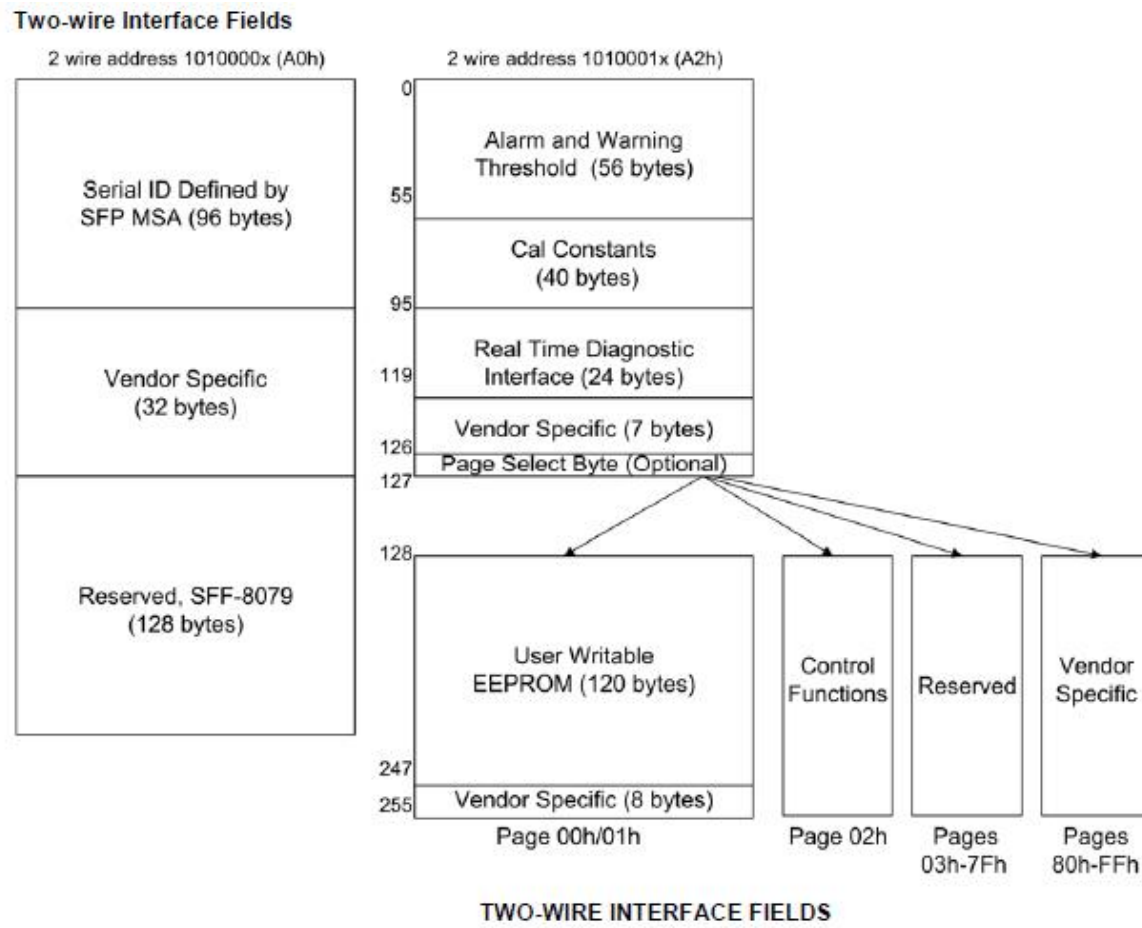

Pin Definitions

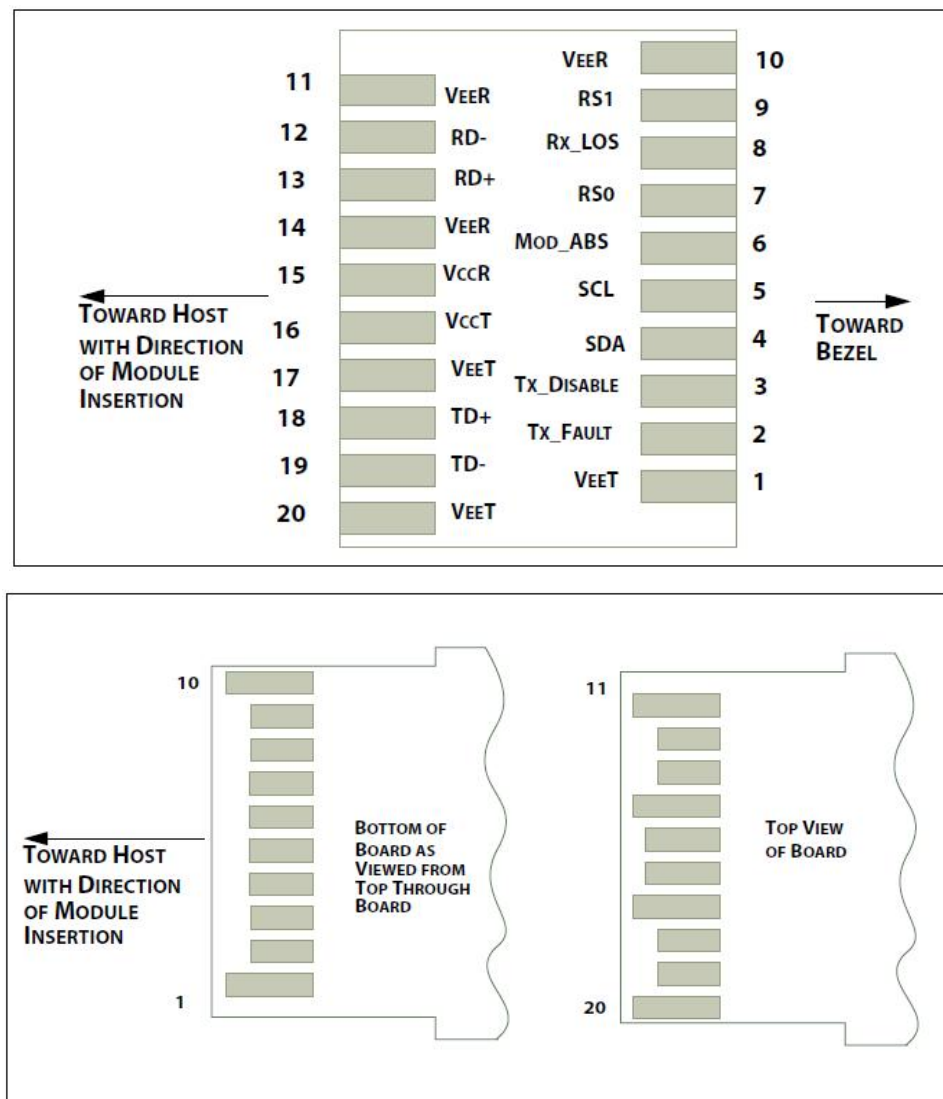

Pin Descriptions

PIN	Logic	Symbol	Name / Description	Note
1		VeeT	Module Transmitter Ground	1
2	LVTTL-O	TX_Fault	Module Transmitter Fault	2

PIN	Logic	Symbol	Name / Description	Note
3	LVTTTL-I	TX_Dis	Transmitter Disable; Turns off transmitter laser output	
4	LVTTTL-I/O	SDA	2-Wire Serial Interface Data Line	2
5	LVTTTL-I	SCL	2-Wire Serial Interface Clock	2
6		MOD_ABS	Module Definition, Grounded in the module	
7	LVTTTL-I	RS0	Receiver Rate Select	
8	LVTTTL-O	RX_LOS	Receiver Loss of Signal Indication Active LOW	
9	LVTTTL-I	RS1	Transmitter Rate Select (not used)	
10		VeeR	Module Receiver Ground	1
11		VeeR	Module Receiver Ground	1
12	CML-O	RD-	Receiver Inverted Data Output	
13	CML-O	RD+	Receiver Data Output	
14		VeeR	Module Receiver Ground	1
15		VccR	Module Receiver 3.3 V Supply	
16		VccT	Module Receiver 3.3 V Supply	
17		VeeT	Module Transmitter Ground	1
18	CML-I	TD+	Transmitter Non-Inverted Data Input	
19	CML-I	TD-	Transmitter Inverted Data Input	
20		VeeT	Module Transmitter Ground	1

Notes:

1. Module ground pins GND are isolated from the module case.
2. Shall be pulled up with 4.7K-10Kohms to a voltage between 3.15V and 3.45V on the host board.



Recommended Interface Circuit

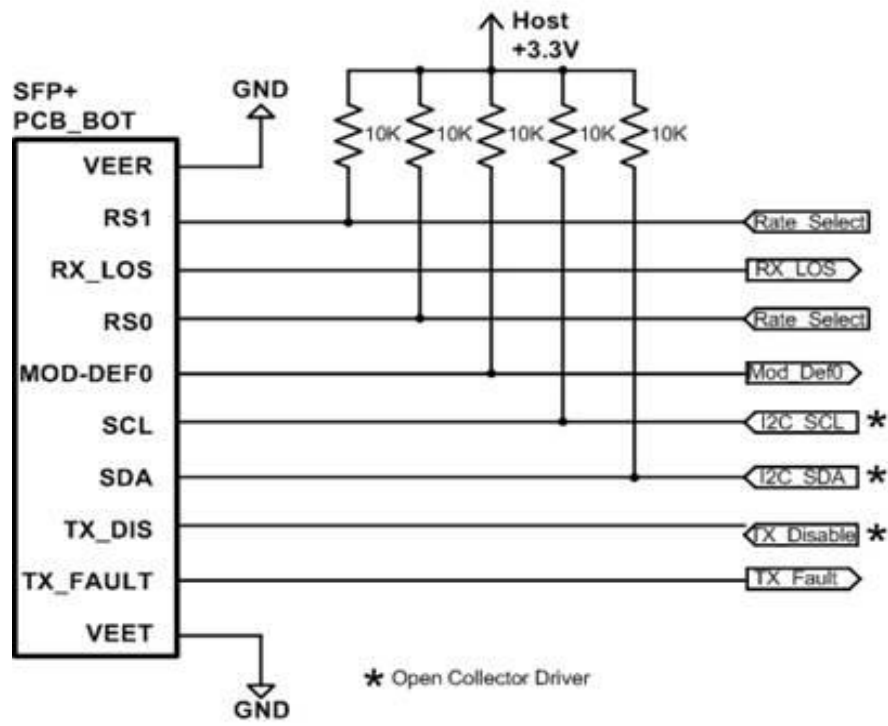
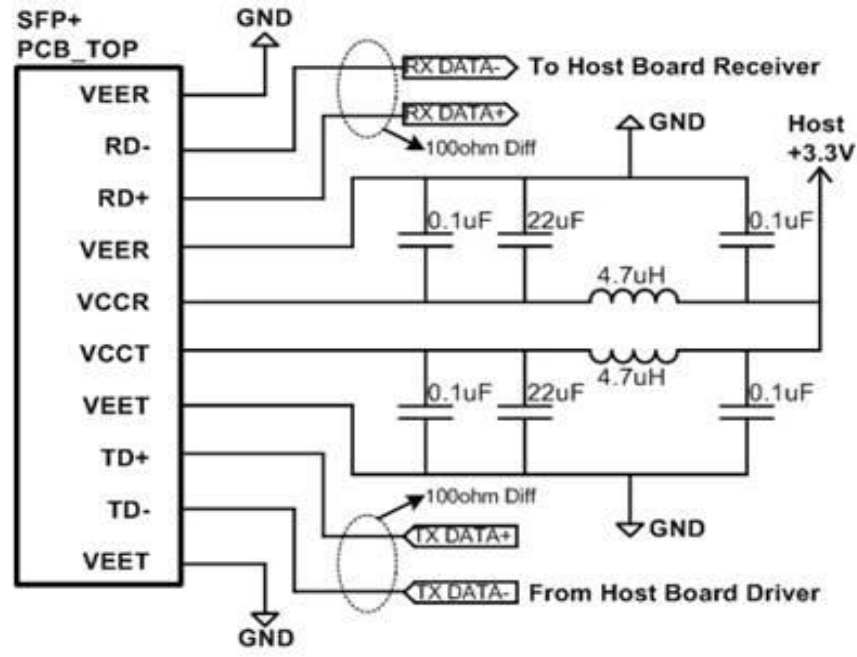

Mechanical Dimensions

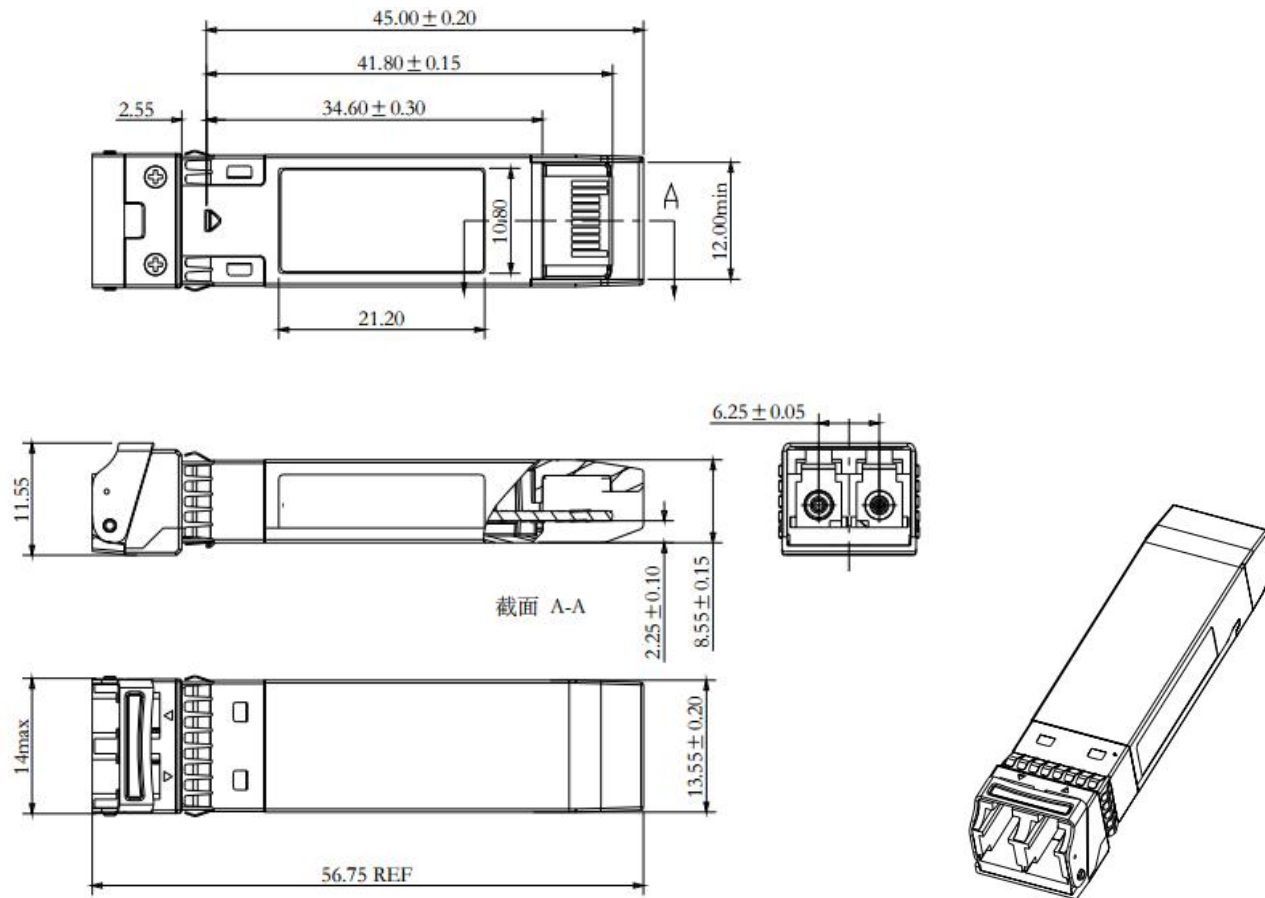

Regulatory Compliance

FIBERSTAMP FBD-E50DxxK05T transceivers are Class 1 Laser Products. They meet the requirements of the following standards:

Feature	Standard
Laser Safety	IEC 60825-1:2014 (3rd Edition) IEC 60825-2:2004/AMD2:2010 EN 60825-1-2014 EN 60825-2:2004+A1+A2
Electrical Safety	EN 62368-1: 2014 IEC 62368-1:2014 UL 62368-1:2014
Environmental protection	Directive 2011/65/EU with amendment(EU)2015/863
CE EMC	EN55032: 2015 EN55035: 2017 EN61000-3-2:2014 EN61000-3-3:2013
FCC	FCC Part 15, Subpart B; ANSI C63.4-2014

References

- SFP-8472 V12.3
- SFP-8431
- OIF CEI-56G-VSR-PAM4

⚠ CAUTION:

Use of controls or adjustment or performance of procedures other than those specified herein may result in hazardous radiation exposure.

Ordering information

Part Number	Product Description
FBD-E50DxxK05T	53Gbps, DWDM, 5km, -40° C ~ +85° C; xx : DWDM Channel NO.18~61.

Important Notice

Performance figures, data and any illustrative material provided in this data sheet are typical and must be specifically confirmed in writing by FIBERSTAMP before they become applicable to any particular order or contract. In accordance with the FIBERSTAMP policy of continuous improvement specifications may change without notice.

The publication of information in this data sheet does not imply freedom from patent or other protective rights of FIBERSTAMP or others. Further details are available from any FIBERSTAMP sales representative.

