

# 40G QSFP+ to 40G QSFP+ Passive Direct-Attached Copper Cables

## FWF-E40xxxxxC

### Features

- QSFP+ conforms to the Small Form Factor SFF-8436
- 4-Channel Full-Duplex Passive Copper Cable Transceiver
- Support for multi-gigabit data rates :1Gb/s - 10Gb/s (per channel)
- Maximum aggregate data rate: 40Gb/s (4x10Gb/s)
- Copper link length up to 5m (passive limiting)
- High-Density QSFP 38-PIN Connector
- Power Supply :+3.3V
- Low power consumption: 0.02 W (typ.)
- I<sup>2</sup>C based two-wire serial interface for EEPROM signature which can be customized
- Temperature Range: 0~ 70°C



### Applications

- 10 Gigabit Ethernet
- 40 Gigabit Ethernet
- InfiniBand4x SDR, DDR, QDR
- 2, 4, 8, 10 Gigabit Fiber Channel
- Fiber Channel over Ethernet
- SAS,Servers,Hubs,Switches,Routers

### STANDARDS COMPLIANCE

- IEEE 802.3ba
- SFF-8436
- InfiniBand
- QSFP+ MSA
- RoHS Compliant

### Product Description

The QSFP+ passive cable assemblies are high performance, cost effective I/O solutions for 40G LAN, HPC and SAN applications. The QSFP+ passive copper cables are compliant with SFF-8436, QSFP+ MSA and IEEE P802.3ba 40GBASE-CR4. It is offer a low power consumption, short reach intercon- nect applications. The cable each lane is capable of transmitting data at rates up to 10Gb/s, providing an aggregated rate of 40Gb/s.



## Recommended Operating Conditions

Parameter	Symbol	Min	Typical	Max	Unit
Storage Ambient Temperature		-40		+85	°C
Operating Case Temperature	Tc	0		+70	°C
Power Supply Voltage	VCC3	3.14	3.3	3.47	V
Power Dissipation	PD			0.02	W

## Mechanical Dimensions

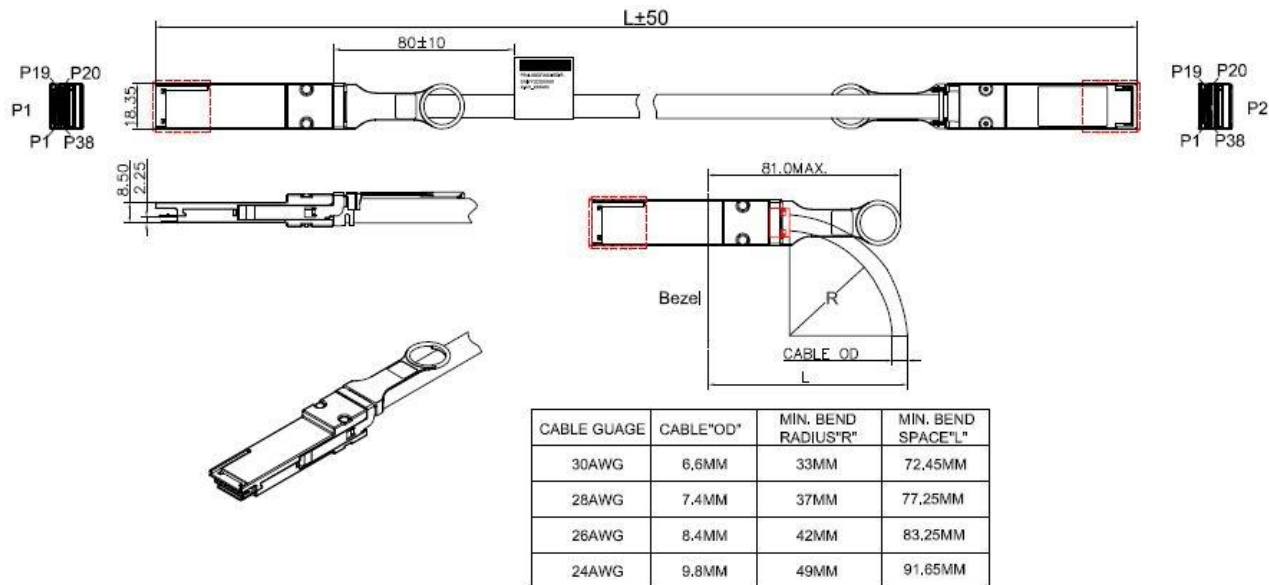

## QSFP+ Host Board Schematic for passive copper cables

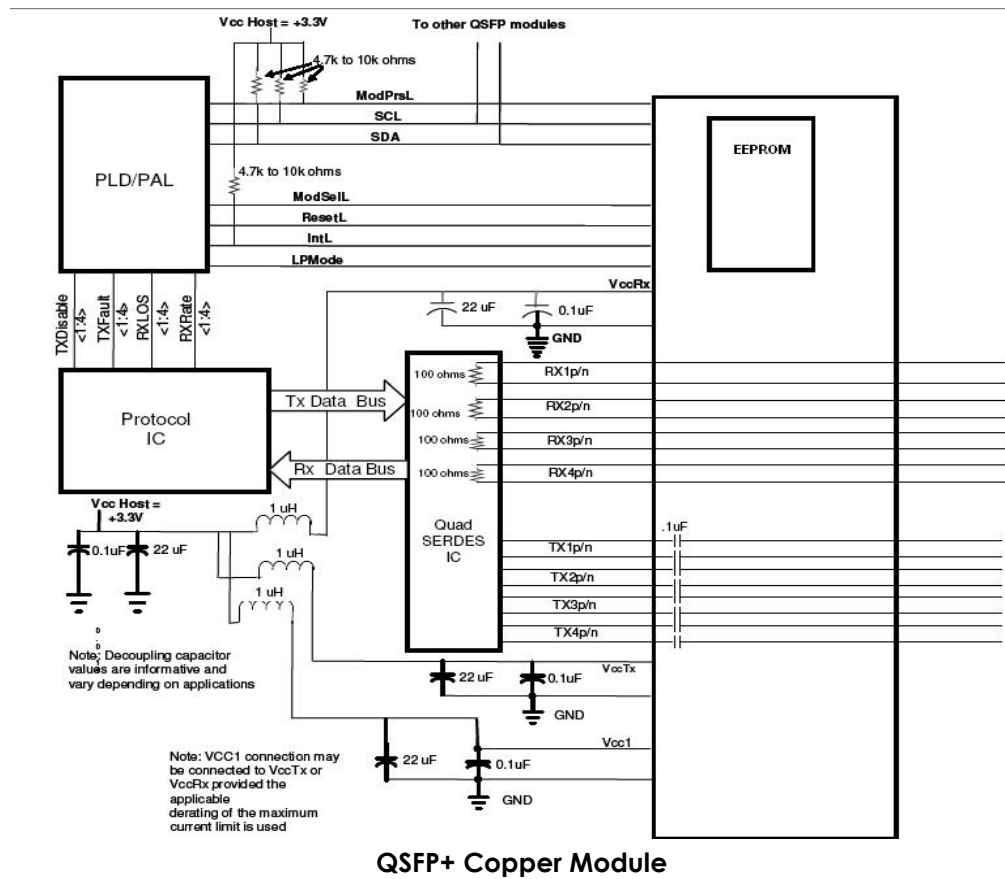

## Pin Descriptions

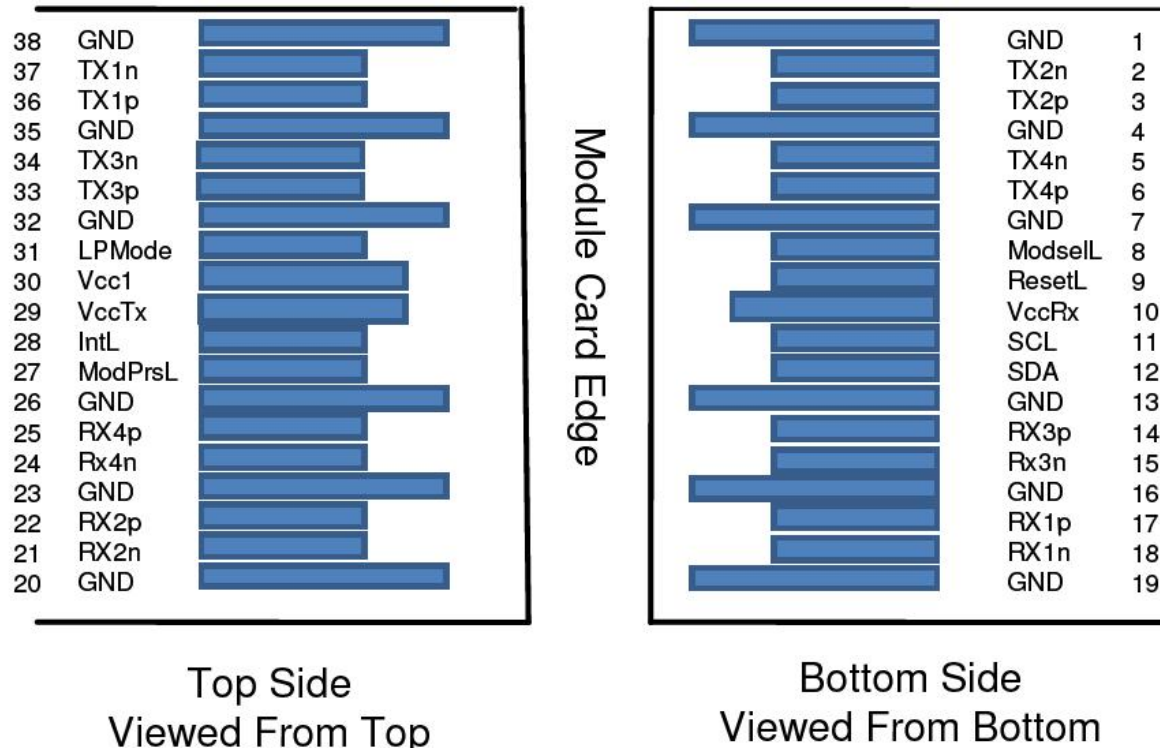

Pin	Logic	Symbol	Name/Description	Notes
1		GND	Ground	1
2	CML-I	Tx2n	Transmitter Inverted Data Input	
3	CML-I	Tx2p	Transmitter Non-Inverted Data Input	
4		GND	Ground	1
5	CML-I	Tx4n	Transmitter Inverted Data Input	
6	CML-I	Tx4p	Transmitter Non-Inverted Data Input	
7		GND	Ground	1
8	LVTTTL-I	ModSelL	Module Select	
9	LVTTTL-I	ResetL	Module Reset	
10		Vcc Rx	+3.3V Power Supply Receiver	2
11	LVCMOSI/O	SCL	2-wire serial interface clock	
12	LVCMOSI/O	SDA	2-wire serial interface data	
13		GND	Ground	1
14	CML-O	Rx3p	Receiver Non-Inverted Data Output	
15	CML-O	Rx3n	Receiver Inverted Data Output	
16		GND	Ground	1
17	CML-O	Rx1p	Receiver Non-Inverted Data Output	
18	CML-O	Rx1n	Receiver Inverted Data Output	
19		GND	Ground	1
20		GND	Ground	1
21	CML-O	Rx2n	Receiver Inverted Data Output	
22	CML-O	Rx2p	Receiver Non-Inverted Data Output	
23		GND	Ground	1
24	CML-O	Rx4n	Receiver Inverted Data Output	
25	CML-O	Rx4p	Receiver Non-Inverted Data Output	

Pin	Logic	Symbol	Name/Description	Notes
26		GND	Ground	1
27	LVTTTL-O	ModPrsL	Module Present	
28	LVTTTL-O	IntL	Interrupt	
29		Vcc Tx	+3.3V Power supply transmitter	2
30		Vcc1	+3.3V Power supply	2
31	LVTTTL-I	LPMode	Low Power Mode	
32		GND	Ground	1
33	CML-I	Tx3p	Transmitter Non-Inverted Data Input	
34	CML-I	Tx3n	Transmitter Inverted Data Input	
35		GND	Ground	1
36	CML-I	Tx1p	Transmitter Non-Inverted Data Input	
37	CML-I	Tx1n	Transmitter Inverted Data Input	
38		GND	Ground	1

**Note:**

1. GND is the symbol for signal and supply (power) common for the QSFP+ module. All are common within the QSFP+ module and all module voltages are referenced to this potential unless otherwise noted. Connect these directly to the host board signal-common ground plane.
2. Vcc Rx, Vcc1 and Vcc Tx are the receiver and transmitter power supplies and shall be applied concurrently. Requirements defined for the host side of the Host Edge Card Connector are listed in Table 6. Recommended host board power supply filtering is shown in Figure 4. Vcc Rx Vcc1 and Vcc Tx may be internally connected within the QSFP+ Module module in any combination. The connector pins are each rated for a maximum current of 500 mA.

**Ordering information**

Part Number	FWF-E40xxxxxC					
Length (meter)	1	2	3	4	5	6
Wire gauge (AWG)	30	30	30	26	26	26

**Important Notice**

Performance figures, data and any illustrative material provided in this data sheet are typical and must be specifically confirmed in writing by FIBERSTAMP before they become applicable to any particular order or contract. In accordance with the FIBERSTAMP policy of continuous improvement specifications may change without notice. The publication of information in this data sheet does not imply freedom from patent or other protective rights of FIBERSTAMP or others. Further details are available from any FIBERSTAMP sales representative.

