

40GE/OTU3 QSFP+ LR4 1310nm 10km Optical Transceiver Module

Features

- Hot-pluggable QSFP+ form factor
- 4 channels full-duplex transceiver module
- 4x uncooled CWDM DFB lasers with AAWG MUX
- High-sensitivity PIN-TIA with AAWG DEMUX
- Compliant with QSFP MSA, IEEE 802.3ba 40GBASE-LR4 and OTN OTU3
- Data rate up to 44.6Gbps
- Reach up to 10km over SMF
- Power consumption < 3.5W
- Duplex LC receptacles
- Operating case temperature range from 0°C to 70°C
- 3.3V power supply voltage
- RoHS compliant (lead free)



Applications

- 40G Ethernet and OTU3, OTU3e1, OTU3e2
- Infiniband QDR and DDR interconnects
- Client-side 40G Telecom connections

Description

The 40GE/OTU3 QSFP+ LR4 1310nm 10km Optical Transceiver Module is a 4x10G hot pluggable optical transceiver. The FiberStamp enables the integration of 4 transmitters, 4 receivers and an optical MUX/DeMUX with AAWG into a small form factor package that delivers a 40 Gbps data link in a compact QSFP footprint. The optical connectivity is based on two SMF LC connectors, one for Tx and one for Rx. The Tx and Rx each consist of 4 10Gb/s CWDM channels, whose wavelengths are in the 1300nm range. The QSFP-LR transceiver is designed for applications based on the QSFP MSA, IEEE 802.3ba, 40GBASE-LR4 and OTU3 C4S1-2D1 requirements specified in ITU-T recommendation G.695 of up to 10km reach.

Functional Block Diagram

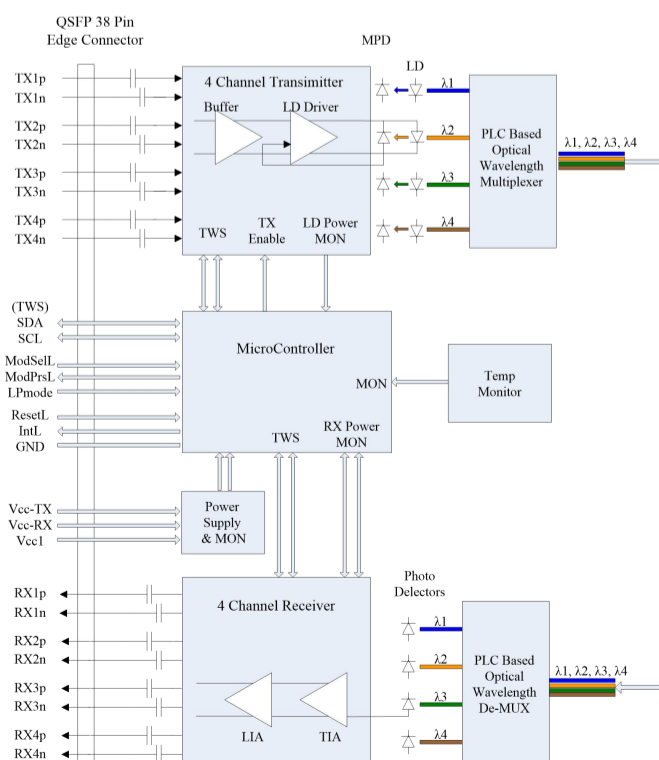

Figure 1: Functional Block Diagram



Absolute Maximum Ratings

Parameter	Symbol	Min	Max	Unit
Supply Voltage	Vcc-Tx Vcc-Rx Vcc1	-0.5	3.6	V
Storage Temperature Range	TSTG	-40	+85	°C
Maximum Average Input Optical Power per lane (Damage Threshold)	PIN	3.4		dBm
Relative Humidity	RH	10% to 90% (non-condensing)		

Operating Conditions

Parameter	Symbol	Min	Max	Unit
Supply Voltage	Vcc-Tx Vcc-Rx Vcc1	3.1	3.5	V
Operating Case temperature	TCASE	0	70	°C
Power Consumption	PDISS		3.5	W
SMF Link Length	LKM		10	km

High Speed Electrical Specifications

Parameter	Min	Typical	Max	Units
General				
Supply Voltage	3.1	3.3	3.5	Volts
Supply Current			1.0	Amps
Maximum Power Consumption			3.5	Watts
Maximum Power Consumption – LP Mode			1.5	Watts
Signaling Speed Per Channel			11.2	Gb/s
Transmitter				
Transmitter Differential Input Impedance		100		ohms
Transmitter Differential Input Voltage	120		1200	mVpp
Transmitter Signaling Speed Operating Range		±20		ppm
Receiver				
Differential Output impedance		100		ohms
Receiver Signaling Speed Operating Range		±100		ppm
Differential output voltage		300	850	mV
Rise Time			60	ps
Fall Time			60	ps



Optical Characteristics

Transmitter Specifications – Optical

Parameter	Min	Typical	Max	Unit
Lane Wavelength Range	1264.5 1284.5 1304.5 1324.5	1271 1291 1311 1331	1277.5 1297.5 1317.5 1337.5	nm
Data Rate Per Lane			11.2	Gb/s
Average Optical power per lane	-2.3		2.3	dBm
Total Average Launch power			8.3	dBm
Optical Modulation Amplitude (OMA), each lane	-4		3.5	dBm
Extinction Ratio	4.5			dB
Difference in launch power between any two lanes			6.5	dB
Relative Intensity Noise (RIN)			-128	dB/Hz
Launch Power in OMA minus TDP, each lane	-4.8			dBm
Transmitter and dispersion penalty (TDP), each lane			2.6	dB
Side-Mode Suppression Ratio (SMSR)	30			dB
Average Launch Power per lane @ TX off state			-30	dBm
Transmitter Reflectance			-12	dB
Optical return loss tolerance			20	dB
Transmitter Eye Mask definition: X1, X2, X3, Y1, Y2, Y3	Compliant with 802.3ba standard {0.25, 0.4, 0.45, 0.25, 0.28, 0.4}			
Eye Mask Criteria	5% mask margin over specified ranges of temperature, voltage and power supply noise at end of life.			



Receiver Specifications – Optical

Parameter	Min	Typical	Max	Unit
Lane Wavelength Range	1264.5 1284.5 1304.5 1324.5	1271 1291 1311 1331	1277.5 1297.5 1317.5 1337.5	nm
Damage Threshold			3.4	dBm
Average Receive Power, each lane	-13.7		2.3	dBm
Receive Power, each lane (OMA)			3.5	dBm
Difference in Receive Power between any two lanes (OMA)			7.5	dB
Receiver Reflectance			-26	dB
Receiver Sensitivity (OMA) per lane (@ PRBS 231-1 and BER=10 ⁻¹²)			-11.5	dBm
Receiver 3 dB electrical upper cutoff frequency, each lane			12.3	GHz
Stressed Receiver Sensitivity (OMA), each lane			-9.6	dBm
RX_LOS_Assert Min/Max	-30			dBm
RX_LOS_De-Assert Max			-14	dBm
RX_LOS_Hysteresis	0.5			dB

Recommended Host Board Power Supply Filtering

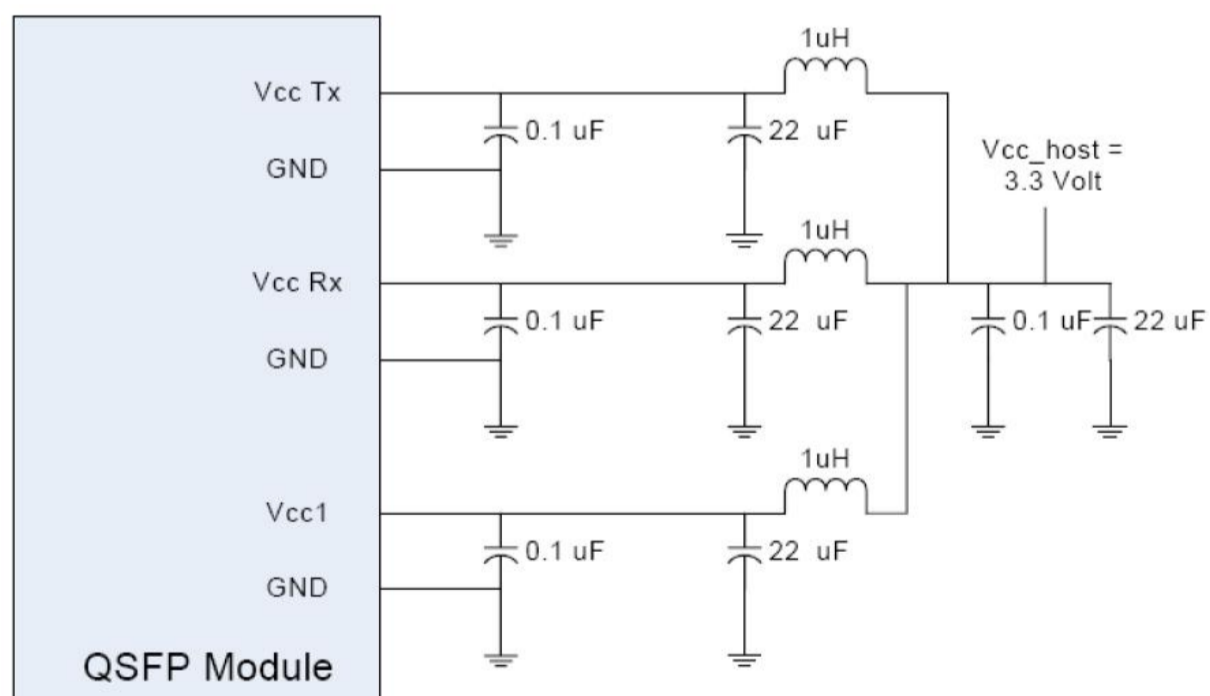

Figure 2. QSFP voltage supply and filtering scheme



Pin Descriptions

Pin	Logic	Symbol	Name/Description	Ref.
1		GND	Module Ground	1
2	CML-I	Tx2-	Transmitter inverted data input	
3	CML-I	Tx2+	Transmitter non-inverted data input	
4		GND	Module Ground	1
5	CML-I	Tx4-	Transmitter inverted data input	
6	CML-I	Tx4+	Transmitter non-inverted data input	
7		GND	Module Ground	1
8	LVTTTL-I	MODSEIL	Module Select	2
9	LVTTTL-I	ResetL	Module Reset	2
10		VCCRx	+3.3v Receiver Power Supply	
11	LVC MOS-I	SCL	2-wire Serial interface clock	2
12	LVC MOS-I/O	SDA	2-wire Serial interface data	2
13		GND	Module Ground	1
14	CML-O	RX3+	Receiver non-inverted data output	
15	CML-O	RX3-	Receiver inverted data output	
16		GND	Module Ground	1
17	CML-O	RX1+	Receiver non-inverted data output	
18	CML-O	RX1-	Receiver inverted data output	
19		GND	Module Ground	1
20		GND	Module Ground	1
21	CML-O	RX2-	Receiver inverted data output	
22	CML-O	RX2+	Receiver non-inverted data output	
23		GND	Module Ground	1
24	CML-O	RX4-	Receiver inverted data output	
25	CML-O	RX4+	Receiver non-inverted data output	
26		GND	Module Ground	1
27	LVTTTL-O	ModPrsL	Module Present, internal pulled down to GND	
28	LVTTTL-O	IntL	Interrupt output, should be pulled up on host board	2
29		VCCTx	+3.3v Transmitter Power Supply	
30		VCC1	+3.3v Power Supply	
31	LVTTTL-I	LPMODE	Low Power Mode	2
32		GND	Module Ground	1
33	CML-I	Tx3+	Transmitter non-inverted data input	
34	CML-I	Tx3-	Transmitter inverted data input	



Pin	Logic	Symbol	Name/Description	Ref.
35		GND	Module Ground	1
36	CML-I	Tx1+	Transmitter non-inverted data input	
37	CML-I	Tx1-	Transmitter inverted data input	
38		GND	Module Ground	1

Notes:

1. Module circuit ground is isolated from module chassis ground within the module.
2. Open collector; should be pulled up with 4.7k – 10k ohms on host board to a voltage between 3.15V and 3.6V.

QSFP Edge Connector and Pinout Description

The electrical interface to the transceiver is a 38-pin edge connector. The 38-pins provide high speed data, low speed monitoring and control signals, I²C communication, power and ground connectivity. The top and bottom views of the connector are provided below, as well as a table outlining the contact numbering, symbol and full description.

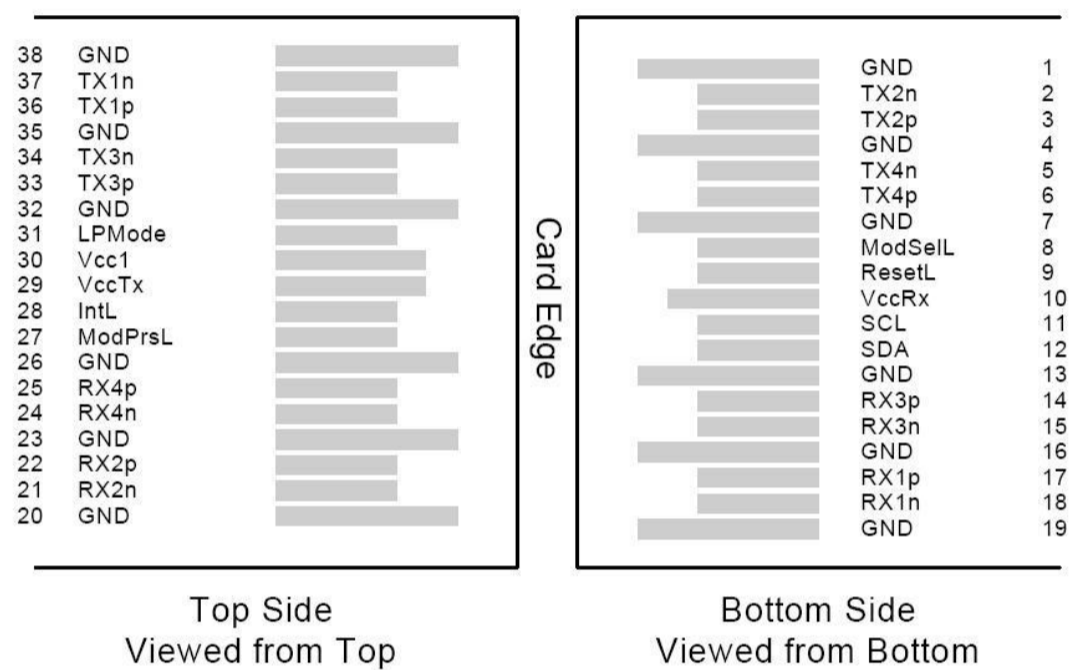

ModSelL Pin

The ModSelL is an input pin. When held low by the host, the module responds to 2-wire serial communication commands. The ModSelL allows the use of multiple QSFP modules on a single 2-wire interface bus. When the ModSelL is “High”, the module will not respond to any 2-wire interface communication from the host. ModSelL has an internal pull-up in the module.

ResetL Pin

Reset. LPMODE_Reset has an internal pull-up in the module. A low level on the ResetL pin for longer than the minimum pulse length (t_{Reset_init}) initiates a complete module reset, returning all user module settings to their default state. Module Reset Assert Time (t_{init}) starts on the rising edge after the low level on the ResetL pin is released. During the execution of a reset (t_{init}) the host shall disregard all status bits until the module indicates a completion of the reset interrupt. The module indicates this by posting an IntL signal with the Data_Not_Ready bit negated. Note that on power up (including hot insertion) the module will post this completion of reset interrupt without requiring a reset.

LPMODE Pin

FiberStamp QSFP PSM LR4 operate in the low power mode (less than 1.5 W power consumption) This pin active high will decrease power consumption to less than 1W.

LPMODE	Power_Override Bit	Power_set Bit	Module Power Allowed
1	0	X	Low Power (< 1.5W)
0	0	X	High Power (< 3.5W)
X	1	1	Low Power (< 1.5W)
X	1	0	High Power (< 3.5W)



ModPrsL Pin

ModPrsL is pulled up to Vcc on the host board and grounded in the module. The ModPrsL is asserted "Low" when the module is inserted and deasserted "High" when the module is physically absent from the host connector.

IntL Pin

IntL is an output pin. When "Low", it indicates a possible module operational fault or a status critical to the host system. The host identifies the source of the interrupt by using the 2-wire serial interface. The IntL pin is an open collector output and must be pulled up to Vcc on the host board.

The timing for QSFP Soft Control and Status Functions are described as follows:

Parameter	Symbol	Max	Unit	Conditions
Initialization Time	t_init	2000	ms	Time from power on ² , hot plug or rising edge of Reset until the module is fully functional ³ This time does not apply to non-Power Level 0 modules in the Low Power State
Reset Init Assert Time	t_reset_init	2	μs	A Reset is generated by a low level longer than the minimum reset pulse time present on the ResetL pin.
Serial Bus Hardware Ready Time	t_serial	2000	ms	Time from power on ² until module responds to data transmission over the 2-wire serial bus
Monitor Data Ready Time	t_data	2000	ms	Time from power on ² to data not ready, bit 0 of Byte 2, deasserted and IntL asserted
Reset Assert Time	t_reset	2000	ms	Time from rising edge on the ResetL pin until the module is fully functional ³
LPMODE Assert Time	ton_LPMODE	100	μs	Time from assertion of LPMODE (Vin:LPMODE = Vih) until module power consumption enters lower Power Level 1
LPMODE Deassert Time	Toff_LPMODE	300	ms	Time for deassertion of LPMODE (Vin:LPMODE=Vil) until module is fully functional ^{3,5}
IntL Assert Time	ton_IntL	200	ms	Time from occurrence of condition triggering IntL until Vout:IntL = Vol
IntL Deassert Time	toff_IntL	500	μs	Time from clear on read ⁴ operation of associated flag until Vout:IntL = Voh. This includes deassert times for Rx LOS, Tx Fault and other flag bits.
Rx LOS Assert Time	ton_los	100	ms	Time from Rx LOS state to Rx LOS bit set (value=1b) and IntL asserted
Tx Fault Assert Time	ton_Txfault	200	ms	Time from Tx Fault state to Tx Fault bit set (value=1b) and IntL asserted
Flag Assert Time	ton_flag	200	ms	Time from occurrence of condition triggering flag to associated flag bit set (value=1b) and IntL asserted
Mask Assert Time	ton_mask	100	ms	Time from mask bit set(value=1b) ¹ until associated IntL assertion is inhibited
Mask Deassert Time	toff_mask	100	ms	Time from mask bit cleared (value=0b) ¹ until associated IntL operation resumes



Parameter	Symbol	Max	Unit	Conditions
Application or Rate Select Change Time	t_ratesel	100	µs	Time from change of state of Application or Rate Select Bit1 until transmitter or receiver bandwidth is in conformance with appropriate specification
Power_override or Power-set Assert Time	ton_Pdown	100	ms	Time from P_Down bit set (value=1b)1 until module power consumption enters lower Power Level 1
Power_override or Power-set Deassert Time	toff_Pdown	300	ms	Time from P_Down bit cleared(value=0b)1 until the module is fully functional3

Notes:

1. Measured from falling clock edge after stop bit of read transaction.
2. Power on is defined as the instant when supply voltages reach and remain at or above the minimum level specified value.
3. Fully functional is defined as IntL asserted due to data not ready bit, bit 0 byte 2 deasserted. The module should also meet optical and electrical specifications
4. Measured from falling clock edge after stop bit of write transaction.

Squelch and disable timings are defined in the table below:

Parameter	Symbol	Max	Unit	Conditions
Rx Squelch Assert Time	ton_Rxsq	80	us	Time from loss of Rx input signal until the squelched output condition is reached.
Rx Squelch Deassert Time	toff_Rxsq	80	us	Time from resumption of Rx input signals until normal Rx output condition is reached.
Tx Squelch Assert Time	ton_Txsq	400	ms	Time from loss of Tx input signal until the squelched output condition is reached.
Tx Squelch Deassert Time	toff_Txsq	400	ms	Time from resumption of Tx input signals until normal Tx output condition is reached.
Tx Disable Assert Time	ton_txdis	100	ms	Time from Tx Disable bit set (value = 1b)1 until optical output falls below 10% of nominal
Tx Disable Deassert Time	toff_txdis	400	ms	Time from Tx Disable bit cleared (value = 0b)1 until optical output rises above 90% of nominal
Rx Output Disable Assert Time	ton_rxdis	100	ms	Time from Rx Output Disable bit set (value = 1b)1 until Rx output falls below 10% of nominal
Rx Output Disable Deassert Time	toff_rxdis	100	ms	Time from Rx Output Disable bit cleared (value = 0b)1 until Rx output rises above 90% of nominal
Squelch Disable Assert Time	ton_sqdis	100	ms	This applies to Rx and Tx Squelch and is the time from bit set (value = 0b)1 until squelch functionality is disabled.
Squelch Disable Deassert Time	toff_sqdis	100	ms	This applies to Rx and Tx Squelch and is the time from bit cleared (value = 0b)1 until squelch functionality is enabled

Notes:

1. Measured from falling clock edge after stop bit of read transaction.



QSFP Module Memory Map Description

The QSFP Memory Map, shown in figure 4 below, is used for serial ID, digital monitoring and certain control functions. The memory structure is arranged into a lower, single address space of 128 bytes (0-127) and multiple upper address space pages. The structure permits timely access to address in the lower page such as Interrupt Flags, Monitors, Control and various alarms. The upper memory pages are used for less time critical tasks such as ID information fields, Vendor ID, and various module and channels thresholds to activate various alarms. The lower page and Upper page 00 is always implemented. Upper page 01 is optional and currently not available. Upper page 02 is optional and implemented. Upper page 03 is implemented.

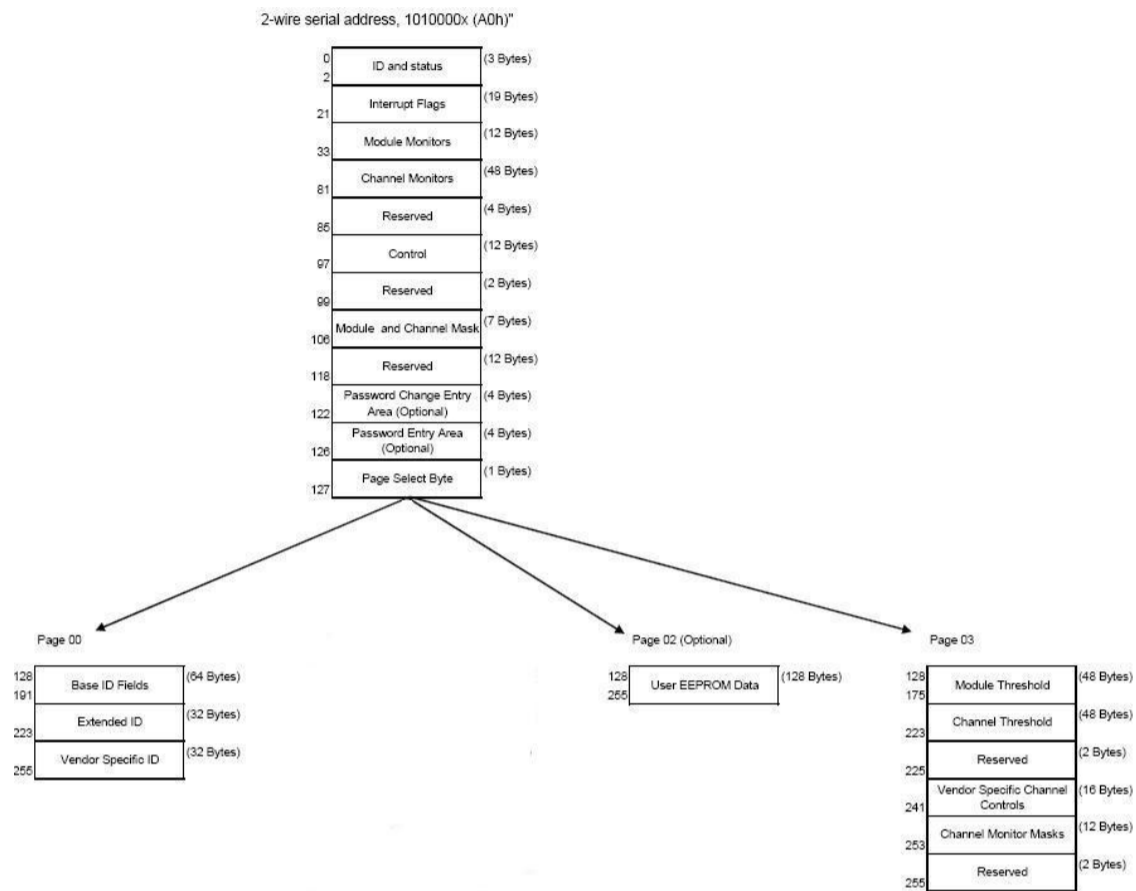

Figure 4. QSFP Memory Map

Lower Memory Map Description

The lower 128 bytes of the 2-wire serial bus address space is used to access a variety of measurements and diagnostic functions, a set of control functions, and a means to select which of the various upper memory map pages are accessed on subsequent reads. This portion of the address space is always directly addressable and thus is chosen for monitoring and control functions that may need to be repeatedly accessed. The definition of Identifier field is the same as page 00h Byte 128.

Lower Memory Map of the QSFP+ module.

Byte Address	Description	Type
0	Identifier(1 Byte)	Read Only
1-2	Status(2 Bytes)	Read Only
3-21	Interrupt Flags(19 Bytes)	Read Only
22-33	Module Monitors(12Bytes)	Read Only
34-81	Channel Monitors(48 Bytes)	Read Only
82-85	Reserved (4 Bytes)	Read Only
86-97	Control(12Bytes)	Read/Write
98-99	Reserved(2 Bytes)	Read/Write
100-106	Module and Channel Masks (7 Bytes)	Read/Write
107-126	Reserved (12 Bytes)	Read/Write
127	Page Select Byte	Read/Write



Status Indicator Bits

Byte	Bit	Name	Description
Status Indicators			
0	All	Identifier (1 Byte)	Equal to 0Dh
1	All	Reserved	
2	7	Reserved	
	6	Reserved	
	5	Reserved	
	4	Reserved	
	3	Reserved	
	2	Flat_Mem	Upper memory flat (= '0') or paged ('1'). It set high = '1'.
	1	IntL	Digital state of the IntL interrupt output pin.
	0	Data_Not_Ready	Indicates transceiver has not yet achieved power up and monitor data is not ready. Bit remains high until data is ready to be read at which time the device sets the bit low.

The Data_Not_Ready bit is high during module power up and prior to a valid suite of monitor readings. Once all monitor readings are valid, the bit is set low until the device is powered down.

Channel Status Interrupt Flags

A portion of the memory map (Bytes 3 through 21), form a flag field. Within this field, the status of LOS and Tx Fault as well as alarms and warnings for the various monitored items is reported. In normal conditions, the bits in this field are set to '0'. For the defined conditions of LOS, Tx Fault, module and channel alarms, the appropriate bit or bits are set to '1'.

The Channel Status Interrupt Flags, Module Monitor Interrupt Flags and Channel Monitor Interrupt Flags are defined below.

Byte	Bit	Name	Description
Channel Status Interrupt Flags			
3	7-4	Reserved	
	3	Rx4 LOS	Latched RX LOS indicator, channel 4
	2	Rx3 LOS	Latched RX LOS indicator, channel 3
	1	Rx2 LOS	Latched RX LOS indicator, channel 2
	0	Rx1 LOS	Latched RX LOS indicator, channel 1
4	7-4	Reserved	
	3	Tx4 Fault	Latched TX fault indicator, channel 4
	2	Tx3 Fault	Latched TX fault indicator, channel 3
	1	Tx2 Fault	Latched TX fault indicator, channel 2
	0	Tx1 Fault	Latched TX fault indicator, channel 1
5	All	Reserved	

Notes: A portion of the memory map (Bytes 3 through 21), form a flag field. Within this field, the status of LOS and Tx Fault as well as alarms and warnings for the various monitored items is reported. In normal conditions, the bits in this field are set to '0'. For the defined conditions of LOS, Tx Fault, module and channel alarms, the appropriate bit or bits are set to '1'.



Byte	Bit	Name	Description
Module Monitor Interrupt Flags			
6	7	L-Temp High Alarm	Latched high temperature alarm
	6	L-Temp Low Alarm	Latched low temperature alarm
	5	L-Temp High Warning	Latched high temperature warning
	4	L-Temp Low Warning	Latched low temperature warning
	3-0	Reserved	
7	7	L-Vcc High Alarm	Latched high supply voltage alarm
	6	L-Vcc Low Alarm	Latched low supply voltage alarm
	5	L-Vcc High Warning	Latched high supply voltage warning
	4	L-Vcc Low Warning	Latched low supply voltage warning
	3-0	Reserved	
8	All	Reserved	
Channel Monitor Interrupt Flags			
9	7	L-Rx1 Power High Alarm	Latched high RX power alarm, channel 1
	6	L-Rx1 Power Low Alarm	Latched low RX power alarm, channel 1
	5	L-Rx1 Power High Warning	Latched high RX power warning, channel 1
	4	L-Rx1 Power Low Warning	Latched low RX power warning, channel 1
	3	L-Rx2 Power High Alarm	Latched high RX power alarm, channel 2
	2	L-Rx2 Power Low Alarm	Latched low RX power alarm, channel 2
	1	L-Rx2 Power High Warning	Latched high RX power warning, channel 2
	0	L-Rx2 Power Low Warning	Latched low RX power warning, channel 2
10	7	L-Rx3 Power High Alarm	Latched high RX power alarm, channel 3
	6	L-Rx3 Power Low Alarm	Latched low RX power alarm, channel 3
	5	L-Rx3 Power High Warning	Latched high RX power warning, channel 3
	4	L-Rx3 Power Low Warning	Latched low RX power warning, channel 3
	3	L-Rx4 Power High Alarm	Latched high RX power alarm, channel 4
	2	L-Rx4 Power Low Alarm	Latched low RX power alarm, channel 4
	1	L-Rx4 Power High Warning	Latched high RX power warning, channel 4
	0	L-Rx4 Power Low Warning	Latched low RX power warning, channel 4
11	7	L-Tx1 Bias High Alarm	Latched high TX Bias alarm, channel 1
	6	L-Tx1 Bias Low Alarm	Latched low TX Bias alarm, channel 1
	5	L-Tx1 Bias High Warning	Latched high TX Bias warning, channel 1
	4	L-Tx1 Bias Low Warning	Latched low TX Bias warning, channel 1
	3	L-Tx2 Bias High Alarm	Latched high TX Bias alarm, channel 2
	2	L-Tx2 Bias Low Alarm	Latched low TX Bias alarm, channel 2
	1	L-Tx2 Bias High Warning	Latched high TX Bias warning, channel 2



Byte	Bit	Name	Description
	0	L-Tx2 Bias Low Warning	Latched low TX Bias warning, channel 2
12	7	L-Tx3 Bias High Alarm	Latched high TX Bias alarm, channel 3
	6	L-Tx3 Bias Low Alarm	Latched low TX Bias alarm, channel 3
	5	L-Tx3 Bias High Warning	Latched high TX Bias warning, channel 3
	4	L-Tx3 Bias Low Warning	Latched low TX Bias warning, channel 3
	3	L-Tx4 Bias High Alarm	Latched high TX Bias alarm, channel 4
	2	L-Tx4 Bias Low Alarm	Latched low TX Bias alarm, channel 4
	1	L-Tx4 Bias High Warning	Latched high TX Bias warning, channel 4
	0	L-Tx4 Bias Low Warning	Latched low TX Bias warning, channel 4
	13	7	L-Tx1 Power High Alarm
6		L-Tx1 Power Low Alarm	Latched low TX power alarm, channel 1
5		L-Tx1 Power High Warning	Latched high TX power warning, channel 1
4		L-Tx1 Power Low Warning	Latched low TX power warning, channel 1
3		L-Tx2 Power High Alarm	Latched high TX power alarm, channel 2
2		L-Tx2 Power Low Alarm	Latched low TX power alarm, channel 2
1		L-Tx2 Power High Warning	Latched high TX power warning, channel 2
0		L-Tx2 Power Low Warning	Latched low TX power warning, channel 2
14	7	L-Tx3 Power High Alarm	Latched high TX power alarm, channel 3
	6	L-Tx3 Power Low Alarm	Latched low TX power alarm, channel 3
	5	L-Tx3 Power High Warning	Latched high TX power warning, channel 3
	4	L-Tx3 Power Low Warning	Latched low TX power warning, channel 3
	3	L-Tx4 Power High Alarm	Latched high TX power alarm, channel 4
	2	L-Tx4 Power Low Alarm	Latched low TX power alarm, channel 4
	1	L-Tx4 Power High Warning	Latched high TX power warning, channel 4
	0	L-Tx4 Power Low Warning	Latched low TX power warning, channel 4
15-21	All	Reserved	

Module Monitoring Values

Module Monitoring Value is intended to measure module temperature and supply voltage. The internally measured Module temperature is represented as a 16-bit signed 2's complement value in increments of 1/256 degrees Celsius as described below. This representation yields a total range of -128°C to +127°C. The operational values according to the module specification are considered valid between -10°C and +85°C. The module temperature accuracy is better than ±3 degrees Celsius over the specified operating temperature and voltage.

Sign	26	25	24	23	22	21	20	2-1	2-2	2-3	2-4	2-5	2-6	2-7	2-8
------	----	----	----	----	----	----	----	-----	-----	-----	-----	-----	-----	-----	-----

Temperature word bit weights representation

The internally measured Module supply voltage is represented as a 16-bit unsigned integer with the voltage defined as the full 16 bit value (0 – 65535) with LSB equal to 100 µVolt, yielding a total measurement range of 0 to +6.55 Volts. The accuracy of the voltage is than ±3% of the nominal value over specified operating temperature and voltage.



Byte	Bit	Name	Description
Module Monitoring Values			
22	All	Temperature MSB	Internally measured module temperature
23	All	Temperature LSB	
24-25	All	Reserved	
26	All	Supply Voltage MSB	Internally measured module supply voltage
27	All	Supply Voltage LSB	
28-33	All	Reserved	

Channel Monitoring Values

The Channel Monitors for RX Power and TX Bias are defined in the table below:

Byte	Bit	Name	Description
Description of Channel Monitor Values (Lower Memory Map)			
34	All	Rx1 power MSB	Internally measured RX input power, channel 1
35	All	Rx1 power LSB	
36	All	Rx2 power MSB	Internally measured RX input power, channel 2
37	All	Rx2 power LSB	
38	All	Rx3 power MSB	Internally measured RX input power, channel 3
39	All	Rx3 power LSB	
40	All	Rx4 power MSB	Internally measured RX input power, channel 4
41	All	Rx4 power LSB	
42	All	Tx1 Bias MSB	Internally measured TX bias, channel 1
43	All	Tx1 Bias LSB	
44	All	Tx2 Bias MSB	Internally measured TX bias, channel 2
45	All	Tx2 Bias LSB	
46	All	Tx3 Bias MSB	Internally measured TX bias, channel 3
47	All	Tx3 Bias LSB	
48	All	Tx4 Bias MSB	Internally measured TX bias, channel 4
49	All	Tx4 Bias LSB	
50	All	Tx1 power MSB	Internally measured TX output power, channel 1
51	All	Tx1 power LSB	
52	All	Tx2 power MSB	Internally measured TX output power, channel 2
53	All	Tx2 power LSB	
54	All	Tx3 power MSB	Internally measured TX output power, channel 3
55	All	Tx3 power LSB	
56	All	Tx4 power MSB	Internally measured TX output power, channel 4



Byte	Bit	Name	Description
57	All	Tx4 power LSB	
58	All	VCCTX_MONITOR_MSB	
59	All	VCCTX_MONITOR_LSB	
60	All	Vcc Rx MSB	Internally measured RX VCC
61	All	Vcc Rx LSB	
62	All	VCC1_MONITOR_MSB	
63	All	VCC1_MONITOR_LSB	
64	All	TEMP1_MONITOR_MSB	
65	All	TEMP1_MONITOR_LSB	
66-73	All	00h all bytes	Reserved Channel monitor

The description for the Laser Bias current and Receiver Power Monitors are detailed below.

Laser Bias Current:

Measured TX bias current is in mA and are represented as a 16-bit unsigned integer with the current defined as the full 16 bit value (0 – 65535) with LSB equal to 2 uA, yielding a total measurement range of 0 to 131 mA. Accuracy is vendor specific but must be better than ±10% of the manufacturer's nominal value over specified operating temperature and voltage.

Received Power:

Measured RX received optical power is in mW and can represent either average received power or OMA depending upon how bit 3 of byte 220 (upper memory page 00h) is set. Represented as a 16 bit unsigned integer with the power defined as the full 16 bit value (0 – 65535) with LSB equal to 0.1 uW, yielding a total measurement range of 0 to 6.5535mW (~-40 to +8.2 dBm). Absolute accuracy is dependent upon the exact optical wavelength. For the vendor specified wavelength, accuracy shall be better than ±3 dB over specified temperature and voltage. This accuracy shall be maintained for input power levels up to the lesser of maximum transmitted or maximum received optical power per the appropriate standard. It shall be maintained down to the minimum transmitted power minus cable plant loss (insertion loss or passive loss) per the appropriate standard. Absolute accuracy beyond this minimum required received input optical power range is vendor specific.

Control Bytes

There are 4 control bits to enable or disable each of the 4 transmitter channels. Disabling is done by setting any one of the 4 bits of byte 86 to '1'. Bits 0÷1 of byte 93 controls the LPM mode functionality of the module. The Control Bytes are described below:

Byte	Bit	Name	Description
Description of the Control Bytes.			
86	7-4	Reserved	
	3	Tx4_Disable	Read/write bit that allows software disable of transmitters
	2	Tx3_Disable	Read/write bit that allows software disable of transmitters
	1	Tx2_Disable	Read/write bit that allows software disable of transmitters
	0	Tx1_Disable	Read/write bit that allows software disable of transmitters
87-92	All	Reserved	All bits are ignored and read as '0's upon power up
93	2-7	Reserved	
	1	Power_set	Power set to low power mode. Default 0.
	0	Power_override	Override of LPM mode signal setting the power mode with software
94-99		Reserved	



Module and Channel Masks

The host can control each interrupt event from the QSFP module by masking the corresponding interrupt bits. When a mask bit is written as '1', an interrupt will not occur for this specific event. When the bit is unmasked ('0'), the QSFP will initiate an interrupt by asserting IntL to LOW when a specific event occurs. Using interrupt mask bits enable the host to use polling routine if desirable. The table below depicts the bits and the bytes to mask interrupt events.

Byte	Bit	Name	Description
Description of Module and channel Interrupt masking bits			
86	7-4	Reserved	
	3	Tx4_Disable	Read/write bit that allows software disable of transmitters
	2	Tx3_Disable	Read/write bit that allows software disable of transmitters
	1	Tx2_Disable	Read/write bit that allows software disable of transmitters
	0	Tx1_Disable	Read/write bit that allows software disable of transmitters
87-92	All	Reserved	All bits are ignored and read as '0's upon power up
93	2-7	Reserved	
	1	Power_set	Power set to low power mode. Default 0.
	0	Power_over-ride	Override of LPMode signal setting the power mode with software
94-99		Reserved	

Module and Channel Masks

The host can control each interrupt event from the QSFP module by masking the corresponding interrupt bits. When a mask bit is written as '1', an interrupt will not occur for this specific event. When the bit is unmasked ('0'), the QSFP will initiate an interrupt by asserting IntL to LOW when a specific event occurs. Using interrupt mask bits enable the host to use polling routine if desirable. The table below depicts the bits and the bytes to mask interrupt events.

Byte	Bit	Name	Description
Description of Module and channel Interrupt masking bits			
100	7-4	Reserved	
	3	M-Rx4 LOS	Masking bit for RX LOS indicator, channel 4
	2	M-Rx3 LOS	Masking bit for RX LOS indicator, channel 3
	1	M-Rx2 LOS	Masking bit for RX LOS indicator, channel 2
	0	M-Rx1 LOS	Masking bit for RX LOS indicator, channel 1
101	7-4	Reserved	
	3	M-Tx4 Fault	Masking bit for TX fault indicator, channel 4
	2	M-Tx3 Fault	Masking bit for TX fault indicator, channel 3
	1	M-Tx2 Fault	Masking bit for TX fault indicator, channel 2
	0	M-Tx1 Fault	Masking bit for TX fault indicator, channel 1
102	All	Reserved	
103	7	M-Temp High Alarm	Masking bit for high Temperature alarm
	6	M-Temp Low Alarm	Masking bit for low Temperature alarm



Byte	Bit	Name	Description
	5	M-Temp High Warning	Masking bit for high Temperature warning
	4	M-Temp Low Warning	Masking bit for low Temperature warning
	3-0	Reserved	
104	7	M-Vcc High Alarm	Masking bit for high Vcc alarm
	6	M- Vcc Low Alarm	Masking bit for low Vcc alarm
	5	M- Vcc High Warning	Masking bit for high Vcc warning
	4	M- Vcc Low Warning	Masking bit for low Vcc warning
	3-0	Reserved	
105-106	All	Reserved	

Password and Page Select

Bytes 119-126 are reserved for an optional password entry function. The Password entry by tesare write only and will be retained until power down, reset, or rewritten by host. This function may be used to control read/ write access to vendor specific page 02h. Additionally, module vendors may use this function to implement write protection of Serial ID and other QSFP+ read only information. Passwords may be supplied to and used by Host manufacturers to limit write access in the User EEPROM Page 02h. Password access shall not be required to access QSFP+ defined data in the lower memory page 00h or in upper pages 00h, 02h and 03h. Note that multiple module manufacturer passwords may be defined to allow selective access to read or write to various sections of memory as allowed above. Host manufacturer and module manufacturer passwords shall be distinguished by the high order bit (bit 7, byte 123). All host manufacturer passwords shall fall in the range of 00000000h to 7FFFFFFFh, and all module manufacturer passwords in the range of 80000000h to FFFFFFFFh. Host manufacturer passwords shall be initially set to 00001011h in new modules. Host manufacturer passwords may be changed by writing a new password in bytes 119-122 when the correct current Host manufacture password has been entered in 123-126, with the high order bit being ignored and forced to a value of 0 in the new password. The password entry field shall be set to 00000000hon power up and reset.

Data Address	Bit	Name of Field	Value	Description of field
107-118	All	Reserved	0000h Read/Write	
119-122	All	Password Change Entry Area (optional)	00000000h Read/Write	
123-126	All	Password Entry Area (optional)	00000000h Read/Write	
127	All	Page Select Byte	00h Read/Write	

Upper Memory Map Page 00h Description

Page 00h consists of the Serial ID and is used for read only identification information. The Serial ID is divided into the Base_ID Fields, Extended ID Fields and Vendor Specific ID Fields.The format of the Serial ID Memory Map is shown below.



Upper memory map page 00h general description of the QSFP module.

Address	Size(Bytes)	Name	Description of Base ID Field
Base_ID Fields			
128	1	Identifier	Identifier Type of serial transceiver
129	1	Ext. Identifier	Extended identifier of serial transceiver
130	1	connector	Code for connector type
131-138	8	Transceiver	Code for electronic compatibility or optical compatibility
139	1	Encoding	Code for serial encoding algorithm
140	1	BR,nominal	Nominal bit rate, units of 100 Mbits/s
141	1	Extended RateSelect Compliance	Tags for Extended RateSelect compliance
142	1	Length(SMF)	Link length supported for SMF fiber in km
143	1	Length(E-50um)	Link length supported for EBW 50/125 um fiber, units of 2 m
144	1	Length(50 um)	Link length supported for 50/125 um fiber, units of 1 m
145	1	Length(62.5 um)	Link length supported for 62.5/125 um fiber, units of 1 m
146	1	Length(Copper)	Link length supported for copper, units of 1 m
147	1	Device Tech	Device Technology
148-163	16	Vendor name	QSFP vendor name (ASCII)
164	1	Extended Transceiver	Extended Transceiver Codes for InfiniBand
165-167	3	Vendor OUI	QSFP vendor IEEE company ID
168-183	16	Vendor PN	Part number provided by QSFP vendor (ASCII)
184-185	2	Vendor rev	Revision level for part number provided by vendor (ASCII)
186-187	2	Wavelength	Nominal laser wavelength (wavelength=value/20 in nm)
188-189	2	Wavelength Tolerance	Guaranteed range of laser wavelength (+/- value) from Nominal wavelength. (wavelength Tol.=value/200 in nm)
190	1	Max Case Temp	Maximum Case Temperature in Degrees C
191	1	CC_BASE	Check code for Base ID Fields(addresses 128-190)
Extended ID Fields			
192-195	4	Options	Rate Select, TX Disable, TX Fault, LOS
196-211	16	Vendor SN	Serial number provided by vendor (ASCII)
212-219	8	Date code	Vendor's manufacturing date code
220	1	Diagnostic Monitoring Type	Indicates which type of diagnostic monitoring is implemented (if any) in the transceiver. Bit 1, 0 Reserved
221	1	Enhanced Options	Indicates which optional enhanced features are implemented in the transceiver.
222	1	Reserved	Reserved
223	1	CC_EXT	Check code for the Extended ID Fields(addresses 192-222)
Vendor Specific ID Fields			
224-255	32	Vendor Specific	Vendor Specific EEPROM



Byte	Bit	Name of Bit	Description
Identifier (Address 128)			
128	All	Identifier	0Dh=QSFP+
Extended Identifier (Address 129)			
129	7-6	Ext. Identifier	'11': Power Class 4 Module (3.5 W max. power consumption)
	5	Reserved	0
	4	NO CLEI code present in Page 02h	0
	3	NO CDR in TX	0
	2	NO CDR in RX	0
	1-0	Reserved	0
Module Connector Type (Address 130)			
130	All	Connector Type	07h = LC
Transceiver Definition (Address 131-138)			
131	All	Connection Data	02h = 40GBase-LR 4
132-138	All	Reserved	
Module Data Encoding (Address 139)			
139	All	Encoding	00h = unspecified (It is transparent for all givencodes (01h-05h) in the standard.
Module Extended Rate and Length (Addresses 140-146)			
140-141	All	Reserved	
142	All	SMF length support	0Ah (10km)
143-146	All	Reserved	
Device Technology (Address 147)			
147	7-4	Device Technology	04h = (DFB laser at 1310nm).
	3		0: No wavelength control, 1: Active wavelength control (=0)
	2		0: Uncooled transmitter device, 1: Cooled transmitter (=0)
	1		0: PIN detector, 1: APD detector (=0)
	0		0: Transmitter not tunable, 1: Transmitter tunable (=0)
16 Character Vendor Name (Address 148-163)			
148-163	All	Vendor Name	'FiberStamp' (there are 7 ASCII spaces padded on the right to get 16 characters.)
Extended Transceiver Codes (Address 164)			
164	7-4	Reserved	
	3	EDR Speed (20 Gb/s)	0
	2	QDR Speed (10 Gb/s)	1 (support QDR per lane)
	1	DDR Speed (5.0 Gb/s)	1 (support DDR per lane)



Byte	Bit	Name of Bit	Description
	0	SDR Speed (2.5 Gbps)	1 (support SDR per lane)
Vendor Information (Address 165-185)			
165-167	All	Vendor OUI	Organization Unique Identifier
168-183	All	Vendor PN	40GE/OTU3 QSFP+ LR4 1310nm 10km Optical Transceiver Module
184-185	All	Vendor Rev	Product Revision number
Wavelength and Wavelength Tolerance (Address 186-189)			
186-189		Reserved	
Maximum Case Temperature (Address 190)			
190	All		Standard Temp = 700C = 46h.
Check Code Base (Address 191)			
191	All	CC_Base	Low 8 bits of the sum of the content of all page00 byte from 128 to 190 inclusive.
Module Options (Address 192-195)			
192	All		Reserved
193	7-1		Reserved
	0	Rx Amplitude Programming	'1' - implemented
194	7-4	Options	Reserved
	3	Rx_Squelch Disable implemented	'1' - implemented
	2	Rx_Output Disable capable	'1' - implemented
	1	Tx Squelch Disable implemented	'0' – Not implemented
	0	Tx Squelch implemented:	'0' – Not implemented
195	7	Memory page 02 provided	'1' - implemented
	6	Memory page 01 provided	'0' – Not implemented
	5	RATE_SELECT is implemented	'0' – Not implemented
	4	TX_DISABLE is implemented	'1' - implemented
	3	TX_FAULT signal implemented	'1' - implemented
	2	Tx Squelch implemented	'0' – Not implemented
	1	TX Loss of Signal implemented	'0' – Not implemented
h	0		Reserved
Vendor SN (Address 196-211)			
196-211	All	Vendor SN	yy ww cccc (yy – Year, ww – Work week , cccc – Counter)
Module Date Code (Address 212-219)			
212-213	All	Year	Two low order ASCII digits of year (2000=00).
214-215	All	Month	Two ASCII digits of month (January=01) through (December=12).



Byte	Bit	Name of Bit	Description
216-217	All	Day	ASCII Code of Day of Month (01-31)
218-219	All	Lot Code	Vendor Specific Lot number
Diagnostic Monitoring Type (Address 220)			
220	7-4	Reserved	
	3	Rx Monitoring is Average Power ('1') or OMA ('0')	'1'
	2-0	Reserved	
Check Code Extended (Address 223)			
223	All	CC_EXT	Low 8 bits of the sum of the content of all page00 byte from 192 to 222 inclusive.
Vendor Specific EEPROM (Address 224-255)			
224-255	All		Vendor Specific Code

Upper Memory Map Page Description

Upper Memory Map Page	Description																								
01h	Not implemented for user.																								
02h	Page 02 is optionally provided as user writable EEPROM. The host system may read or write this memory for any purpose																								
03h	<table border="1"> <thead> <tr> <th>Byte Address</th> <th>Description</th> <th>Type</th> </tr> </thead> <tbody> <tr> <td>128-175</td> <td>Module Thresholds(48 Bytes)</td> <td>Read-Only</td> </tr> <tr> <td>176-223</td> <td>Channel Thresholds(48 Bytes)</td> <td>Read-Only</td> </tr> <tr> <td>224-225</td> <td>Reserved(2 Bytes)</td> <td>Read-Only</td> </tr> <tr> <td>226-239</td> <td>Vendor Specific Channel Controls(14 Bytes)</td> <td>Read/Write</td> </tr> <tr> <td>240-241</td> <td>Optional Channel Controls(2 Bytes)</td> <td>Read/Write</td> </tr> <tr> <td>242-253</td> <td>Channel Monitor Masks(12 Bytes)</td> <td>Read/Write</td> </tr> <tr> <td>254-255</td> <td>Reserved(2 Bytes)</td> <td>Read/Write</td> </tr> </tbody> </table>	Byte Address	Description	Type	128-175	Module Thresholds(48 Bytes)	Read-Only	176-223	Channel Thresholds(48 Bytes)	Read-Only	224-225	Reserved(2 Bytes)	Read-Only	226-239	Vendor Specific Channel Controls(14 Bytes)	Read/Write	240-241	Optional Channel Controls(2 Bytes)	Read/Write	242-253	Channel Monitor Masks(12 Bytes)	Read/Write	254-255	Reserved(2 Bytes)	Read/Write
	Byte Address	Description	Type																						
	128-175	Module Thresholds(48 Bytes)	Read-Only																						
	176-223	Channel Thresholds(48 Bytes)	Read-Only																						
	224-225	Reserved(2 Bytes)	Read-Only																						
	226-239	Vendor Specific Channel Controls(14 Bytes)	Read/Write																						
	240-241	Optional Channel Controls(2 Bytes)	Read/Write																						
	242-253	Channel Monitor Masks(12 Bytes)	Read/Write																						
254-255	Reserved(2 Bytes)	Read/Write																							

Output Amplitude Control

The output voltage levels of the 4 RX lanes are set using a global register that controls all fourlanes simultaneously. The register definition and default value are given in the table below.

Output Control per Lane			
Byte	Size(Bytes)	Name	Default Value
238	3-0	RX1-RX4 output amplitude	'2'h



Rx Squelch and Output Disable Control

This enables to control RX_SQ and RX_DIS operation of the transceiver. The default value is '0' upon power up. Therefore Squelch is operational when power up. When '1' is written for specific channel, then this channel Squelch functionality will be disabled. When writing '1' in RX_Output_Disable, the output of this specific channel will be disabled.

Squelch and Output Disable Controls			
Byte	Bits	Name	Description
240	7	Rx4_SQ_Disable	Rx Squelch Disable, channel 4
	6	Rx3_SQ_Disable	Rx Squelch Disable, channel 3
	5	Rx2_SQ_Disable	Rx Squelch Disable, channel 2
	4	Rx1_SQ_Disable	Rx Squelch Disable, channel 1
241	7	Rx4_Output_Disable	Rx Output Disable, channel 4
	6	Rx3_Output_Disable	Rx Output Disable, channel 3
	5	Rx2_Output_Disable	Rx Output Disable, channel 2
	4	Rx1_Output_Disable	Rx Output Disable, channel 1
	3-0	Reserved	

Channel Monitor Masks

The masking Bits for the Channel Monitor Functions are defined below. When writing '1' in a specific bit location, then this specific channel interrupt is disabled upon reaching specific threshold parameter. The bits can mask High or Low Warning signals or Alarm signals for each individual receiving and transmitting channels.

Channel Monitor Masks			
Byte	Bits	Name	Description
242	7	M-Rx1 Power High Alarm	Masking bit for high RX Power alarm, channel 1
	6	M-Rx1 Power Low Alarm	Masking bit for low RX Power alarm, channel 1
	5	M-Rx1 Power High warning	Masking bit for high RX Power warning, channel 1
	4	M-Rx1 Power Low warning	Masking bit for low RX Power warning, channel 1
	3	M-Rx2 Power High Alarm	Masking bit for high RX Power alarm, channel 2
	2	M-Rx2 Power Low Alarm	Masking bit for low RX Power alarm, channel 2
	1	M-Rx2 Power High warning	Masking bit for high RX Power warning, channel 2
	0	M-Rx2 Power Low warning	Masking bit for low RX Power warning, channel 2
243	7	M-Rx3 Power High Alarm	Masking bit for high RX Power alarm, channel 3
	6	M-Rx3 Power Low Alarm	Masking bit for low RX Power alarm, channel 3
	5	M-Rx3 Power High warning	Masking bit for high RX Power warning, channel 3
	4	M-Rx3 Power Low warning	Masking bit for low RX Power warning, channel 3
	3	M-Rx4 Power High Alarm	Masking bit for high RX Power alarm, channel 4
	2	M-Rx4 Power Low Alarm	Masking bit for low RX Power alarm, channel 4
	1	M-Rx4 Power High warning	Masking bit for high RX Power warning, channel 4
	0	M-Rx4 Power Low warning	Masking bit for low RX Power warning, channel 4



Channel Monitor Masks			
244	7	M-Tx1 Bias High Alarm	Masking bit for high TX Bias alarm, channel 1
	6	M-Tx1 Bias Low Alarm	Masking bit for low TX Bias alarm, channel 1
	5	M-Tx1 Bias High warning	Masking bit for high TX Bias warning, channel 1
	4	M-Tx1 Bias Low warning	Masking bit for low TX Bias warning, channel 1
	3	M-Tx2 Bias High Alarm	Masking bit for high TX Bias alarm, channel 2
	2	M-Tx2 Bias Low Alarm	Masking bit for low TX Bias alarm, channel 2
	1	M-Tx2 Bias High warning	Masking bit for high TX Bias warning, channel 2
	0	M-Tx2 Bias Low warning	Masking bit for low TX Bias warning, channel 2
245	7	M-Tx3 Bias High Alarm	Masking bit for high TX Bias alarm, channel 3
	6	M-Tx3 Bias Low Alarm	Masking bit for low TX Bias alarm, channel 3
	5	M-Tx3 Bias High warning	Masking bit for high TX Bias warning, channel 3
	4	M-Tx3 Bias Low warning	Masking bit for low TX Bias warning, channel 3
	3	M-Tx4 Bias High Alarm	Masking bit for high TX Bias alarm, channel 4
	2	M-Tx4 Bias Low Alarm	Masking bit for low TX Bias alarm, channel 4
	1	M-Tx4 Bias High warning	Masking bit for high TX Bias warning, channel 4
	0	M-Tx4 Bias Low warning	Masking bit for low TX Bias warning, channel 4
246	7	M-Tx1 Power High Alarm	Masking bit for high TX Power alarm, channel 1
	6	M-Tx1 Power Low Alarm	Masking bit for low TX Power alarm, channel 1
	5	M-Tx1 Power High warning	Masking bit for high TX Power warning, channel 1
	4	M-Tx1 Power Low warning	Masking bit for low TX Power warning, channel 1
	3	M-Tx2 Power High Alarm	Masking bit for high TX Power alarm, channel 2
	2	M-Tx2 Power Low Alarm	Masking bit for low TX Power alarm, channel 2
	1	M-Tx2 Power High warning	Masking bit for high TX Power warning, channel 2
	0	M-Tx2 Power Low warning	Masking bit for low TX Power warning, channel 2
247	7	M-Tx3 Power High Alarm	Masking bit for high TX Power alarm, channel 3
	6	M-Tx3 Power Low Alarm	Masking bit for low TX Power alarm, channel 3
	5	M-Tx3 Power High warning	Masking bit for high TX Power warning, channel 3
	4	M-Tx3 Power Low warning	Masking bit for low TX Power warning, channel 3
	3	M-Tx4 Power High Alarm	Masking bit for high TX Power alarm, channel 4
	2	M-Tx4 Power Low Alarm	Masking bit for low TX Power alarm, channel 4
	1	M-Tx4 Power High warning	Masking bit for high TX Power warning, channel 4
	0	M-Tx4 Power Low warning	Masking bit for low TX Power warning, channel 4
248-255	All	Reserved	



Mechanical Dimensions

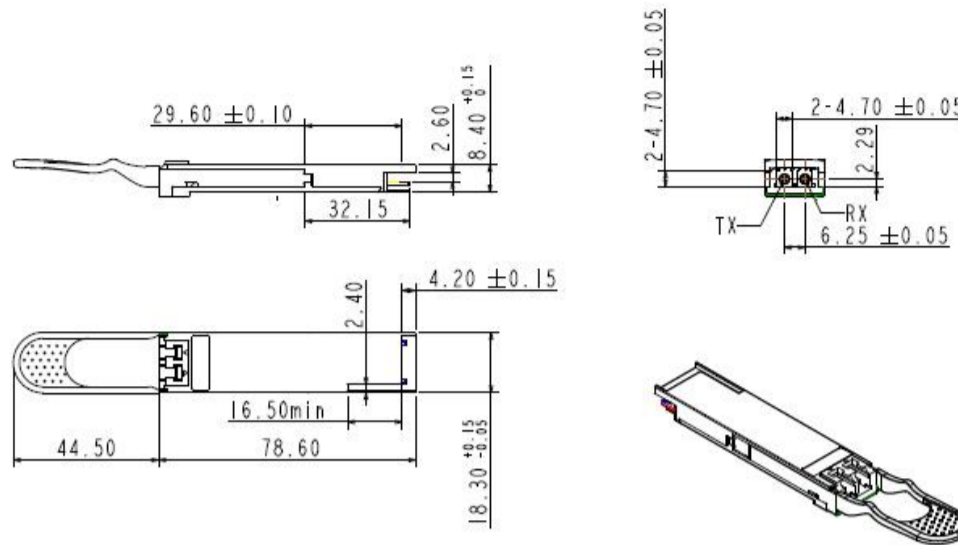

Ordering information

Part Number	Product Description
FST-40G-LR4	40GE/OTU3 QSFP+ LR4 1310nm 10km Optical Transceiver Module

ESD

This QSFP LR4 is specified as ESD threshold 1KV for high speed data pins and 2KV for all others electrical input pins, tested per MIL-STD-883, Method 3015.4 /JESD22-A114-A (HBM). However, normal ESD precautions are still required during the handling of this module. This transceiver is shipped in ESD protective packaging. It should be removed from the packaging and handled only in an ESD protected environment.

Regulatory Compliance

Feature	Standard
Laser Safety	IEC 60825-1:2014 (Third Edition)
Environmental protection	2011/65/EU
CE EMC	EN55032: 2015 EN55024: 2010+A1: 2015 EN61000-3-2:2014 EN61000-3-3:2013
FCC	FCC Part 15, Subpart B; ANSI C63.4-2014
Product Safety	EN/UL 60950-1, 2nd Edition, 2014-10-14

Laser Safety

This is a Class 1 Laser Product according to IEC 60825-1:2007. This product complies with 21 CFR 1040.10 and 1040.11 except for deviations pursuant to Laser Notice No. 50, dated (June 24, 2007).

CAUTION:

Use of controls or adjustment or performance of procedures other than those specified herein may result in hazardous radiation exposure

Important Notice

Performance figures, data and any illustrative material provided in this data sheet are typical and must be specifically confirmed in writing by FiberStamp before they become applicable to any particular order or contract. In accordance with the FiberStamp policy of continuous improvement specifications may change without notice.

The publication of information in this data sheet does not imply freedom from patent or other protective rights of FiberStamp or others. Further details are available from any FiberStamp sales representative.

