

3G-SDI Video CWDM SFP 40km Single-Transmitter Optical Modules

FSST-3G-xxC40

Features

- HD-SDI SFP Transmitter available
- SD-SDI SFP Transmitter available
- 3G-SDI SFP Transmitter available
- SMPTE 297-2006 Compatible
- Metal enclosure for Lower EMI
- 18 CWDM DFB laser
- Supports video pathological patterns for SD-SDI, HD-SDI and 3G-SDI
- Non-MSA Pinout
- Digital Diagnostic functions available through the I2C interface
- Compatible with RoHS
- +3.3V single power supply
- Operating case temperature:
- Standard : 0 to +70°C

Applications

- SMPTE 297-2006 Compatible Electrical-to-Optical Interfaces
- HDTV/SDTV Service Interfaces

Description

The video series transceivers are high performance, cost effective modules for duplex video transmission application over single mode fiber. The Transmitter is designed to transmit data rates from 50Mbps to 2.97Gbps and is specifically designed for robust performance in the presence of SDI pathological patterns for SMPTE 259M, SMPTE 344M, SMPTE 292M and SMPTE 424M serial rates. The module is fully compliant with SMPTE 297M-2006. The transmitter is consists of two sections: a DFB laser transmitter and MCU control unit. All modules satisfy class I laser safety requirements. The transceivers are compatible with SFP Multi-Source Agreement (MSA) and SFF-8472. For further information, please refer to SFP MSA.

Absolute Maximum Ratings

Parameter	Symbol	Min	Max	Unit
Supply Voltage	Vcc	-0.5	4.5	V
Storage Temperature	Ts	-40	+85	°C
Operating Humidity	-	5	85	%



Recommended Operating Conditions

Parameter	Symbol	Min	Typical	Max	Unit
Operating Case Temperature	Tc	0		+70	°C
Power Supply Voltage	Vcc	3.13	3.3	3.47	V
Power Supply Current	Icc			350	mA
Data Rate			3		Gbps

Optical and Electrical Characteristics

Parameter	Symbol	Min	Typical	Max	Unit	Notes
Transmitter						
Center Wavelength	λ_c	$\lambda_c-6.5$	λ_c	$\lambda_c+6.5$	nm	
Spectral Width (-20dB)	σ			1	nm	
Side Mode Suppression Ratio	SMSR	30			dB	
Average Output Power	Pout	-2	0	+3	dBm	1
Extinction Ratio	ER	5			dB	
Rise/Fall Time (20%~80%)	SD-SDI	tr/ff		1500	ps	2
	HD-SDI			270		
	3G-SDI			135		
Total Output Jitter	PRBS and colour bar	SD-SDI		70	ps	
		HD-SDI		50		
		3G-SDI		70		
	pathological	SD-SDI		200		
		HD-SDI		115		
		3G-SDI		120		
Data Input Swing Differential	VIN	400		1800	mV	3
Input Differential Impedance	ZIN	90	100	110	Ω	
TX Disable	Disable		2.0		Vcc	V
	Enable		0		0.8	V
TX Fault	Fault		2.0		Vcc	V
	Normal		0		0.8	V

Notes:

1. The optical power is launched into SMF.
2. Rise and fall times, 20% to 80%, are measured following a fourth-order Bessel-Thompson filter with a bandwidth of 0.75 x clock frequency corresponding to the serial data rate
3. PECL input, internally AC-coupled and terminated.
4. Internally AC-coupled.



Timing and Electrical

Parameter	Symbol	Min	Typical	Max	Unit
Tx Disable Negate Time	t_on			1	ms
Tx Disable Assert Time	t_off			10	µs
Time To Initialize, including Reset of Tx Fault	t_init			300	ms
Tx Fault Assert Time	t_fault			100	µs
Tx Disable To Reset	t_reset	10			µs
Serial ID Clock Rate	f_serial_clock			280	KHz
MOD_DEF (0:2)-High	VH	2		Vcc	V
MOD_DEF (0:2)-Low	VL			0.8	V

Diagnostics Specification

Parameter	Range	Unit	Accuracy	Calibration
Temperature	0 to +70	°C	±3°C	Internal / External
Voltage	3.0 to 3.6	V	±3%	Internal / External
Bias Current	0 to 100	mA	±10%	Internal / External
TX Power	-2 to 3	dBm	±3dB	Internal / External

I2C Bus Interface

The I2C bus interface uses the 2-wire serial CMOS E2PROM protocol. The serial interface meets the following specifications:

- 1.Support a maximum clock rate of 280Khz.
2. Input/Output levels comply with LVCMOS/LVTTL or compatible logics.

Low: 0 – 0.8 V

High: 2.0 – 3.3 V

Undefined: 0.8 – 2.0 V

Pin Definitions (Non-MSA Pinout)

Top of Board

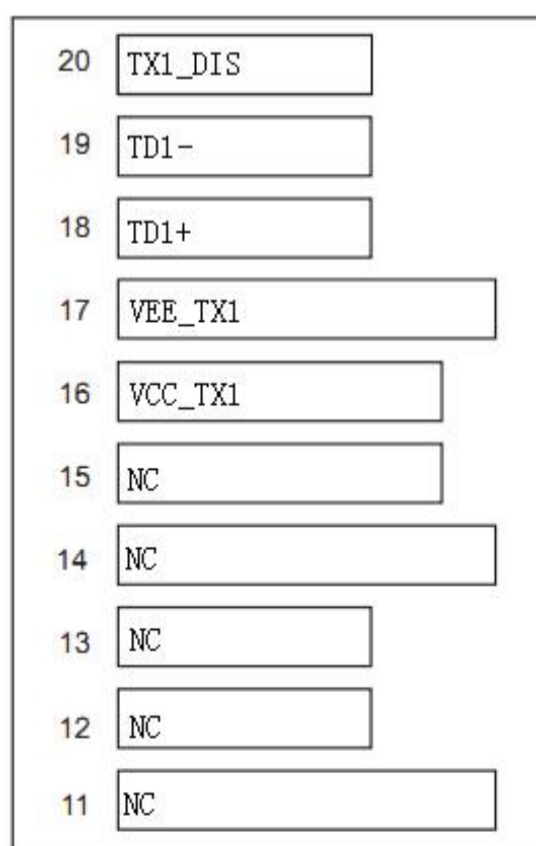

Bottom of Board

(as viewed through top of board)

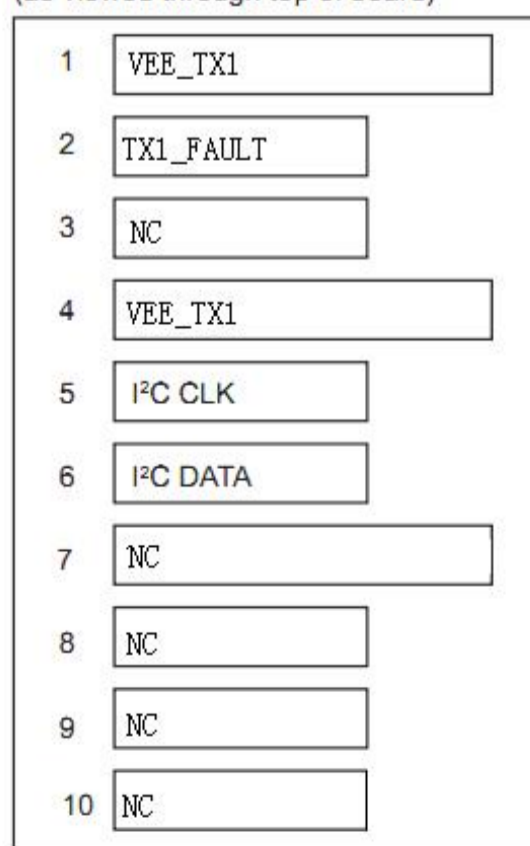

Pin Descriptions

Pin	Signal Name	Description	Plug Seq.	Notes
1	VEE_TX1	Transmitter 1 Ground	1	
2	TX1_FAULT	Transmitter 1 Fault Indication	3	Note 1
3	NC	Not Connected		
4	VEE_TX1	Transmitter 1 Ground	1	
5	I2C CLK	SCL Serial Clock Signal	3	Note 3
6	I2C DATA	SDA Serial Data Signal	3	Note 3
7	NC	Not Connected		
8	NC	Not Connected		
9	NC	I Not Connected		
10	NC	Not Connected		
11	NC	Not Connected		
12	NC	Not Connected		
13	NC	Not Connected		
14	NC	Not Connected		
15	NC	Not Connected		
16	VCC_TX1	Transmitter Power 1 Supply	2	
17	VEE_TX1	Transmitter 1 Ground	1	
18	TD1+	Transmit 1 Data In	3	Note 4
19	TD1-	Inv. Transmit 1 Data In	3	Note 4
20	TX1_DIS	Transmitter 1 Disable	3	Note 2

Notes:

Plug Seq.: Pin engagement sequence during hot plugging.

1) TX Fault is an open collector output, which should be pulled up with a 4.7k~10kΩ resistor on the host board to a voltage between 2.0V and Vcc+0.3V. Logic 0 indicates normal operation; Logic 1 indicates a laser fault of some kind. In the low state, the output will be pulled to less than 0.8V.

2) TX Disable is an input that is used to shut down the transmitter optical output. It is pulled up within the module with a 4.7k~10kΩ resistor. Its states are:

- Low (0 to 0.8V): Transmitter on
- (>0.8V, < 2.0V): Undefined
- High (2.0 to 3.465V): Transmitter Disabled
- Open: Transmitter Disabled

3) They should be pulled up with a 4.7k~10kΩ resistor on the host board. The pull-up voltage shall be VCC_TX1 or VCC_TX2.

I2C CLK is the clock line of two wire serial interface for serial ID

I2C DATA is the data line of two wire serial interface for serial ID

4) TD1/2-/+: These are the differential transmitter inputs. They are internally AC-coupled, differential lines with 100Ω differential termination inside the module.



CWDM Wavelength (0~70°C)

Band	Suffix	Wavelength (nm)
O-band (Original)	A	1270
	B	1290
	C	1310
	D	1330
	E	1350
E-band (Extended)	F	1370
	G	1390
	H	1410
	I	1430
	J	1450
S-band (Short Wavelength)	K	1470
	L	1490
	M	1510
	N	1530
C-band (Conventional)	O	1550
L-band (Long Wavelength)	P	1570
	Q	1590
	R	1610

Mechanical Dimensions

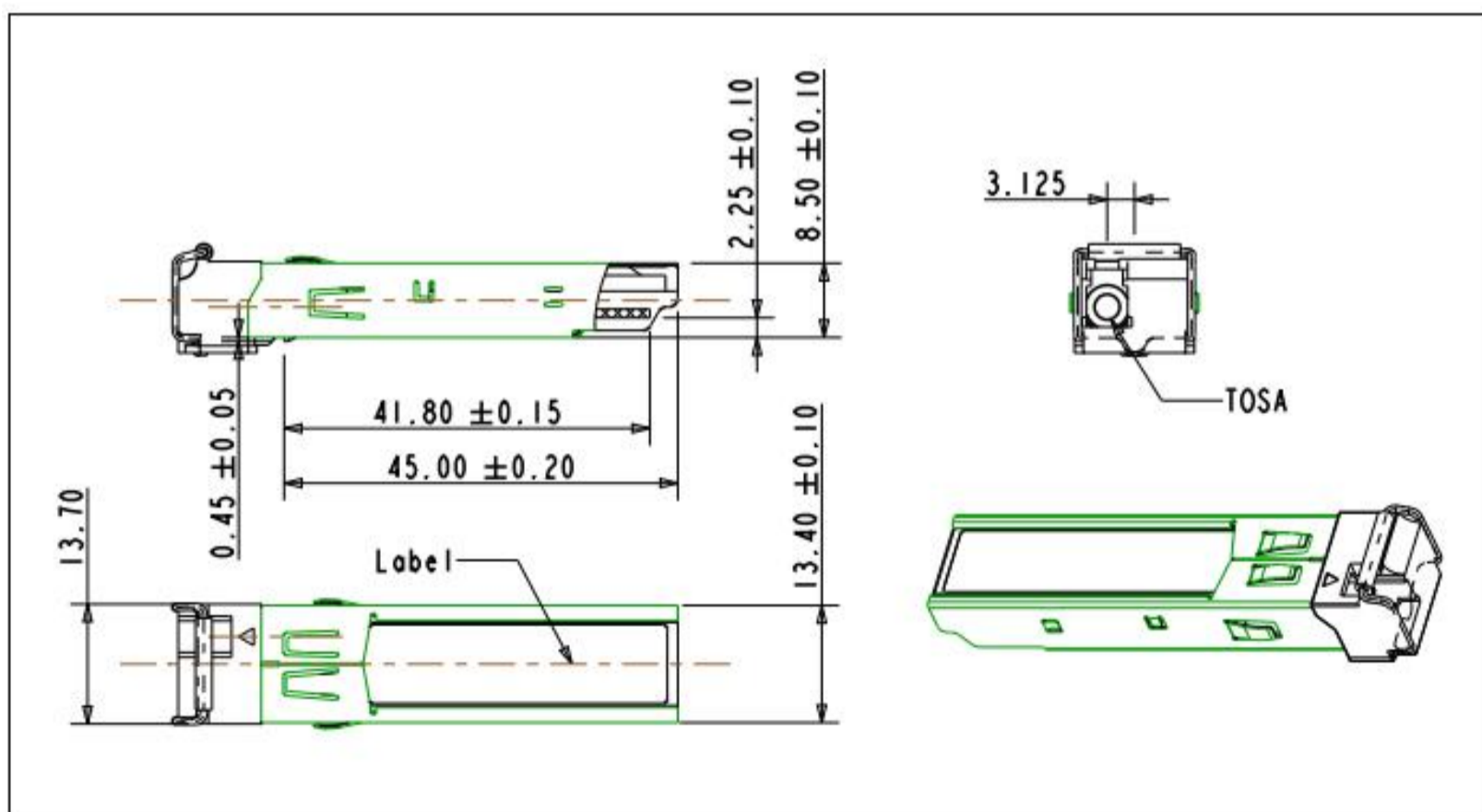

Ordering information

Part Number	Product Description
FSST-3G-27C40	3G-SDI Video CWDM SFP 40km Single-Transmitter Optical Module, 1270nm
FSST-3G-29C40	3G-SDI Video CWDM SFP 40km Single-Transmitter Optical Module, 1290nm
FSST-3G-31C40	3G-SDI Video CWDM SFP 40km Single-Transmitter Optical Module, 1310nm
FSST-3G-33C40	3G-SDI Video CWDM SFP 40km Single-Transmitter Optical Module, 1330nm
FSST-3G-35C40	3G-SDI Video CWDM SFP 40km Single-Transmitter Optical Module, 1350nm
FSST-3G-37C40	3G-SDI Video CWDM SFP 40km Single-Transmitter Optical Module, 1370nm
FSST-3G-39C40	3G-SDI Video CWDM SFP 40km Single-Transmitter Optical Module, 1390nm
FSST-3G-41C40	3G-SDI Video CWDM SFP 40km Single-Transmitter Optical Module, 1410nm
FSST-3G-43C40	3G-SDI Video CWDM SFP 40km Single-Transmitter Optical Module, 1430nm
FSST-3G-45C40	3G-SDI Video CWDM SFP 40km Single-Transmitter Optical Module, 1450nm
FSST-3G-47C40	3G-SDI Video CWDM SFP 40km Single-Transmitter Optical Module, 1470nm
FSST-3G-49C40	3G-SDI Video CWDM SFP 40km Single-Transmitter Optical Module, 1490nm
FSST-3G-51C40	3G-SDI Video CWDM SFP 40km Single-Transmitter Optical Module, 1510nm
FSST-3G-53C40	3G-SDI Video CWDM SFP 40km Single-Transmitter Optical Module, 1530nm
FSST-3G-55C40	3G-SDI Video CWDM SFP 40km Single-Transmitter Optical Module, 1550nm
FSST-3G-57C40	3G-SDI Video CWDM SFP 40km Single-Transmitter Optical Module, 1570nm
FSST-3G-59C40	3G-SDI Video CWDM SFP 40km Single-Transmitter Optical Module, 1590nm
FSST-3G-61C40	3G-SDI Video CWDM SFP 40km Single-Transmitter Optical Module, 1610nm

Important Notice

Performance figures, data and any illustrative material provided in this data sheet are typical and must be specifically confirmed in writing by FiberStamp before they become applicable to any particular order or contract. In accordance with the FiberStamp policy of continuous improvement specifications may change without notice.

The publication of information in this data sheet does not imply freedom from patent or other protective rights of FiberStamp or others. Further details are available from any FiberStamp sales representative.

