

3G-SDI CWDM SFP 1270nm-1610nm 80km Optical Transceiver Module

FBA-V3GCxxK80CM

Features

- HD-SDI SFP Transceiver available
- SD-SDI SFP Transceiver available
- 3G-SDI SFP Transceiver available
- SMPTE 297-2006 Compatible.
- Metal enclosure for Lower EMI
- 18 CWDM DFB laser and APD photo-detector
- Supports video pathological patterns for SD-SDI, HD-SDI and 3G-SDI
- Compliant with SFP MSA and SFF-8472 with duplex LC receptacle
- Digital Diagnostic functions available through the I2C interface
- Compatible with RoHS
- +3.3V single power supply
- Operating case temperature:
- Standard : 0 to +70°C



Applications

- SMPTE 297-2006 Compatible Electrical-to-Optical Interfaces.
- HDTV/SDTV Service Interfaces.

Description

The video series transceivers are high performance, cost effective modules for duplex video transmission application over single mode fiber.

The transceiver is designed to transmit/receive data rates from 50Mbps to 2.97Gbps and is specifically designed for robust performance in the presence of SDI pathological patterns for SMPTE 259M, SMPTE 344M, SMPTE 292M and SMPTE 424M serial rates. The module is fully compliant with SMPTE 297M-2006.

The transceiver consists of three sections: a DFB laser transmitter, an APD photodiode integrated with a trans-impedance preamplifier (TIA) and MCU control unit. All modules satisfy class I laser safety requirements.

The transceivers are compatible with SFP Multi-Source Agreement (MSA) and SFF-8472. For further information, please refer to SFP MSA.

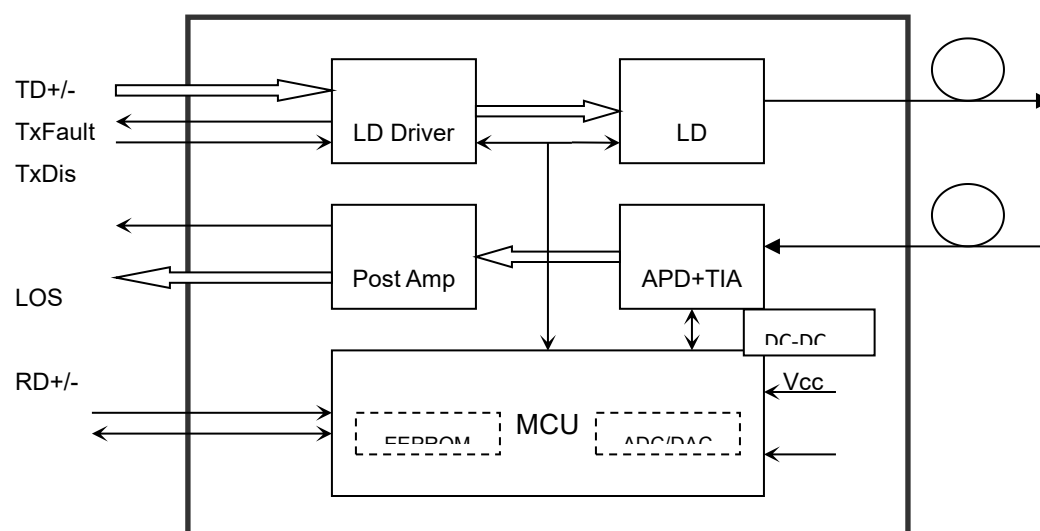

Absolute Maximum Ratings

Parameter	Symbol	Min	Max	Unit
Supply Voltage	V _{cc}	-0.5	4.5	V
Storage Temperature	T _s	-40	+85	°C
Operating Humidity	-	5	85	%

Recommended Operating Conditions

Parameter	Symbol	Min	Typical	Max	Unit
Operating Case Temperature	Standard	0		+70	°C
					°C
Power Supply Voltage	V _{cc}	3.13	3.3	3.47	V
Power Supply Current	I _{cc}			400	mA
Data Rate			3		Gbps

Optical and Electrical Characteristics

Parameter	Symbol	Min	Typical	Max	Unit	Notes
Transmitter						
Centre Wavelength	λ_c	$\lambda_c-6.5$	λ_c	$\lambda_c+6.5$	nm	6
Spectral Width (-20dB)	σ			1	nm	
Side Mode Suppression Ratio	SMSR	30			dB	
Average Output Power	P _{out}	-2	0	+4	dBm	1
Extinction Ratio	ER	5	7		dB	
Rise/Fall Time (20%~80%)	SD-SDI			1500	ps	2
	HD-SDI			270		
	3G-SDI			135		
Total Output Jitter	PRBS and colour bar	SD-SDI		70	ps	
		HD-SDI		50		
		3G-SDI		70		
	pathological	SD-SDI		200		
		HD-SDI		115		
		3G-SDI		120		
Data Input Swing Differential	V _{IN}	400		1800	mV	3
Input Differential Impedance	Z _{IN}	90	100	110	Ω	
TX Disable	Disable		2.0	V _{cc}	V	
	Enable		0	0.8	V	
TX Fault	Fault		2.0	V _{cc}	V	
	Normal		0	0.8	V	
Receiver						

Parameter	Symbol	Min	Typical	Max	Unit	Notes
Centre Wavelength	λ_c	1260		1610	nm	
Receiver Sensitivity (PRBS)	SD-SDI			-31	dBm	
	HD-SDI			-29	dBm	
	3G-SDI			-28	dBm	
Receiver Sensitivity (Pathological)	SD-SDI			-31	dBm	
	HD-SDI			-29	dBm	5
	3G-SDI			-28	dBm	
Receiver Overload		-10			dBm	4
LOS De-Assert	LOSD			-20	dBm	
LOS Assert	LOSA	-30			dBm	
LOS Hysteresis		1		4	dB	
Data Output Swing Differential	Vout	650	800	1000	mV	3
LOS	High	2.0		Vcc	V	
	Low			0.8	V	

Notes:

1. The optical power is launched into SMF.
2. Rise and fall times, 20% to 80%, are measured following a fourth-order Bessel-Thompson filter with a bandwidth of 0.75 x clock frequency corresponding to the serial data rate
3. PECL input, internally AC-coupled and terminated.
4. Internally AC-coupled.
5. The sensitivity and overload specification refers to the input power levels for BER = 1E-12 against both PRBS and pathological patterns at SMPTE 259M, SMPTE 292M and SMPTE 424M rates.
6. pls refer to the table of CWDM Wavelength about λ .

Timing and Electrical

Parameter	Symbol	Min	Typical	Max	Unit
Tx Disable Negate Time	t_on			1	ms
Tx Disable Assert Time	t_off			10	μ s
Time To Initialize, including Reset of Tx Fault	t_init			300	ms
Tx Fault Assert Time	t_fault			100	μ s
Tx Disable To Reset	t_reset	10			μ s
LOS Assert Time	t_loss_on			100	μ s
LOS De-assert Time	t_loss_off			100	μ s
Serial ID Clock Rate	f_serial_clock			400	KHz
MOD_DEF (0:2)-High	VH	2		Vcc	V
MOD_DEF (0:2)-Low	VL			0.8	V



Diagnostics Specification

Parameter	Range	Unit	Accuracy	Calibration
Temperature	0 to +70	°C	±3°C	Internal / External
Voltage	3.0 to 3.6	V	±3%	Internal / External
Bias Current	0 to 100	mA	±10%	Internal / External
TX Power	-2 to +3	dBm	±3dB	Internal / External
RX Power	-20 to -6	dBm	±3dB	Internal / External

I2C Bus Interface

The I2C bus interface uses the 2-wire serial CMOS E2PROM protocol. The serial interface meets the following specifications:

- Support a maximum clock rate of 280Khz.
- Input/Output levels comply with LVCMOS/LVTTL or compatible logics.

Low: 0 – 0.8 V

High: 2.0 – 3.3 V

Undefined: 0.8 – 2.0 V

Pin Definitions

Pin Diagram

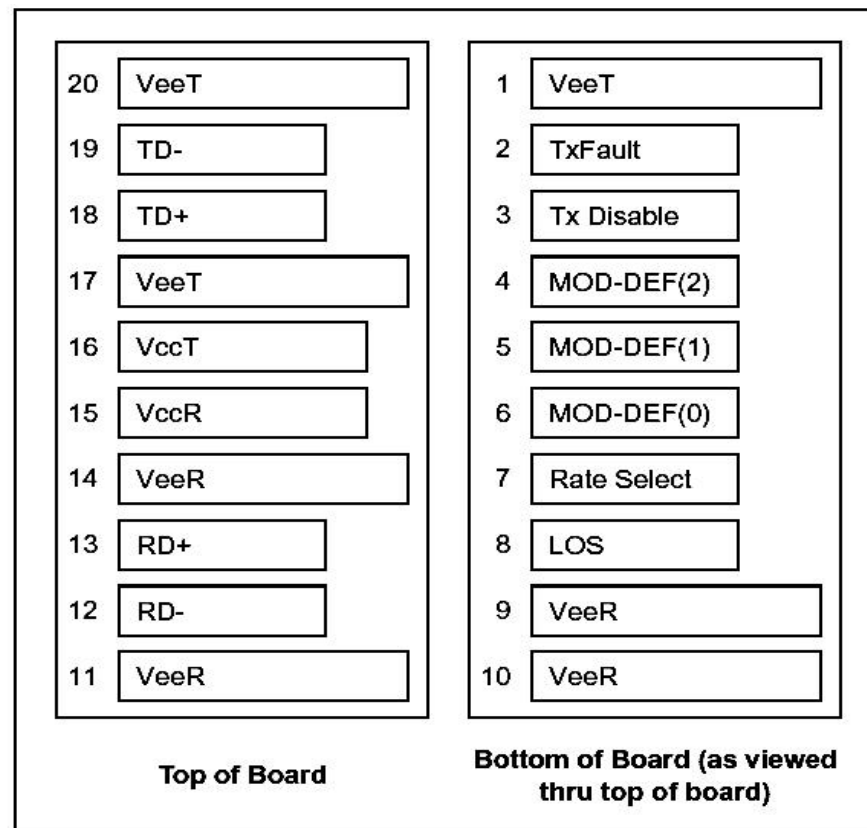

Pin Descriptions

Pin	Signal Name	Description	Plug Seq.	Notes
1	VEET	Transmitter Ground	1	
2	TX FAULT	Transmitter Fault Indication	3	Note 1
3	TX DISABLE	Transmitter Disable	3	Note 2
4	MOD_DEF(2)	SDA Serial Data Signal	3	Note 3
5	MOD_DEF(1)	SCL Serial Clock Signal	3	Note 3
6	MOD_DEF(0)	TTL Low	3	Note 3
7	Rate Select	Not Connected	3	

Pin	Signal Name	Description	Plug Seq.	Notes
8	LOS	Loss of Signal	3	Note 4
9	VEER	Receiver ground	1	
10	VEER	Receiver ground	1	
11	VEER	Receiver ground	1	
12	RD-	Inv. Received Data Out	3	Note 5
13	RD+	Received Data Out	3	Note 5
14	VEER	Receiver ground	1	
15	VCCR	Receiver Power Supply	2	
16	VCCT	Transmitter Power Supply	2	
17	VEET	Transmitter Ground	1	
18	TD+	Transmit Data In	3	Note 6
19	TD-	Inv. Transmit Data In	3	Note 6
20	VEET	Transmitter Ground	1	

Notes:

Plug Seq.: Pin engagement sequence during hot plugging.

1. TX Fault is an open collector output, which should be pulled up with a 4.7k~10kΩ resistor on the host board to a voltage between 2.0V and Vcc+0.3V. Logic 0 indicates normal operation; Logic 1 indicates a laser fault of some kind. In the low state, the output will be pulled to less than 0.8V.

2. TX Disable is an input that is used to shut down the transmitter optical output. It is pulled up within the module with a 4.7k~10kΩ resistor. Its states are:

- Low (0 to 0.8V): Transmitter on
- (>0.8V, < 2.0V): Undefined
- High (2.0 to 3.465V): Transmitter Disabled
- Open: Transmitter Disabled

3. Mod-Def 0,1,2. These are the module definition pins. They should be pulled up with a 4.7k~10kΩ resistor on the host board. The pull-up voltage shall be VccT or VccR.

Mod-Def 0 is grounded by the module to indicate that the module is present

Mod-Def 1 is the clock line of two wire serial interface for serial ID

Mod-Def 2 is the data line of two wire serial interface for serial ID

4. LOS is an open collector output, which should be pulled up with a 4.7k~10kΩ resistor. Pull up voltage between 2.0V and Vcc+0.3V. Logic 1 indicates loss of signal; Logic 0 indicates normal operation. In the low state, the output will be pulled to less than 0.8V.

5. RD-/+: These are the differential receiver outputs. They are internally AC-coupled 100 differential lines which should be terminated with 100Ω (differential) at the user SERDES.

6. TD-/+: These are the differential transmitter inputs. They are internally AC-coupled, differential lines with 100Ω differential termination inside the module.

CWDM Wavelength (0~70°C)

Band	Suffix	Wavelength (nm)
O-band Original	A	1270
	B	1290

Band	Suffix	Wavelength (nm)
	C	1310
	D	1330
	E	1350
E-band Extended	F	1370
	G	1390
	H	1410
	I	1430
	J	1450
S-band Short Wavelength	K	1470
	L	1490
	M	1510
	N	1530
C-band Conventional	O	1550
L-band Long Wavelength	P	1570
	Q	1590
	R	1610

Mechanical Dimensions

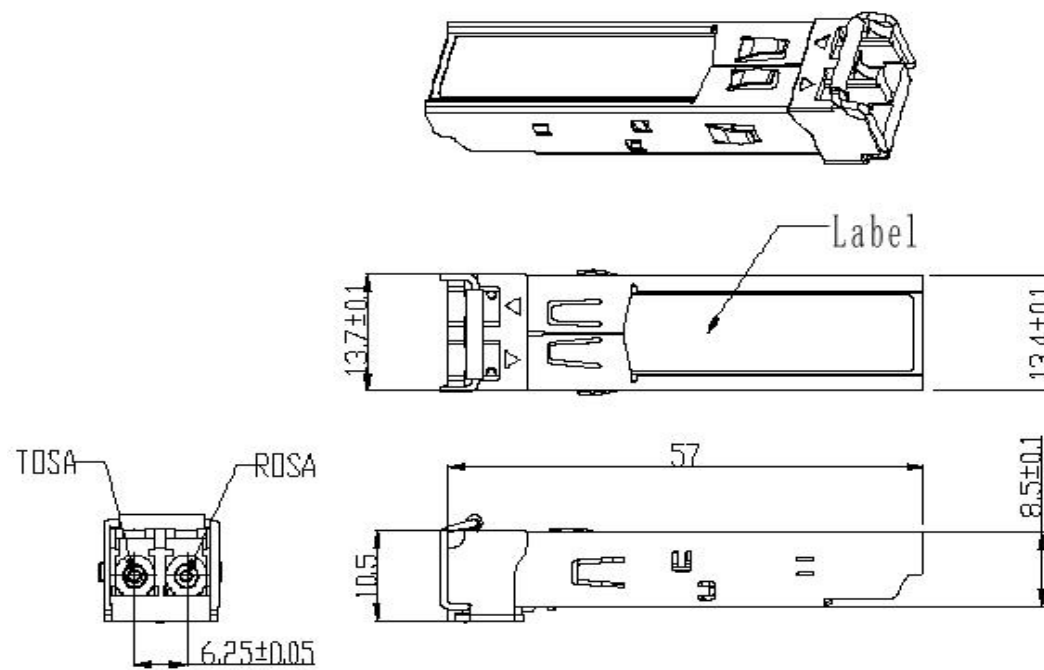

Ordering information

Part Number	Product Description
FBA-V3GCxxK80CM	CWDM, 3Gbps, 80km 0°C ~ +70°C, With Digital Diagnostic Monitoring

Important Notice

Performance figures, data and any illustrative material provided in this data sheet are typical and must be specifically confirmed in writing by GIGALIGHT before they become applicable to any particular order or contract. In accordance with the GIGALIGHT policy of continuous improvement specifications may change without notice.

The publication of information in this data sheet does not imply freedom from patent or other protective rights of GIGALIGHT or others. Further details are available from any GIGALIGHT sales representative.