

3Gbps Video SFP Optical Transmitter, 2km Reach

FJA-V3G3131K02CN

Features

- HD-SDI SFP Transmitter available
- SD-SDI SFP Transmitter available
- 3G-SDI SFP Transmitter available
- SMPTE 297-2006 Compatible.
- Metal enclosure for Lower EMI
- 1310nm FP laser , 2KM Reach
- Supports video pathological patterns for SD-SDI, HD-SDI and 3G-SDI
- Digital Diagnostic functions available through the I2C interface
- Compatible with RoHS
- +3.3V single power supply
- Operating case temperature:
- Standard : 0 to +70°C

Applications

- SMPTE 297-2006 Compatible Electrical-to-Optical Interfaces.
- HDTV/SDTV Service Interfaces.

Description

The video series transceivers are high performance, cost effective modules for duplex video transmission application over single mode fiber.

The Transmitter is designed to transmit data rates from 50Mbps to 2.97Gbps and is specifically designed for robust performance in the presence of SDI pathological patterns for SMPTE 259M, SMPTE 344M, SMPTE 292M and SMPTE 424M serial rates. The module is fully compliant with SMPTE 297M-2006.

The transmitter is a dual channel optical transmitter module ,one channel consists of two sections: a FP laser transmitter and MCU control unit. All modules satisfy class I laser safety requirements.

Absolute Maximum Ratings

Parameter	Symbol	Min	Max	Unit
Supply Voltage	Vcc	-0.5	4.5	V
Storage Temperature	Ts	-40	+85	°C
Operating Humidity	-	5	85	%

Recommended Operating Conditions

Parameter	Symbol	Min	Typical	Max	Unit
Operating Case Temperature	Tc	0		+70	°C
					°C
Power Supply Voltage	Vcc	3.13	3.3	3.47	V
Power Supply Current	Icc			500	mA
Data Rate			3		Gbps

Optical and Electrical Characteristics

Parameter	Symbol	Min	Typical	Max	Unit	Notes	
Transmitter							
Centre Wavelength	λ_c	1260	1310	1360	nm		
Spectral Width (-20dB)	σ			1	nm		
Average Output Power	Pout	-7	-3	-1	dBm	1	
Extinction Ratio	ER	5			dB		
Rise/Fall Time (20%~80%)	SD-SDI	tr/ff			1500	ps	2
	HD-SDI				270		
	3G-SDI				135		
Total Output Jitter	PRBS and colour bar	SD-SDI		70	200	ps	
		HD-SDI		50	135		
		3G-SDI		70	100		
	pathological	SD-SDI		200	300		
		HD-SDI		115			
		3G-SDI		120			
Data Input Swing Differential	VIN	400		1800	mV	3	
Input Differential Impedance	ZIN	90	100	110	Ω		
TX Disable	Disable		2.0		Vcc	V	
	Enable		0		0.8	V	
TX Fault	Fault		2.0		Vcc	V	
	Normal		0		0.8	V	

Notes:

1. The optical power is launched into SMF.
2. Rise and fall times, 20% to 80%, are measured following a fourth-order Bessel-Thompson filter with a bandwidth of 0.75 x clock frequency corresponding to the serial data rate
3. PECL input, internally AC-coupled and terminated.
4. Internally AC-coupled.

Timing and Electrical

Parameter	Symbol	Min	Typical	Max	Unit
Tx Disable Negate Time	t_on			1	ms
Tx Disable Assert Time	t_off			10	μ s
Time To Initialize, including Reset of Tx Fault	t_init			300	ms
Tx Fault Assert Time	t_fault			100	μ s
Tx Disable To Reset	t_reset	10			μ s
Serial ID Clock Rate	f_serial_clock			280	KHz
MOD_DEF (0:2)-High	VH	2		Vcc	V
MOD_DEF (0:2)-Low	VL			0.8	V



Diagnostics Specification

Parameter	Range	Unit	Accuracy	Calibration
Temperature	0 to +70	°C	±3°C	Internal / External
Voltage	3.0 to 3.6	V	±3%	Internal / External
Bias Current	0 to 100	mA	±10%	Internal / External
TX Power	-7 to -1	dBm	±3dB	Internal / External

I2C Bus Interface

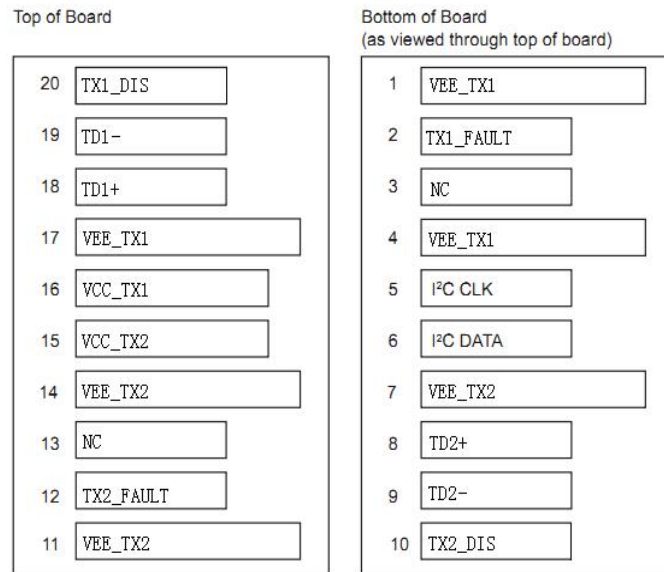

The I2C bus interface uses the 2-wire serial CMOS E2PROM protocol. The serial interface meets the following specifications:

- 1. Support a maximum clock rate of 280Khz.
- 2. Input/Output levels comply with LVCMOS/LVTTL or compatible logics.

Low: 0 – 0.8 V

High: 2.0 – 3.3 V

Undefined: 0.8 – 2.0 V

Pin Definitions (Non-MSA)

Pin Diagram

Pin Descriptions

Pin	Signal Name	Description	Plug Seq.	Notes
1	VEE_TX1	Transmitter 1 Ground	1	
2	TX1_FAULT	Transmitter 1 Fault Indication	3	Note 1
3	NC	Not Connected	3	
4	VEE_TX1	Transmitter 1 Ground	3	
5	I2C CLK	SCL Serial Clock Signal	3	Note 3
6	I2C DATA	SDA Serial Data Signal	3	Note 3
7	VEE_TX2	Transmitter 2 Ground	3	
8	TD2+	Transmit 2 Data In	3	Note 4
9	TD2-	Inv. Transmit 2 Data In	1	Note 4
10	TX2_DIS	Transmitter 2 Disable	1	Note 2
11	VEE_TX2	Transmitter 2 Ground	1	
12	TX2_FAULT	Transmitter 2 Fault Indication	3	Note 1
13	NC	Not Connected	3	

Pin	Signal Name	Description	Plug Seq.	Notes
14	VEE_TX2	Transmitter 2 Ground	1	
15	VCC_TX2	Transmitter Power 2 Supply	2	
16	VCC_TX1	Transmitter Power 1 Supply	2	
17	VEE_TX1	Transmitter 1 Ground	1	
18	TD1+	Transmit 1 Data In	3	Note 4
19	TD1-	Inv. Transmit 1 Data In	3	Note 4
20	TX1_DIS	Transmitter 1 Disable	1	Note 2

Notes:

Plug Seq.: Pin engagement sequence during hot plugging.

1) TX Fault is an open collector output, which should be pulled up with a 4.7k~10kΩ resistor on the host board to a voltage between 2.0V and Vcc+0.3V. Logic 0 indicates normal operation; Logic 1 indicates a laser fault of some kind. In the low state, the output will be pulled to less than 0.8V.

2) TX Disable is an input that is used to shut down the transmitter optical output. It is pulled up within the module with a 4.7k~10kΩ resistor. Its states are:

- Low (0 to 0.8V): Transmitter on
- (>0.8V, < 2.0V): Undefined
- High (2.0 to 3.465V): Transmitter Disabled
- Open: Transmitter Disabled

3) They should be pulled up with a 4.7k~10kΩ resistor on the host board. The pull-up voltage shall be VCC_TX1 or VCC_TX2.

I2C CLK is the clock line of two wire serial interface for serial ID

I2C DATA is the data line of two wire serial interface for serial ID

4) TD1/2-/+: These are the differential transmitter inputs. They are internally AC-coupled, differential lines with 100Ω differential termination inside the module.

Mechanical Dimensions

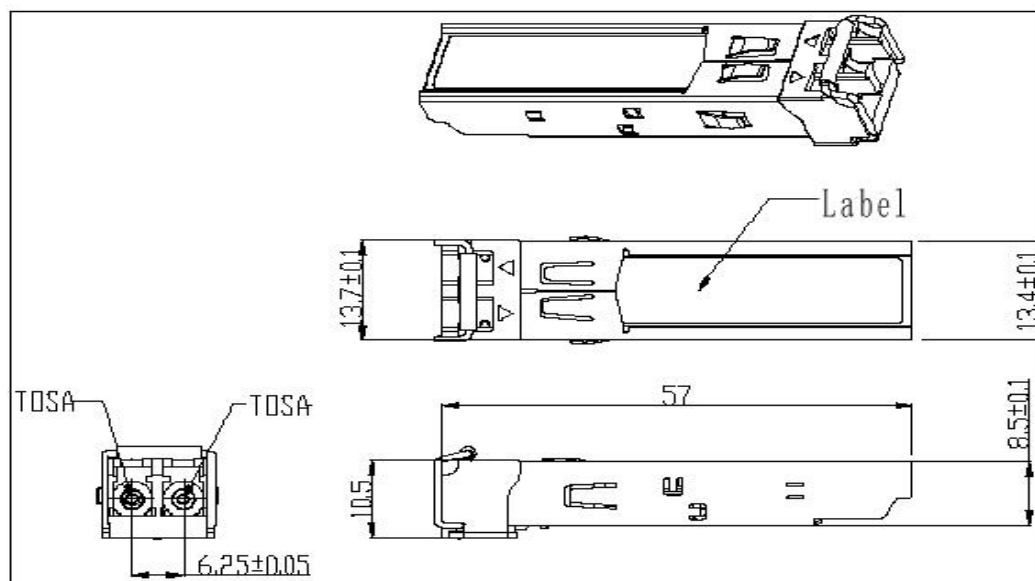

Ordering information

Part Number	Product Description
FJA-V3G3131K02CN	1310nm, 3Gbps, 2km, 0°C ~ +70°C, With Digital Diagnostic Monitoring, non-MSA Pinout

Important Notice

Performance figures, data and any illustrative material provided in this data sheet are typical and must be specifically confirmed in writing by FIBERSTAMP before they become applicable to any particular order or contract. In accordance with the FIBERSTAMP policy of continuous improvement specifications may change without notice.

The publication of information in this data sheet does not imply freedom from patent or other protective rights of FIBERSTAMP or others. Further details are available from any FIBERSTAMP sales representative.