

25Gbps 850nm SFP28 SR Optical Transceiver

FBC-D2585M30T

Features

- Hot-pluggable SFP28 form factor
- Supports 24.33Gbps and 25.78125Gbps data rate
- Maximum link length of 300m on OM4 MMF with FEC
- 850nm VCSEL laser and PIN photo-detector
- Internal CDR on both Transmitter and Receiver channel
- Duplex LC receptacle
- Single 3.3V power supply
- Power dissipation < 1W
- Digital diagnostics functions are available via the I2C interface
- RoHS-6 compliant 
- Case temperature range: -40°C to 85°C



Applications

- 5G eCPRI SFP28 SR
- 25GBASE-SR SFP28 25G Ethernet

Description

The FIBERSTAMP Technologies FBC-D2585M30T is a single-Channel, Pluggable, Fiber-Optic SFP28 for 24.33 Gigabit 5G eCPRI SR and 25GBASE-SR SFP28 25G Ethernet Applications. It is a high performance module for short-range data communication and interconnect applications which operate at 24.33 Gbps/25.78125Gbps up to 300m on OM4 fiber. This module is designed to operate over multimode fiber systems using a nominal wavelength of 850nm. The electrical interface uses a 20 contact edge type connector. The optical interface uses duplex LC receptacle. This module incorporates FIBERSTAMP Technologies proven circuit and VCSEL technology to provide reliable long life, high performance, and consistent service.

Block Diagram

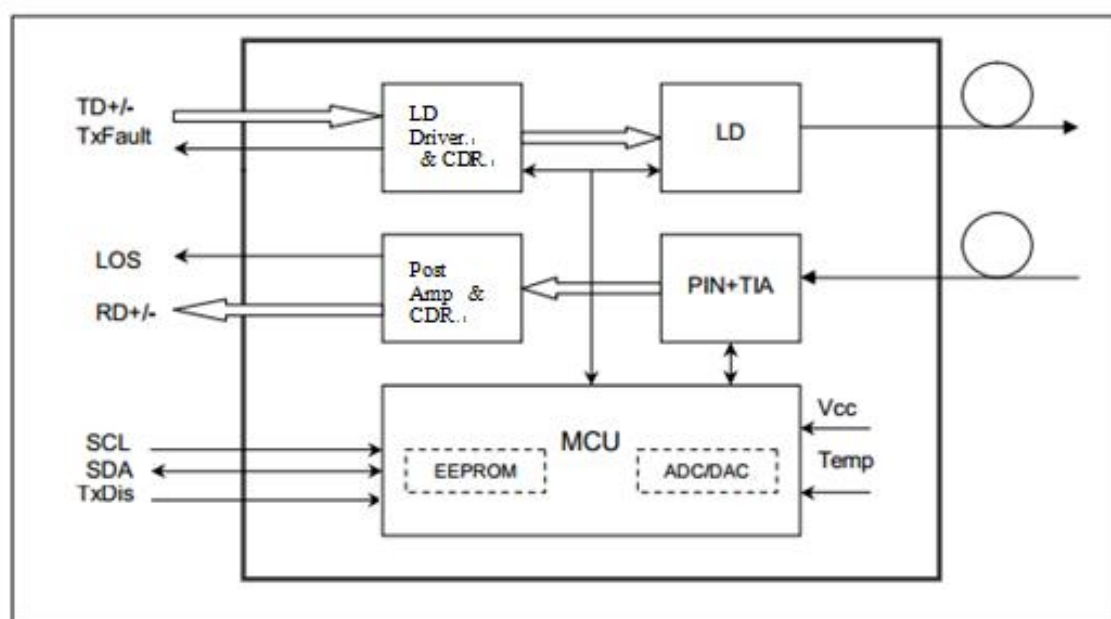

Absolute Maximum Ratings

Table 1 - Absolute Maximum Ratings

Parameter	Symbol	Min	Max	Unit
Supply Voltage	Vcc	0	3.6	V
Storage Temperature	Ts	-40	+85	°C
Operating Humidity	-	5	85	%

Recommended Operating Conditions

Table 2 - Recommended Operating Conditions

Parameter	Symbol	Min	Typical	Max	Unit
Operating Case Temperature	Tc	-40		85	°C
Power Supply Voltage	Vcc	3.13	3.3	3.47	V
Power Supply Current	Icc			300	mA
Fiber Length on 50/125µm high-bandwidth (OM3) MMF with FEC				200	m
Fiber Length on 50/125µm high-bandwidth (OM4) MMF with FEC				300	m

Optical and Electrical Characteristics

Table 3 - Optical and Electrical Characteristics

Parameter	Symbol	Min	Typical	Max	Unit	Notes
Transmitter						
Data rate	BR		24.33	25.78125	Gbps	
Centre Wavelength	λ_c	840	850	860	nm	
Spectral Width (-20dB)	σ			0.6	nm	
Average Output Power	Pavg	-8.4		3.4	dBm	
Optical Power OMA	POMA	-6.4		3	dBm	
Extinction Ratio	ER	2			dB	
Differential data input swing	VIN,PP	40		1000	mV	
Input Differential Impedance	ZIN	90	100	110	Ω	
TX Disable	Disable		2.0	Vcc	V	
	Enable		0	0.8	V	
TX Fault	Fault		2.0	Vcc	V	
	Normal		0	0.8	V	
Receiver						
Data rate	BR		24.33	25.78125	Gbps	
Centre Wavelength	λ_c	840	850	860	nm	
Stressed Sensitivity (OMA)		-	-	-5.2	dBm	
Receiver Power (OMA)				3	dBm	
LOS De-Assert	LOSD			-13	dBm	



Parameter	Symbol	Min	Typical	Max	Unit	Notes
LOS Assert	LOSA	-30			dBm	
LOS Hysteresis		0.5			dB	
Differential data output swing	Vout,PP	300		850	mV	
LOS	High	2.0		Vcc	V	
	Low			0.8	V	

Notes: Receive Sensitivity measured with a prbs31 pattern @25.78125Gb/s, BER 1E-12;

Timing and Electrical

Table 4 - Timing and Electrical

Parameter	Symbol	Min.	Max.	Unit	Conditions
Tx_Disable assert time	t_off		100	µs	Rising edge of Tx_Disable to fall of output signal below 10% of nominal
Tx_Disable negate time	t_on		2	ms	Falling edge of Tx_Disable to rise of output signal above 90% of nominal. This only applies in normal operation, not during start up or fault recovery.
Time to initialize 2-wire interface	t_2w_start_up		300	ms	From power on or hot plug after the supply meeting Table 8.
Time to initialize	t_start_up		300	ms	From power supplies meeting Table 8 or hot plug or Tx disable negated during power up, or Tx_Fault recovery, until non-cooled power level I part (or non-cooled power level II part already enabled at power level II for Tx_Fault recovery) is fully operational.
Time to initialize cooled module and time to power up a cooled module to Power Level II	t_start_up_cooled		90	s	From power supplies meeting Table 8 or hot plug, or Tx disable negated during power up or Tx_Fault recovery, until cooled power level I part (or cooled power level II part during fault recovery) is fully operational. Also, from stop bit low-to-high SDA transition enabling Power Level II until cooled module is fully operational
Time to Power Up to Level II	t_power_level2		300	ms	From stop bit low-to-high SDA transition enabling power level II until non-cooled module is fully operational
Time to Power Down from Level II	t_power_down		300	ms	From stop bit low-to-high SDA transition disabling power level II until module is within power level I requirements
Tx_Fault assert	Tx_Fault_on		1	ms	From occurrence of fault to assertion of Tx_Fault
Tx_Fault assert for cooled module	Tx_Fault_on_cooled		50	ms	From occurrence of fault to assertion of Tx_Fault
Tx_Fault Reset	t_reset	10		µs	Time Tx_Disable must be held high to reset Tx_Fault
RS0, RS1 rate select timing for FC	t_RS0_FC, t_RS1_FC		500	µs	From assertion till stable output
RS0, RS1 rate select timing non FC	t_RS0, t_RS1		24	ms	From assertion till stable output
Rx_LOS assert delay	t_los_on		100	µs	From occurrence of loss of signal to assertion of Rx_LOS
Rx_LOS negate delay	t_los_off		100	µs	From occurrence of presence of signal to negation of Rx_LOS



Diagnostics

Table 5 – Diagnostics Specification

Parameter	Range	Unit	Accuracy	Calibration
Temperature	-40 to +85	°C	±3°C	Internal / External
Voltage	3.0 to 3.6	V	±3%	Internal / External
Bias Current	0 to 20	mA	±10%	Internal / External
TX Power	-8 to 3	dBm	±3dB	Internal / External
RX Power	-14 to 0	dBm	±3dB	Internal / External

Digital Diagnostic Memory Map

PIN	Logic	Symbol	Name / Description	Note
1		VeeT	Module Transmitter Ground	1
2	LVTTL-O	TX_Fault	Module Transmitter Fault	2
3	LVTTL-I	TX_Dis	Transmitter Disable; Turns off transmitter laser output	
4	LVTTL-I/O	SDA	2-Wire Serial Interface Data Line	2
5	LVTTL-I	SCL	2-Wire Serial Interface Clock	2
6		MOD_ABS	Module Definition, Grounded in the module	
7	LVTTL-I	RS0	Receiver Rate Select	
8	LVTTL-O	RX_LOS	Receiver Loss of Signal Indication Active LOW	
9	LVTTL-I	RS1	Transmitter Rate Select (not used)	
10		VeeR	Module Receiver Ground	1
11		VeeR	Module Receiver Ground	1
12	CML-O	RD-	Receiver Inverted Data Output	
13	CML-O	RD+	Receiver Data Output	
14		VeeR	Module Receiver Ground	1
15		VccR	Module Receiver 3.3 V Supply	
16		VccT	Module Receiver 3.3 V Supply	
17		VeeT	Module Transmitter Ground	1
18	CML-I	TD+	Transmitter Non-Inverted Data Input	
19	CML-I	TD-	Transmitter Inverted Data Input	
20		VeeT	Module Transmitter Ground	1

Notes:

1. Module ground pins GND are isolated from the module case.
2. Shall be pulled up with 4.7K-10Kohms to a voltage between 3.15V and 3.45V on the host board



Recommended Interface Circuit

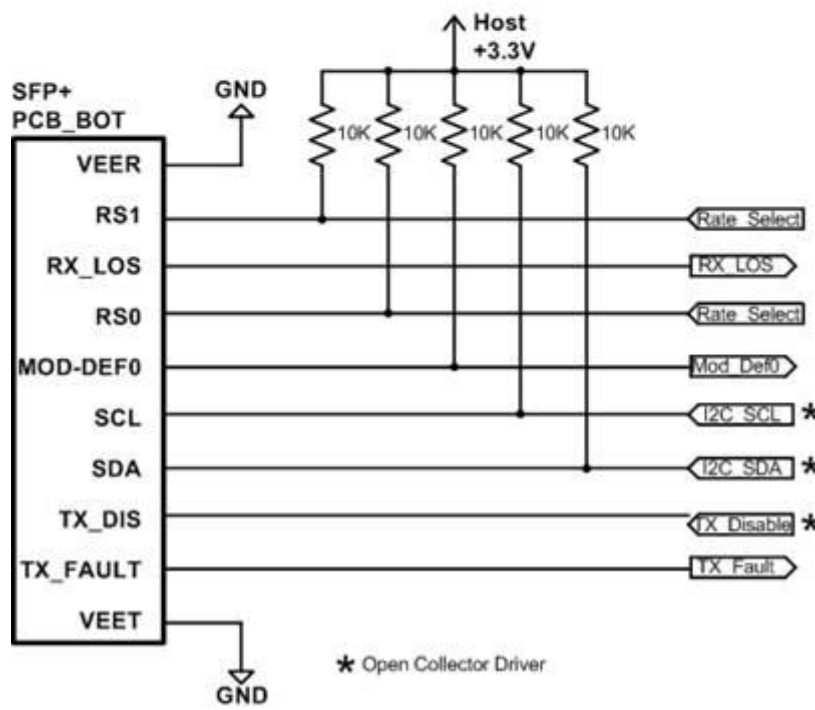
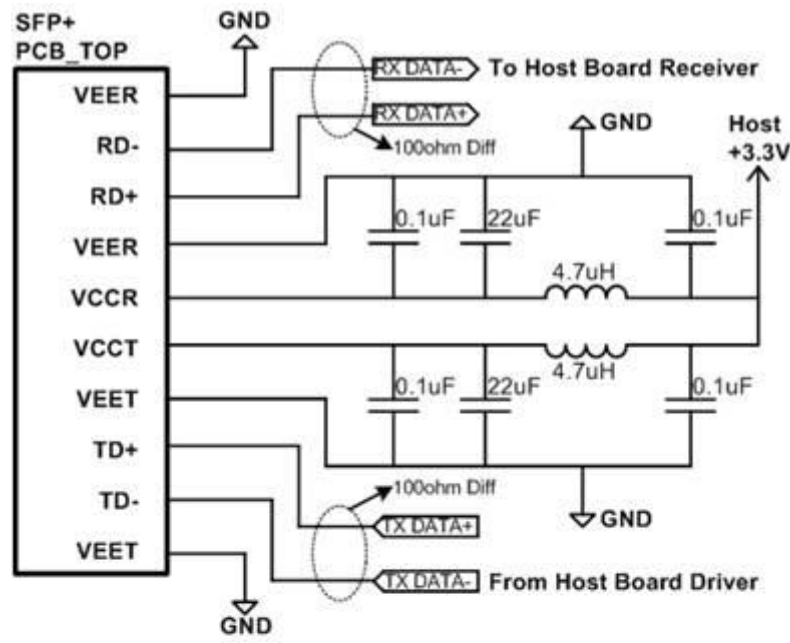

Mechanical Dimensions

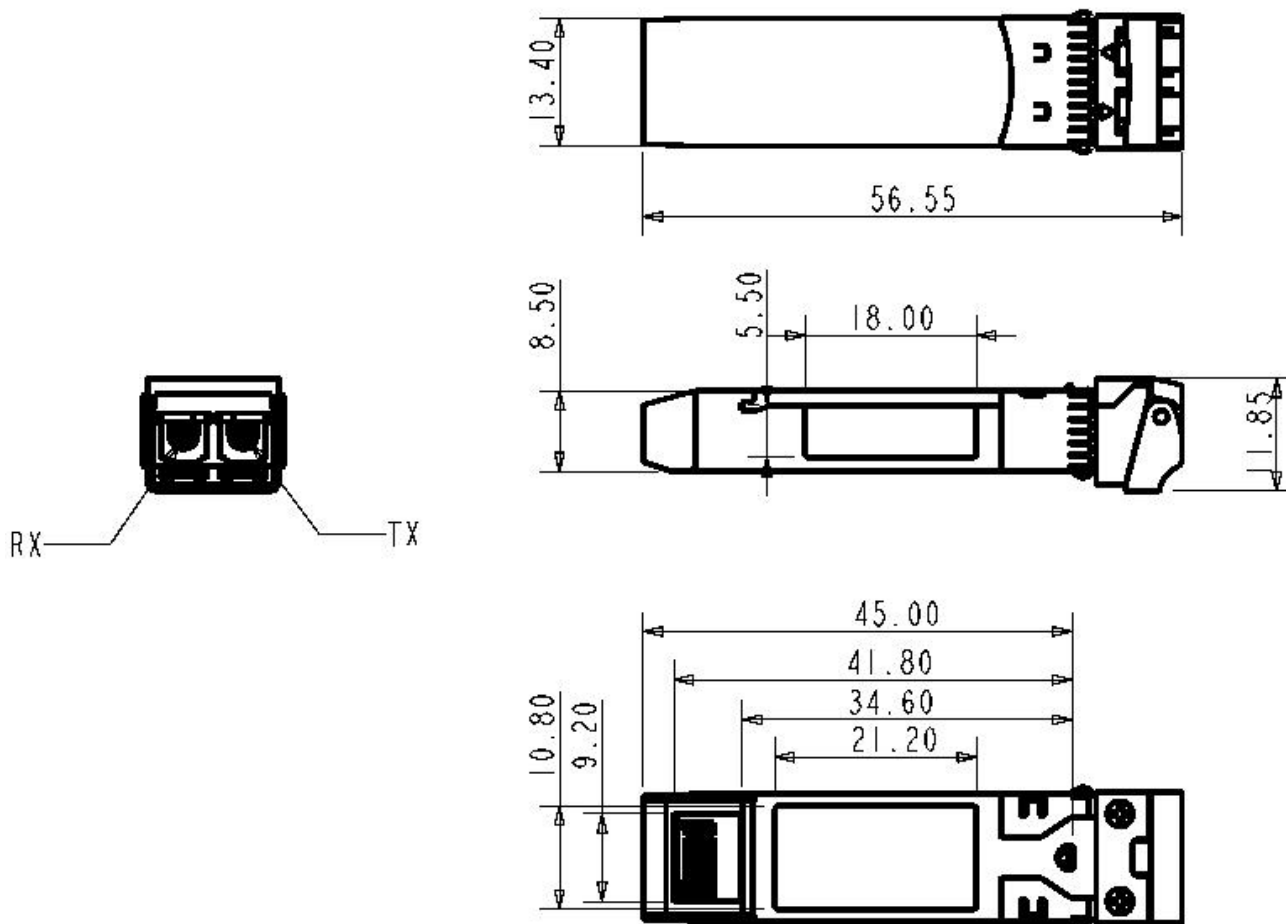

Regulatory Compliance

FIBERSTAMP FBC-D2585M30T transceivers are Class 1 Laser Products. They are certified per the following standards:

Feature	Agency	Standard
Laser Eye Safety	FDA/CDRH	CDRH 21 CFR 1040 and Laser Notice 50
Laser Eye Safety	TÜV	IEC 60825-1:2014 EN 60825-1:2014 EN 60825-2:2004+A1+A2
Electrical Safety	TÜV	EN 60950-1:2006+A11+A1+A12+A2
Electrical Safety	UL/CSA	UL 60950-1 & CAN/CSA C22.2 No.60950-1 CLASS 3862.07 CLASS 3862.87
EMC	FCC	47 CFR FCC Part 15 Subpart B
EMC	CE-EMC	EN 55032:2015 EN 55024:2010+A1:2015 EN 61000-3-2:2014 EN 61000-3-3:2013

Complies with FDA performance standards for laser products except for deviations pursuant to Laser Notice No. 50, dated June 24, 2007.

References

1. SFP MSA
2. eCPRI MSA
3. Directive 2011/65/EU of the European Parliament and of the Council, "on the restriction of the use of certain hazardous substances in electrical and electronic equipment," July 1, 2011.

CAUTION:

Use of controls or adjustment or performance of procedures other than those specified herein may result in hazardous radiation exposure.

Ordering Information

Part Number	Product Description
FBC-D2585M30T	SFP28 SR(Industrial grade), 25.78125/24.33Gb/s, 850nm, 300m on OM4 MMF, LC

Important Notice

Performance figures, data and any illustrative material provided in this data sheet are typical and must be specifically confirmed in writing by FIBERSTAMP before they become applicable to any particular order or contract. In accordance with the FIBERSTAMP policy of continuous improvement specifications may change without notice.

The publication of information in this data sheet does not imply freedom from patent or other protective rights of FIBERSTAMP or others. Further details are available from any FIBERSTAMP sales representative.

