



SFP28 LWDM 20Km I-temp

FBC-D25LxxK20T

Features

- Hot-pluggable SFP28 form factor
- Supports CPRI wireless data rate
- Cooled DML transmitter and APD receiver
- Internal CDR circuits on both receiver and transmitter channels
- Maximum link length : 20Km on SMF
- Duplex LC connector
- Operating case temperature range: -40 to +85°C
- Single 3.3V power supply
- RoHS compliant (lead free) 



Applications

- CPRI Option 10, eCPRI
- 25G Ethernet
- Support 10G CPRI option 8 by CDR bypass

Description

The FIBERSTAMP SFP28 LWDM 20km Transceiver is a "Limiting module", designed for CPRI option10,25GBASE, link length up to 10km on G.652 SMF, link budget can reach 21.5dB.They are compliant with SFF-8431 Rev 4.1, SFF-8432 and SFF-8472 Rev 12.3.The transmitter section incorporates a DML laser, and the receiver section consists of a PIN photodiode integrated with TIA.

Digital diagnostics functions are available via a 2-wire serial interface, as specified in SFF-8472, which allows real-time access to device operating parameters such as case temperature, laser bias current, transmitted optical power, and received optical power and module supply voltage.



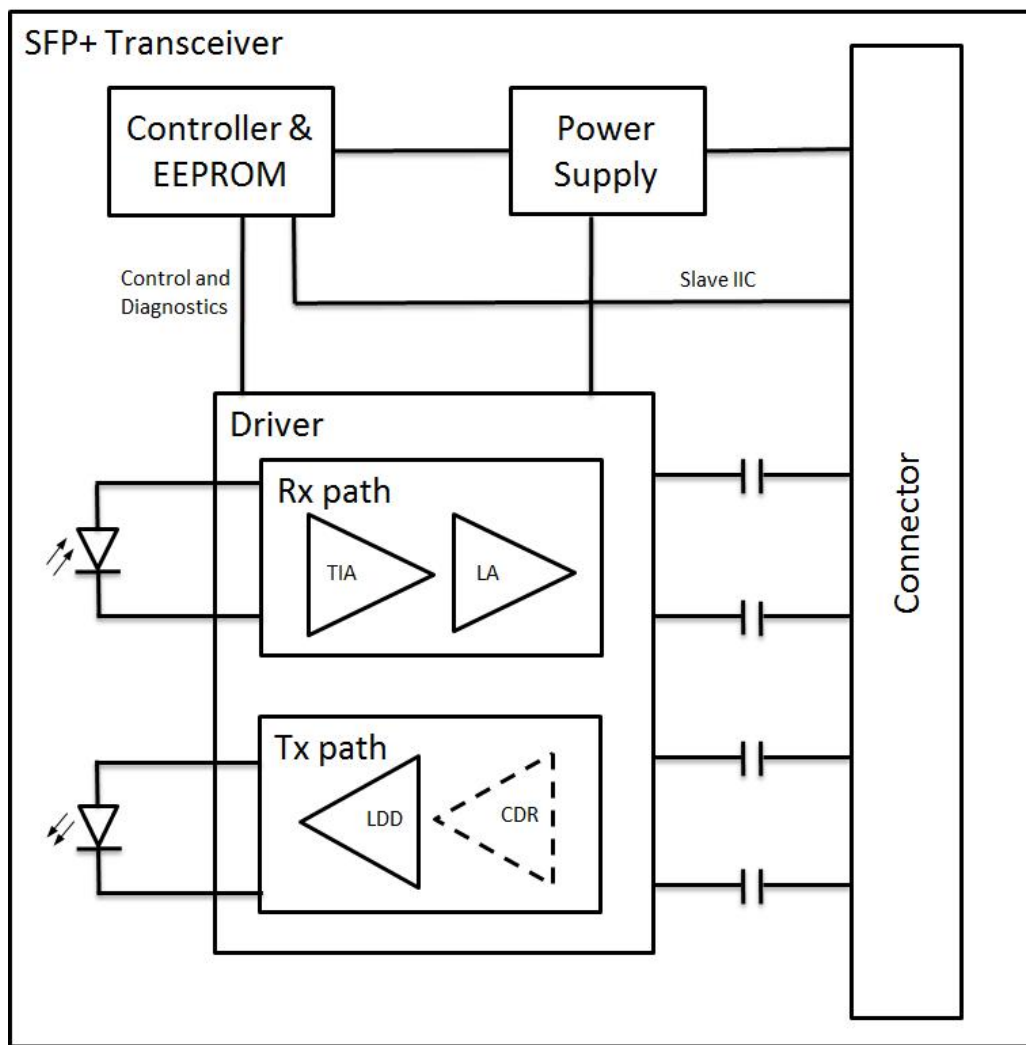

Figure 1. Module Block Diagram

The SFP28 is an Enhanced Small Form Factor Pluggable SFP28 transceivers, and can be contacted through I2C serial interface.

Absolute Maximum Ratings

Parameter	Symbol	Min	Max	Unit
Supply Voltage	Vcc	-0.5	+3.8	V
Operating Case temperature	Top	-40	+85	°C
Operating Relative Humidity	RHop	0	85	%
Storage and Transportation Temperature	Tst	-40	+85	°C
Storage and Transportation Relative Humidity	-	0	85	%
Max Link Length	Lmax		20	km

Operating Conditions

Parameter	Symbol	Min	Typical	Max	Unit
Supply Voltage	Vcc	3.13	3.3	3.47	V
Supply current	Icc	-	450	-	mA
Operating Case temperature	Tca	-40	-	+85	°C
Module Power Dissipation ^[1]	Pm	-	-	2	W
ESD(High speed pins) ^[2]	-	-	-	1000	V

Notes:

1. Power consumption over -40~85°C case temperature and BOL
2. Human body model per JEDEC JESD22-A114-B, compliant with INF-077i Rev.4.5 August 31, 2005



Transmitter Optical Specifications

Parameter	Symbol	Min	Typical	Max	Unit
Laser Safety	Class I according to IEC60825				
Optical Wavelength	λ	1269.23,1273.54,1277.89,1282.26, 1286.66,1291.10,1295.56,1300.05,			nm
Data rate	BR		25.78125	-	Gbps
Wavelength Deviation	$\Delta\lambda$	-2.5		+2.5	nm
Average Optical Power ^[1]	P _{out}	2	-	7	dBm
Optical Transmit Power (disabled)	P _{out_off}	-	-	-30	dBm
Spectral Width (-20dB)	$\Delta\lambda_{20}$	-	-	1	nm
Side Mode Suppression Ratio ^[2]	SMSR	30	-	-	dB
Extinction Ratio	ER	4	-	-	dB

Notes:

1. Average power measured at output over the operating temperature
2. Ratio of the average output power in the dominant longitudinal mode to the power in the most significant side mode peak under full modulation condition

Laser Safety: All transceivers in this datasheet are Class I Laser products per FDA/CDRH and IEC-60825 standards. They must be operated under specified operating conditions.

Receiver Optical Specifications

Parameter	Symbol	Min	Typical	Max	Unit	Note
Input Operating Wavelength	λ	1260	-	1620	nm	
Data rate	BR		25.78125	-	Gbps	
Maximum Input Power	RX-overload		-	-4	dBm	
Rx Damage threshold				-3	dBm	
Average Receive Power	P _{avg}			-4	dBm	
Sensitivity(OMA)	R _{sen1} ^[1]	-	-	-20	dBm	
Sensitivity(OMA)	R _{sen2} ^[2]			-20	dBm	
Loss of Signal Asserted	LOS _A	-31	-	-	dBm	
LOS De-Asserted	LOS _D	-	-	-21	dBm	
LOS Hysteresis	LOS _H	0.5	-		dB	

Notes:

1. Measured with PRBS 2³¹-1, BER <5E⁻⁵, 24.33Gbps.
2. Measured with PRBS 2³¹-1, BER <5E⁻⁵, 25.78Gbps.

Transmitter Specifications – Electrical

Parameter	Symbol	Min	Typical	Max	Unit
Data Rate	BR		25.78125	-	Gbps
Input differential impedance	R _{in}	80	100	120	Ω
Differential data Input	V _{txDIFF}	-	-	900	mVpp
Transmit Disable Voltage	V _D	2.0	-	V _{cc} +0.3	V
Transmit Enable Voltage	V _{en}	-0.3	-	+0.8	V

Parameter	Symbol	Min	Typical	Max	Unit
Transmit Disable Assert Time	t_off	-	-	100	us
Tx Enable Assert Time	t_on	-	-	2	ms
Tx_Fault Assert Time for cooled SFP28	Tx_f_on	-	-	50	ms
Tx_Fault Reset Time ^[1]	t_reset	10	-	-	us
Initialization Time for cooled SFP28	t_start_up	-	-	10	s

Notes:

1. Time Tx_Disable must be held high to reset Tx_Fault

Receiver Specifications – Electrical

Parameter	Symbol	Min	Typical	Max	Unit
Data Rate	BR	-	25.78125	-	Gbps
Differential Output Impedance	Rout	80	100	120	Ω
Differential Output Swing	Vout P-P	-	-	900	mVpp
Rise/Fall Time	Tr / Tf	9.5	-	-	ps
Loss of Signal –Asserted	VOH	2	-	Vcc+0.3	V
Loss of Signal –Negated	VOL	0	-	+0.4	V
LOS Assert/Deassert Time Delay	T_los on/off	-	-	100/100	us

Digital Diagnostic Functions

Parameter	Symbol	Min	Max	Unit	Notes
Accuracy					
Transceiver Temperature	DMI_Temp	-3	+3	°C	
TX Output optical power	DMI_TX	-2	+2	dB	
RX Input optical power	DMI_RX	-2	+2	dB	
Transceiver Supply voltage	DMI_VCC	-3%	+3%	V	Full operating range
Bias current monitor	DMI_Ibias	-10%	10%	mA	

Support Wavelength(nm)

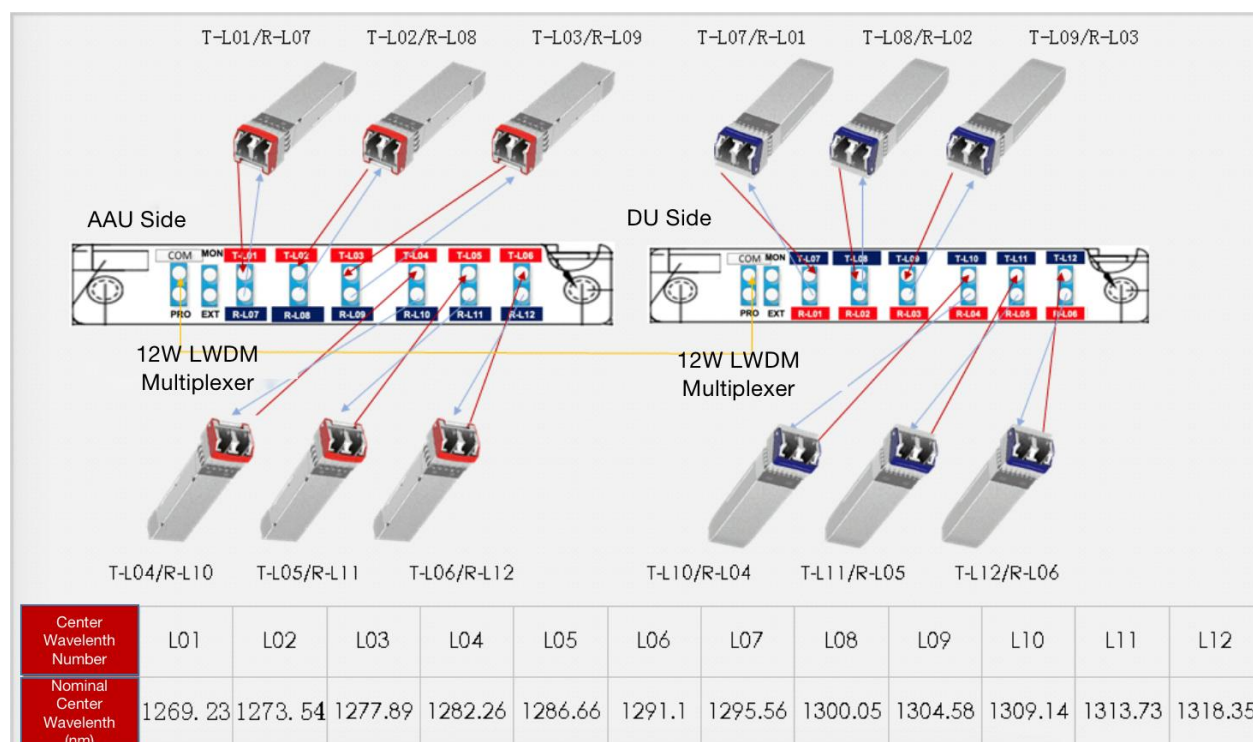

CDR Rate Select control

The soft RS(0) select bit(A2h byte 110 bit3) and soft RS(1) select bit(A2h byte118 bit3) are CDR control bits that allow for the CDR Rate Select using the 2-wire interface. These bits and the corresponding rate select pins RS0 and RS1 are connected through a logical OR function so that the CDR is controlled when either the bit is "1" or the pin is "high".

TABLE 10-2 RETIMER/CDR RATE SELECT LOGIC TABLE

When byte 13d of A0h is set to 0Eh and bit 64.3 of A0h is set to 1			
Logic OR of RS0 pin and RS0 bit	Logic OR of RS1 pin and RS1 bit	Receiver retimer/CDR	Transmitter retimer/CDR
Low/0	Low/0	Lock at low bit rate	Lock at low bit rate
Low/0	High/1	Lock at high bit rate	Bypass
High/1	Low/0	Bypass	Bypass
High/1	High/1	Lock at high bit rate	Lock at high bit rate

Note: Low and high bit rates are defined in byte 13d of A0h.

Figure2. Electrical Pin-out Details

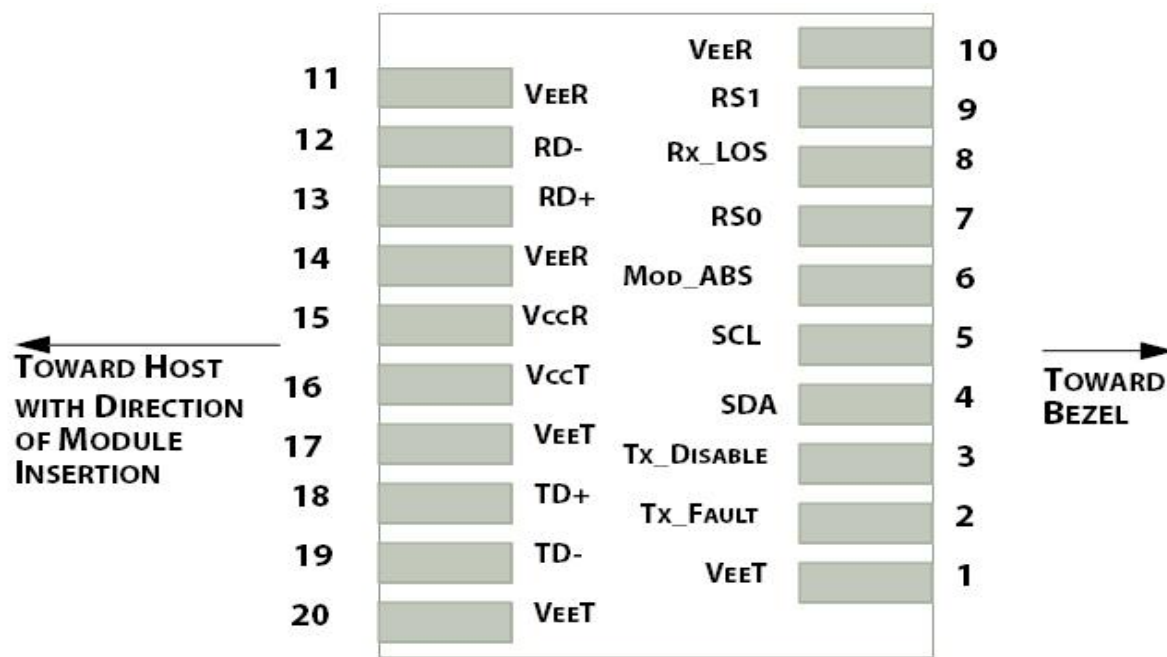

Pin Descriptions

Pin	Symbol	Name/Description
1	VEET [1]	Transmitter Ground
2	Tx_FAULT[2]	Transmitter Fault
3	Tx_DIS[3]	Transmitter Disable. Laser output disabled on high or open
4	SDA [2]	2-wire Serial Interface Data Line
5	SCL [2]	2-wire Serial Interface Clock Line
6	MOD_ABS [4]	Module Absent. Grounded within the module
7	RS0	Rate Select 0
8	RX_LOS [2]	Loss of Signal indication. Logic 0 indicates normal operation
9	RS1	Rate Select 1
10	VEER [1]	Receiver Ground
11	VEER [1]	Receiver Ground
12	RD-	Receiver Inverted DATA out. AC Coupled
13	RD+	Receiver DATA out. AC Coupled
14	VEER [1]	Receiver Ground

Pin	Symbol	Name/Description
15	VCCR	Receiver Power Supply
16	VCCT	Transmitter Power Supply
17	VEET [1]	Transmitter Ground
18	TD+	Transmitter DATA in. AC Coupled
19	TD-	Transmitter Inverted DATA in. AC Coupled
20	VEET [1]	Transmitter Ground

Notes:

1. Module circuit ground is isolated from module chassis ground within the module.
2. Should be pulled up with 4.7k – 10k ohms on host board to a voltage between 3.15V and 3.6V.
3. Tx_Disable is an input contact with a 4.7 kΩ to 10 kΩ pull up to VccT inside the module.
4. Mod_ABS is connected to VeeT or VeeR in the SFP28 module. The host may pull this contact up to Vcc_Host with a resistor in the range 4.7 kΩ to 10 kΩ. Mod_ABS is asserted "High" when the SFP+ module is physically absent from a host slot.

Host Board SFP28 Connector Recommendations

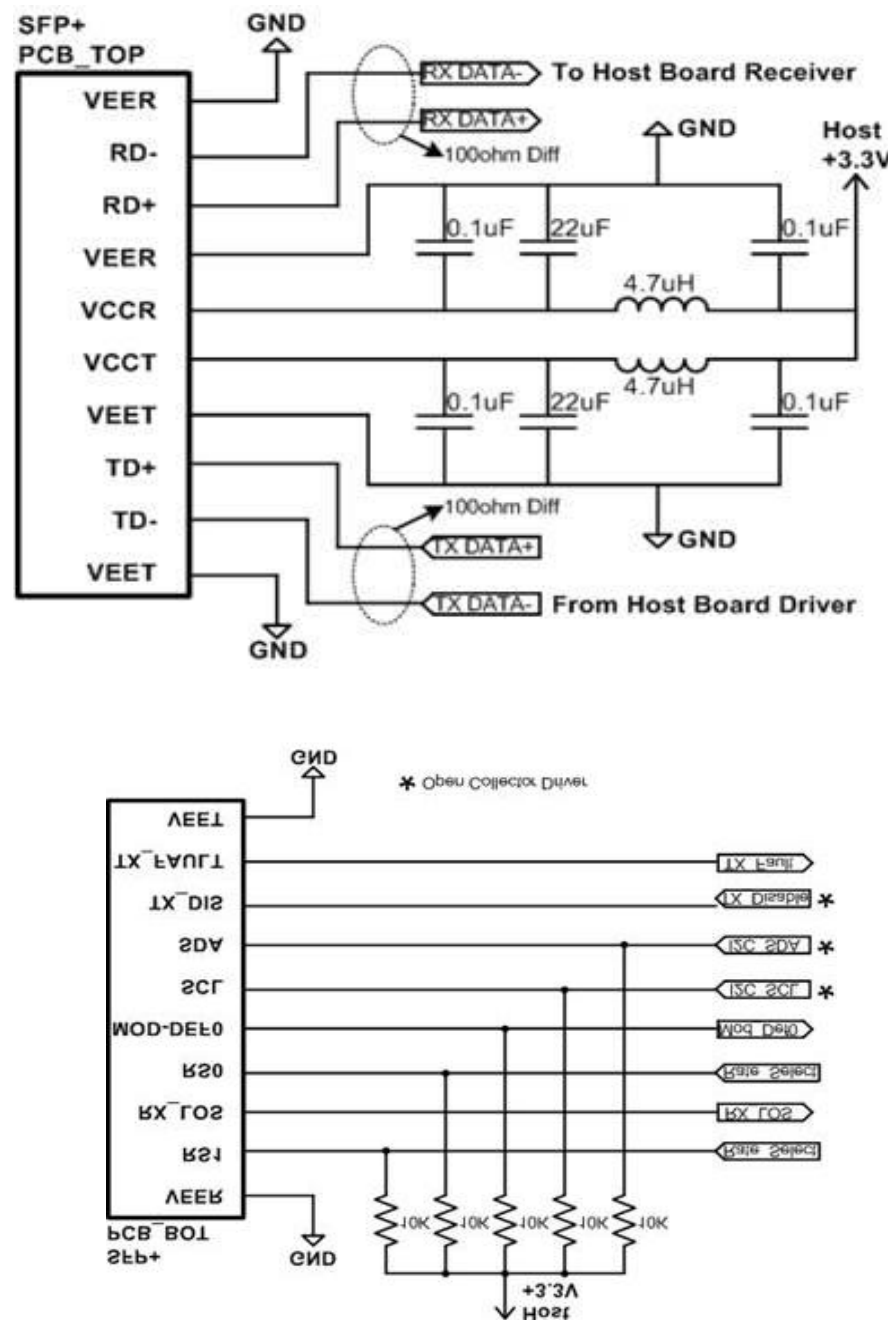

Figure3.Recommended Interface Circuit

Mechanical Dimensions

FIBERSTAMP FBC-D25LxxK20T SFP28 Transceiver are compatible with the SFF-8432 specification for improved pluggable form factor, and shown here for reference purposes only.

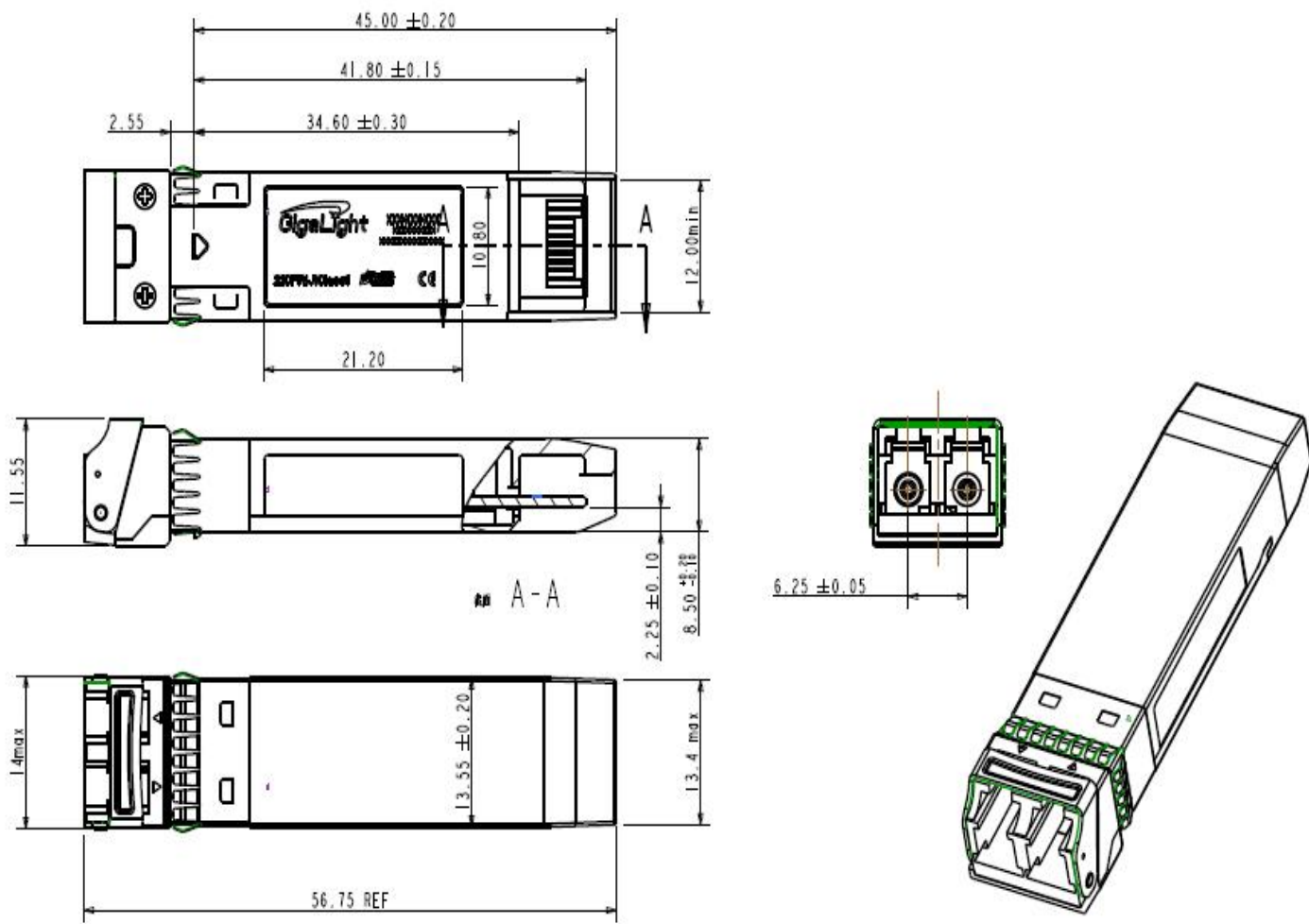

Figure4. Mechanical Specifications

Regulatory Compliance

FIBERSTAMP SFP28 transceiver is designed to be Class I Laser safety compliant. They meet the requirements of the following standards:

Feature	Standard
Laser Safety	IEC 60825-1:2014 (3 rd Edition) IEC 60825-2:2004/AMD2:2010 EN 60825-1-2014
Electrical Safety	EN 62368-1: 2014 IEC 62368-1:2014 UL 62368-1:2014
Environmental protection	Directive 2011/65/EU with amendment(EU)2015/863
CE EMC	EN55032: 2015 EN55035: 2017 EN61000-3-2:2014
FCC	FCC Part 15, Subpart B; ANSI C63.4-2014

References

1. "Specifications for Enhanced Small Form Factor Pluggable Module SFP+", SFF-8431, Rev 4.1, July 6, 2009.
2. "Improved Pluggable Formfactor",SFF-8432, Rev 4.2, Apr 18,2007
3. IEEE802.3cc – 2017
4. "Diagnostic Monitoring Interface for Optical Transceivers" SFF-8472, Rev 10.3, Dec 1,2007

⚠ CAUTION:

Use of controls or adjustment or performance of procedures other than those specified herein may result in hazardous radiation exposure.

Part Number	Product Description
FBC-D25L01K20T	25Gbps 20km LWDM SFP28,-40~+85°C, 1273.54nm, red
FBC-D25L02K20T	25Gbps 20km LWDM SFP28,-40~+85°C, 1277.89nm, red
FBC-D25L03K20T	25Gbps 20km LWDM SFP28,-40~+85°C, 1282.26nm, red
FBC-D25L04K20T	25Gbps 20km LWDM SFP28,-40~+85°C, 1286.66nm, red

Part Number	Product Description
FBC-D25L05K20T	25Gbps 20km LWDM SFP28,-40~+85°C, 1291.10nm, red
FBC-D25L06K20T	25Gbps 20km LWDM SFP28,-40~+85°C, 1295.56nm, blue
FBC-D25L07K20T	25Gbps 20km LWDM SFP28,-40~+85°C, 1300.05nm, blue
FBC-D25L08K20T	25Gbps 20km LWDM SFP28,-40~+85°C, 1304.58nm, blue
FBC-D25L09K20T	25Gbps 20km LWDM SFP28,-40~+85°C, 1309.14nm, blue
FBC-D25L10K20T	25Gbps 20km LWDM SFP28,-40~+85°C, 1313.73nm, blue
FBC-D25L11K20T	25Gbps 20km LWDM SFP28,-40~+85°C, 1318.35nm, blue

Important Notice

Performance figures, data and any illustrative material provided in this data sheet are typical and must be specifically confirmed in writing by FIBERSTAMP before they become applicable to any particular order or contract. In accordance with the FIBERSTAMP policy of continuous improvement specifications may change without notice.

The publication of information in this data sheet does not imply freedom from patent or other protective rights of FIBERSTAMP or others. Further details are available from any FIBERSTAMP sales representative.

