

Industrial 25G CWDM SFP28 10km Optical Transceivers

Features

- Hot-pluggable SFP28 form factor
- Supports CPRI wireless data rate
- Cooled EML transmitter and APD receiver
- Suitable for use in 20nm channel spacing CWDM systems
- Internal CDR circuits on both receiver and transmitter channels
- Maximum power dissipation: 1.8W
- Maximum link length: 10Km on SMF
- Duplex LC connector
- Operating case temperature range: -40 to +85°C
- Single 3.3V power supply
- RoHS compliant (lead free)

Applications

- CPRI Option 10
- 25G Ethernet

Description

This product is a 24.33~25.78Gbps transceiver, designed for optical communication compliant to CPRI Option 10 standard and 25G Ethernet. Its high performance cooled CWDM EML transmitter and high sensitivity APD receiver provide superior performance for CPRI/Ethernet application up to 10km (with FEC) Links. The product is designed with form factor, optical/electrical connection according to the SFP28 Multi-Source Agreement (MSA).

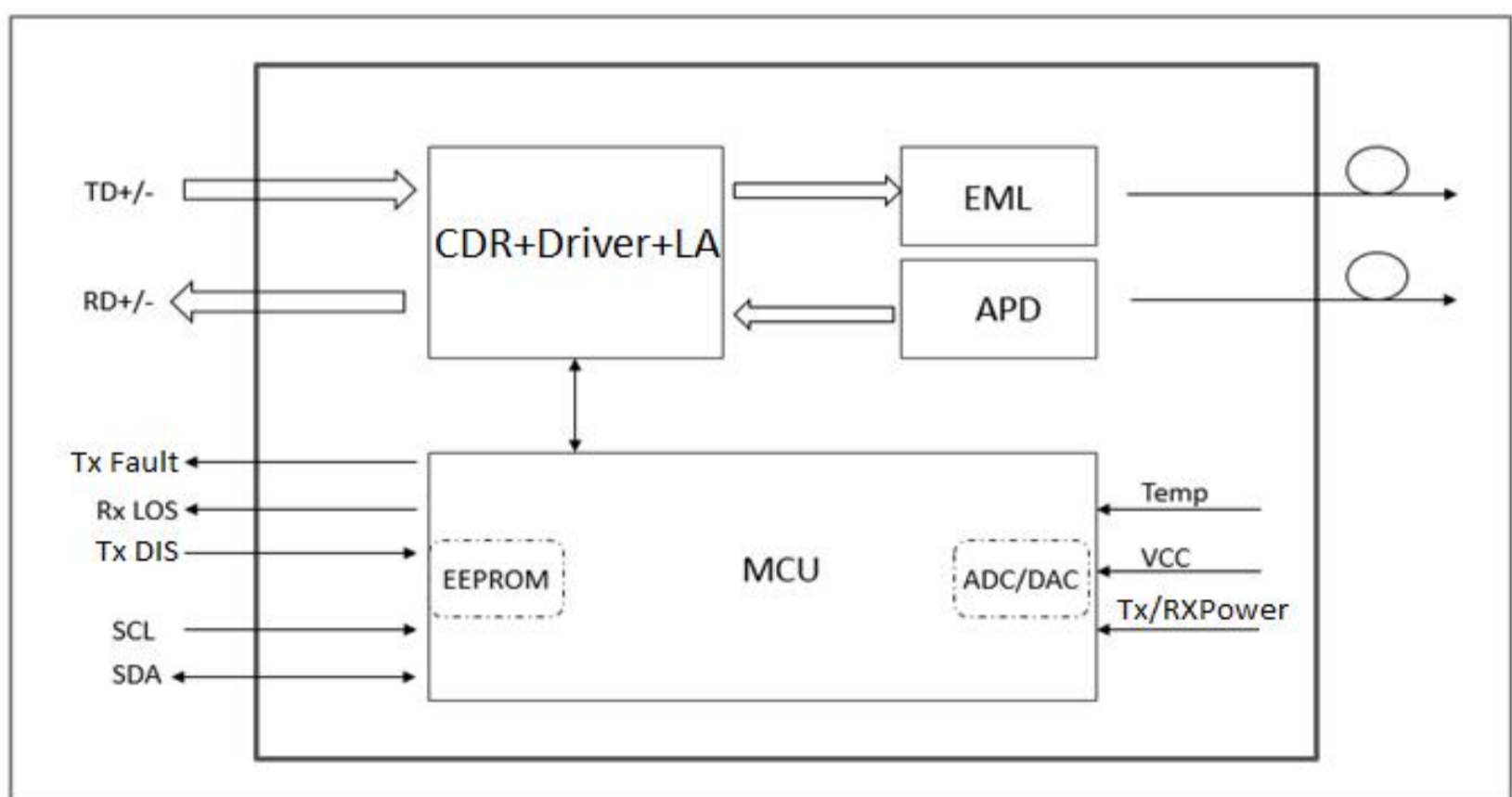

Figure 1. Module Block Diagram

The SFP28 is a Enhanced Small Form Factor Pluggable SFP28 transceivers, and can be contacted through I2C serial interface.



Absolute Maximum Ratings

Parameter	Symbol	Min	Max	Unit
Supply Voltage	Vcc	-0.5	+3.8	V
Operating Case temperature	Top	-40	+85	°C
Operating Relative Humidity	RHop	0	85	%
Storage and Transportation Temperature	Tst	-40	+85	°C
Storage and Transportation Relative Humidity	-	0	85	%
Max Link Length	Lmax		10	km

Operating Conditions

Parameter	Symbol	Min	Typical	Max	Unit
Supply Voltage	Vcc	3.13	3.3	3.47	V
Supply current	Icc	-	-	546	mA
Operating Case temperature	Tca	-40	-	+85	°C
Module Power Dissipation ¹	Pm	-	-	1.8	W
ESD(High speed pins) ²	-	-	-	1000	V

Notes:

1. Power consumption over -40~85°C case temperature and BOL
2. Human body model per JEDEC JESD22-A114-B,compliant with INF-077i Rev.4.5 August 31, 2005.

Transmitter Optical Specifications

Parameter	Symbol	Min	Typical	Max	Unit
Laser Safety	Class I according to IEC60825				
Optical Wavelength	λ	As per ITU-T G.694.2			nm
Data rate	BR	24.33	25.78125	-	Gbps
Wavelength Deviation ³	$\Delta\lambda$	-6.5		+6.5	nm
Average Optical Power ¹	Pout	-2	-	+2	dBm
Optical Transmit Power (disabled)	Pout_off	-	-	-30	dBm
Spectral Width (-20dB)	$\Delta\lambda_{20}$	-	-	1	nm
Side Mode Suppression Ratio ²	SMSR	24	-	-	dB
Extinction Ratio	ER	3.5	-	-	dB

Notes:

1. Average power measured at output over the operating temperature.
2. Ratio of the average output power in the dominant longitudinal mode to the power in the most significant side mode peak under full modulation condition.
3. Deviation from the ITU G.694.2, wavelength range 1471nm~1571nm

Laser Safety: All transceivers in this datasheet are Class I Laser products per FDA/CDRH and IEC-60825 standards.They must be operated under specified operating conditions.



Receiver Optical Specifications

Parameter	Symbol	Min	Typical	Max	Unit	Note
Input Operating Wavelength	λ	1260	-	1620	nm	
Data rate	BR	24.33	25.78125	-	Gbps	
Maximum Input Power	RX-overload	0	-		dBm	
Average Receive Power	Pavg	-14		2	dBm	
Sensitivity(OMA) (10km,24.33)	Rsen1 ¹	-	-	-13	dBm	
Sensitivity(OMA) (10km,25.78)	Rsen2 ²			-13	dBm	
Loss of Signal Asserted	LOS _A	-30	-	-	dBm	
LOS De-Asserted	LOS _D	-	-	-15	dBm	
LOS Hysteresis	LOS _H	0.5	-		dB	

Notes:

1. Measured with PRBS 2³¹-1, BER < 1E⁻¹²
2. Measured with PRBS 2³¹-1, BER < 5E⁻⁵

Transmitter Specifications – Electrical

Parameter	Symbol	Min	Typical	Max	Unit
Data Rate	BR	24.33	25.78125	-	Gbps
Input differential impedance	R _{in}	80	100	120	Ω
Differential data Input	V _{txDIFF}	-	-	900	mVpp
Transmit Disable Voltage	VD	2.0	-	V _{cc} +0.3	V
Transmit Enable Voltage	V _{en}	-0.3	-	+0.8	V
Transmit Disable Assert Time	t _{off}	-	-	100	us
Tx Enable Assert Time	t _{on}	-	-	2	ms
Tx_Fault Assert Time for cooled SFP28	Tx_f_on	-	-	50	ms
Tx_Fault Reset Time ¹	t _{reset}	10	-	-	us
Initialization Time for cooled SFP28	t _{start_up}	-	-	10	s

Notes:

1. Time Tx_Disable must be held high to reset Tx_Fault

Receiver Specifications – Electrical

Parameter	Symbol	Min	Typical	Max	Unit
Data Rate	BR	24.33	25.78125	-	Gbps
Differential Output Impedance	R _{out}	80	100	120	Ω
Differential Output Swing	V _{out P-P}	-	-	900	mVpp
Rise/Fall Time	Tr / Tf	9.5	-	-	ps
Loss of Signal –Asserted	VOH	2	-	V _{cc} +0.3	V
Loss of Signal –Negated	VOL	0	-	+0.4	V



LOS Assert/Deassert Time Delay	T_los on/off	-	-	100/100	us
--------------------------------	--------------	---	---	---------	----

Digital Diagnostic Functions

Parameter	Symbol	Min.	Max	Unit	Notes
Accuracy					
Transceiver Temperature	DMI_Temp	-3	+3	°C	
TX Output optical power	DMI_TX	-2	+2	dB	
RX Input optical power	DMI_RX	-2	+2	dB	
Transceiver Supply voltage	DMI_VCC	-3%	+3%	V	Full operating range
Bias current monitor	DMI_Ibias	-10%	10%	mA	

Support Wavelength

Wavelength (nm)
1471
1491
1511
1531
1551
1571

Table 1. Product ordering codes: the central wavelength is defined as per ITU-T G.694.2.

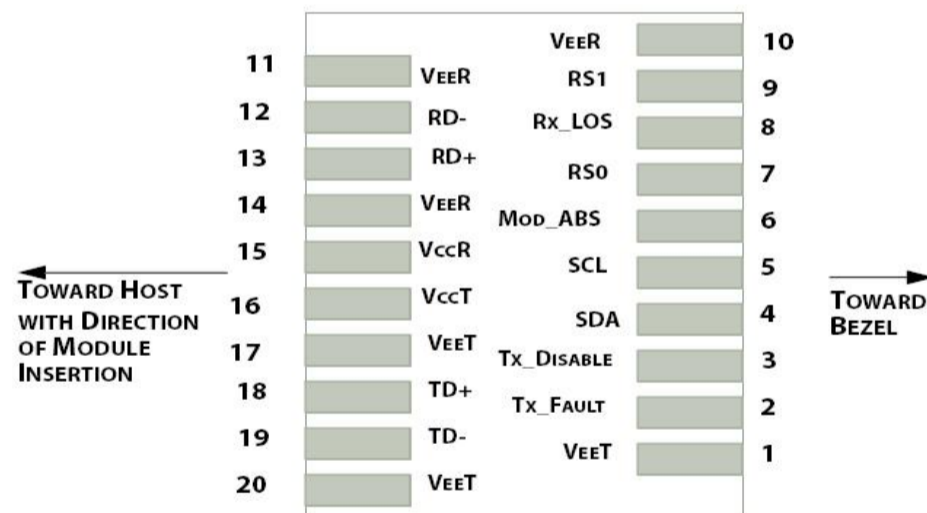

Figure 2. Electrical Pin-out Details

Pin Descriptions

Pin	Symbol	Name/Description
1	VEET ¹	Transmitter Ground
2	Tx_FAULT ²	Transmitter Fault
3	Tx_DIS ³	Transmitter Disable. Laser output disabled on high or open
4	SDA ²	2-wire Serial Interface Data Line
5	SCL ²	2-wire Serial Interface Clock Line
6	MOD_ABS ⁴	Module Absent. Grounded within the module
7	RS0	Rate Select 0



8	RX_LOS ²	Loss of Signal indication. Logic 0 indicates normal operation
9	RS1	Rate Select 1
10	VEER ¹	Receiver Ground
11	VEER ¹	Receiver Ground
12	RD-	Receiver Inverted DATA out. AC Coupled
13	RD+	Receiver DATA out. AC Coupled
14	VEER ¹	Receiver Ground
15	VCCR	Receiver Power Supply
16	VCCT	Transmitter Power Supply
17	VEET ¹	Transmitter Ground
18	TD+	Transmitter DATA in. AC Coupled
19	TD-	Transmitter Inverted DATA in. AC Coupled
20	VEET ¹	Transmitter Ground

Notes:

1. Module circuit ground is isolated from module chassis ground within the module.
2. should be pulled up with 4.7k – 10k ohms on host board to a voltage between 3.15V and 3.6V.
3. Tx_Disable is an input contact with a 4.7 kΩ to 10 kΩ pullup to VccT inside the module.
4. Mod_ABS is connected to VeeT or VeeR in the SFP28 module. The host may pull this contact up to Vcc_Host with a resistor in the range 4.7 kΩ to 10 kΩ. Mod_ABS is asserted “High” when the SFP+ module is physically absent from a host slot.

Host Board SFP28 Connector Recommendations



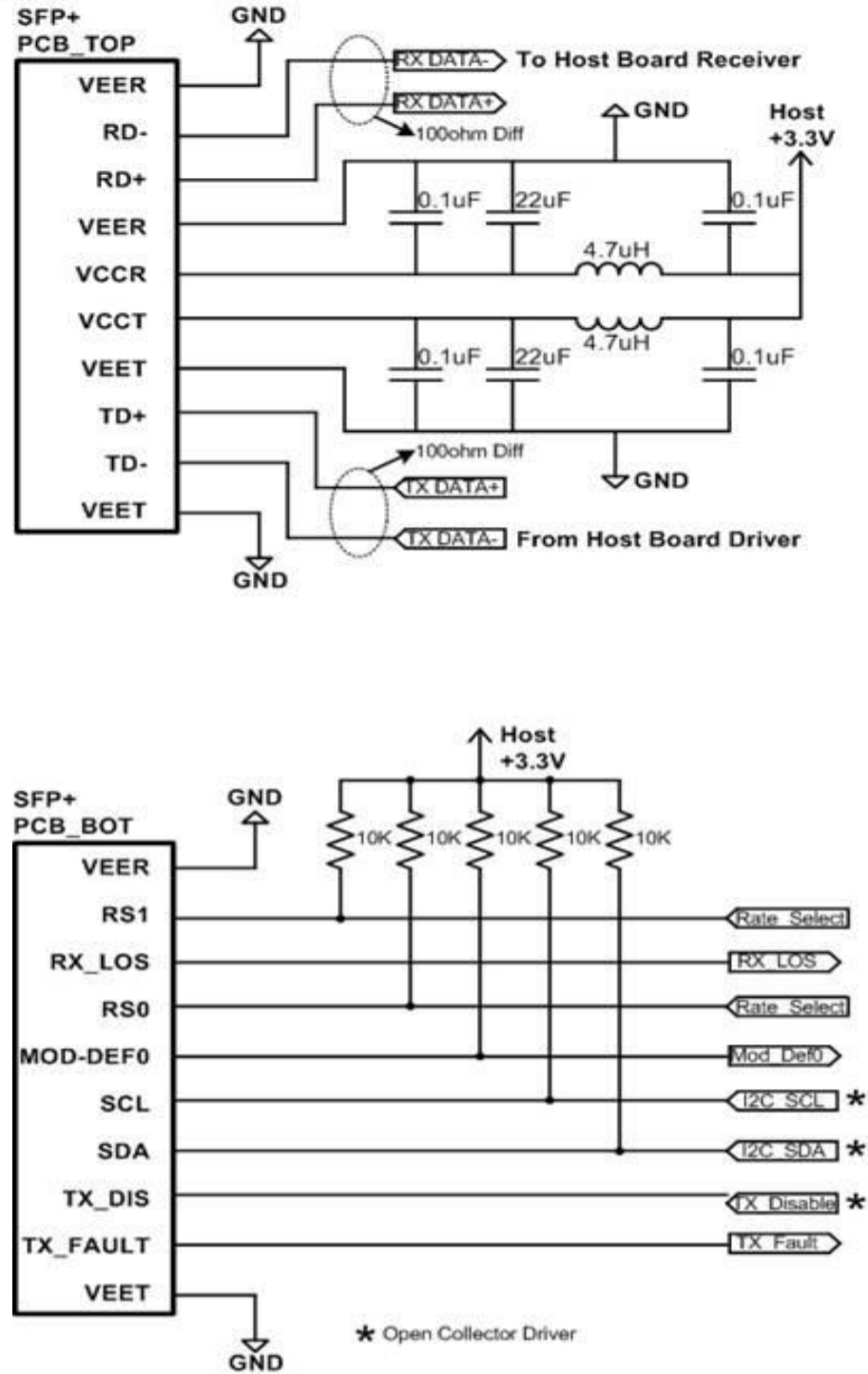

Figure 3. Recommended Interface Circuit

Mechanical Dimensions

FiberStamp SFP28 Transceivers are compatible with the SFF-8432 specification for improved pluggable form factor, and shown here for reference purposes only.

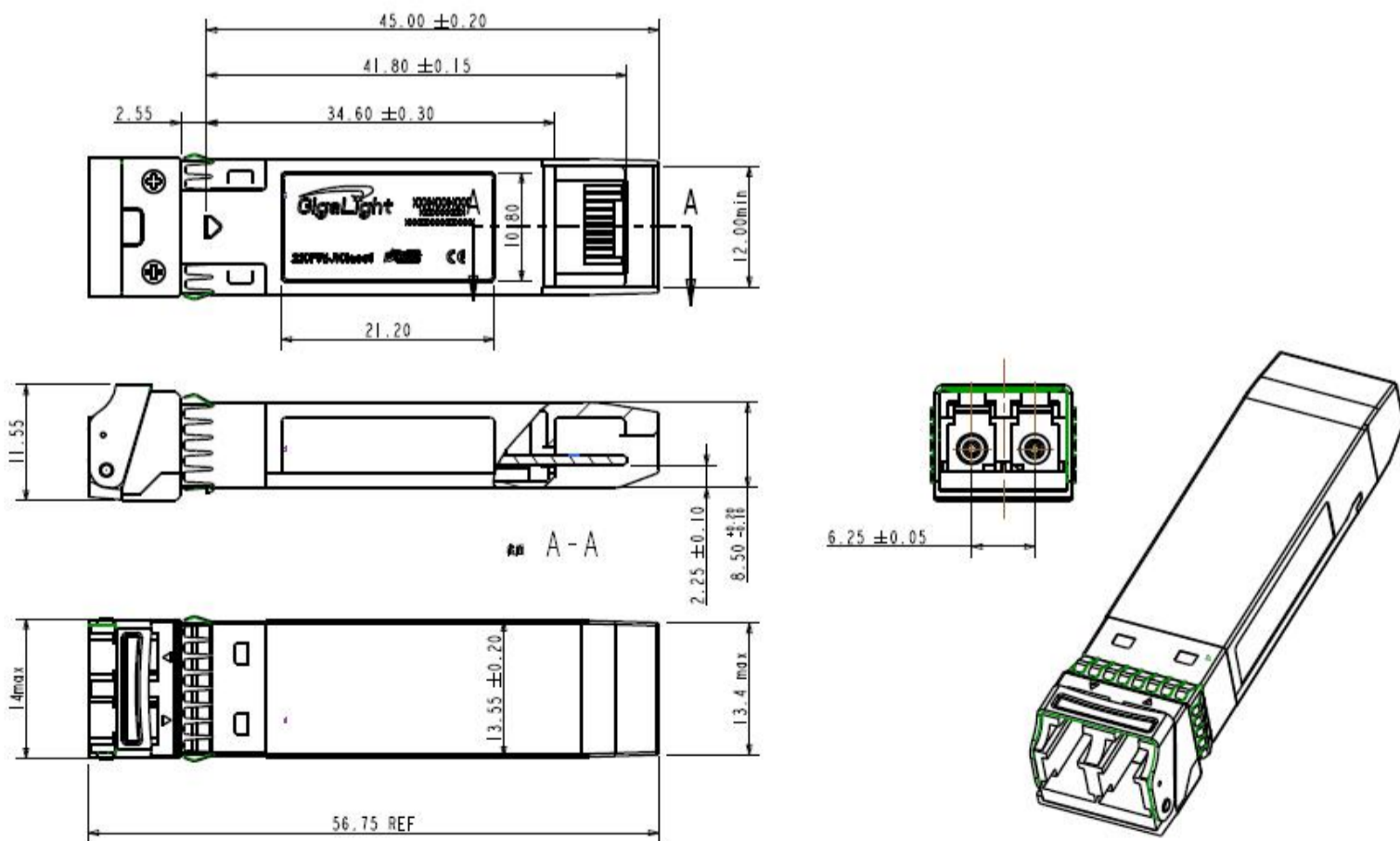

Figure 4. Mechanical Specifications



Regulatory Compliance

FiberStamp SFP28 transceiver is designed to be Class I Laser safety compliant and is certified per the following standards:

Feature	Standard
Laser Safety	IEC 60825-1:2014 (Third Edition) CDRH 21 CFR 1040 and Laser Notice No. 50
Product Safety	IEC/EN/UL 62368-1
Environmental protection	2011/65/EU REACH NO.1907/2006
CE EMC	EN55032: 2015 EN55035: 2017 EN61000-3-2:2014 EN61000-3-3:2013
FCC	FCC Part 15, Subpart B; ANSI C63.4-2014

References

1. "Specifications for Enhanced Small Form Factor Pluggable Module SFP+", SFF-8431, Rev 4.1, July 6, 2009.
2. "Improved Pluggable Form factor",SFF-8432, Rev 4.2, Apr 18,2007
3. IEEE802.3cc – 2017
4. "Diagnostic Monitoring Interface for Optical Transceivers" SFF-8472, Rev 10.3, Dec 1,2007

⚠️ CAUTION:

Use of controls or adjustment or performance of procedures other than those specified herein may result in hazardous radiation exposure.

Ordering information

Part Number	Product Description
FST-25G-47C10-I	Industrial 25G CWDM SFP28 1470nm 10km Optical Transceiver
FST-25G-49C10-I	Industrial 25G CWDM SFP28 1490nm 10km Optical Transceiver
FST-25G-51C10-I	Industrial 25G CWDM SFP28 1510nm 10km Optical Transceiver
FST-25G-53C10-I	Industrial 25G CWDM SFP28 1530nm 10km Optical Transceiver
FST-25G-55C10-I	Industrial 25G CWDM SFP28 1550nm 10km Optical Transceiver
FST-25G-57C10-I	Industrial 25G CWDM SFP28 1570nm 10km Optical Transceiver

Important Notice

Performance figures,data and any illustrative material provided in this data sheet are typical and must be specifically confirmed in writing by FiberStamp before they become applicable to any particular order or contract. In accordance with the FiberStamp policy of continuous improvement specifications may change without notice.

The publication of information in this data sheet does not imply freedom from patent or other protective rights of FiberStamp or others. Further details are available from any FiberStamp sales representative.

