

HDMI 2.0 Active Optical Cables

FSA-H18G-xxxM

Features

- Extend HDMI signals up to 100m over MMF
- Compliant to all links with HDMI Type-A connectors
- Compliant with HDMI 2.0 and Category 2 (600MHz clock frequency) specifications
- 850nm VCSEL Array transmitters, PIN Array photo-detector receivers
- Support 4K@60/3D/1080p/1080i/720p format
- Support DHCP/EDID/CEC/DDC/Audio
- Data rate up to 18Gbps (6Gbps per channel)
- Plug and play, no software to be installed
- Longer, thinner hybrid cable without EMI/RFI emissions
- Low power consumption
- Operating case temperature: 0 to 60°C
- All-metal housing for superior EMI performance
- RoHS compliant (lead free)



Applications

- Blue-ray, DVR, projector
- Video Games
- Computers and mobile to 4K@60 display

Description

The FiberStamp HDMI 2.0 active optical cables are used to extend the transmission distance between HDMI Source and Sink devices. The transmission distance can be up to 100m through a hybrid cable consisting of optical fibers and copper wires. The high-speed TMDS signals are transmitted through multimode fibers, while the low frequency DDC and control signals are transmitted through the copper wires (see Figure 1).

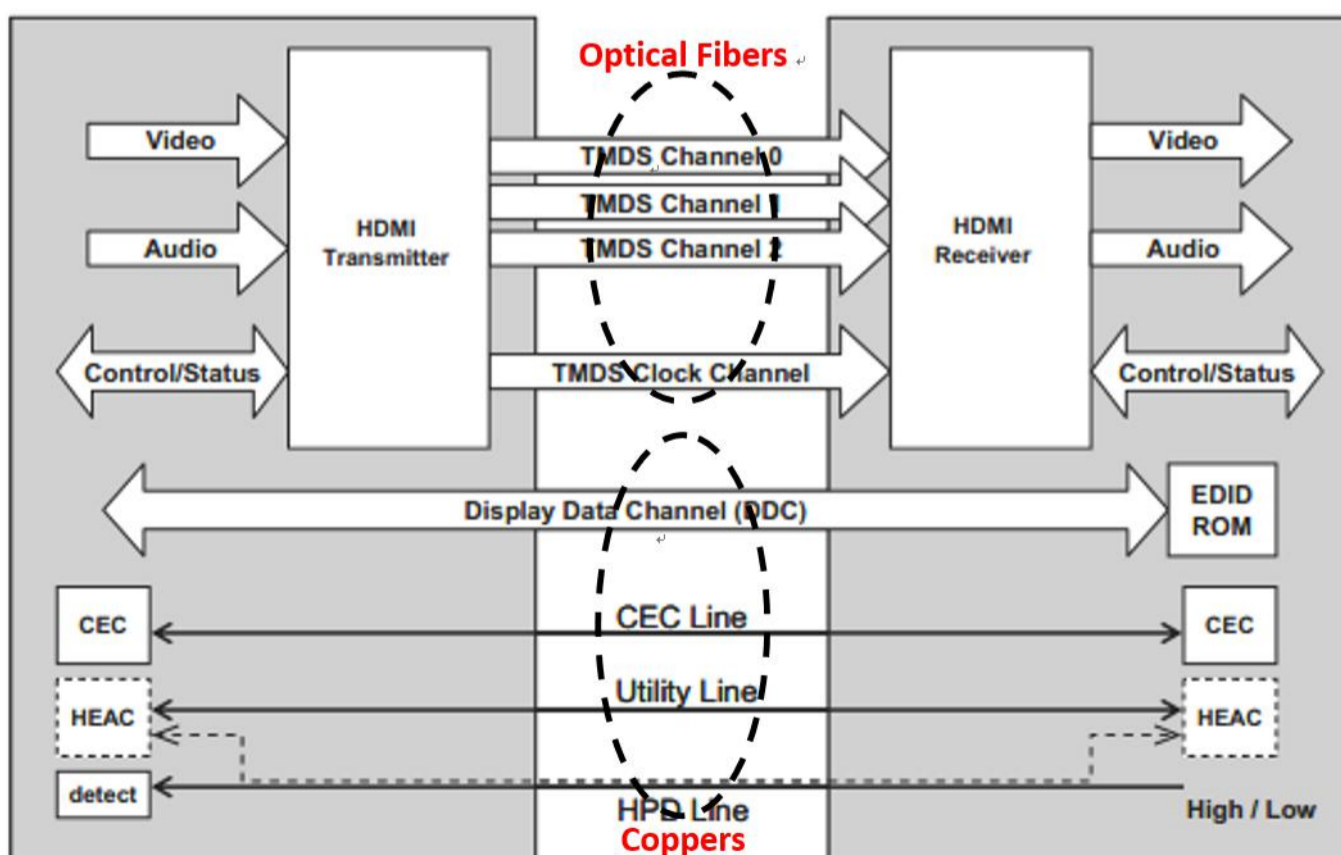

Figure 1. HDMI2.0 Block Diagram



At the ends of the hybrid cable are a transmitter with a Type-A plug connected to the source devices and a receiver with a Type-A plug connected to the sink devices. Inside the transmitter, the electrical TMDS signals are converted into optical signals by the VCSEL array; while in the receiver, the optical signals are converted back into electrical TMDS signals by the photo-diode array.

The optical sub-assemblies inside the transmitter and the receiver are produced by hybrid integration technology. Semiconductor process and passive aligned optical coupling make the product cost effective. The resulting compact dimensions can meet the specifications of HDMI Type-A plug.

It is feasible to connect any HDMI devices such as Blue-ray, DVR, projector, video games, computers and mobile to enjoy the high quality display (see figure 2).

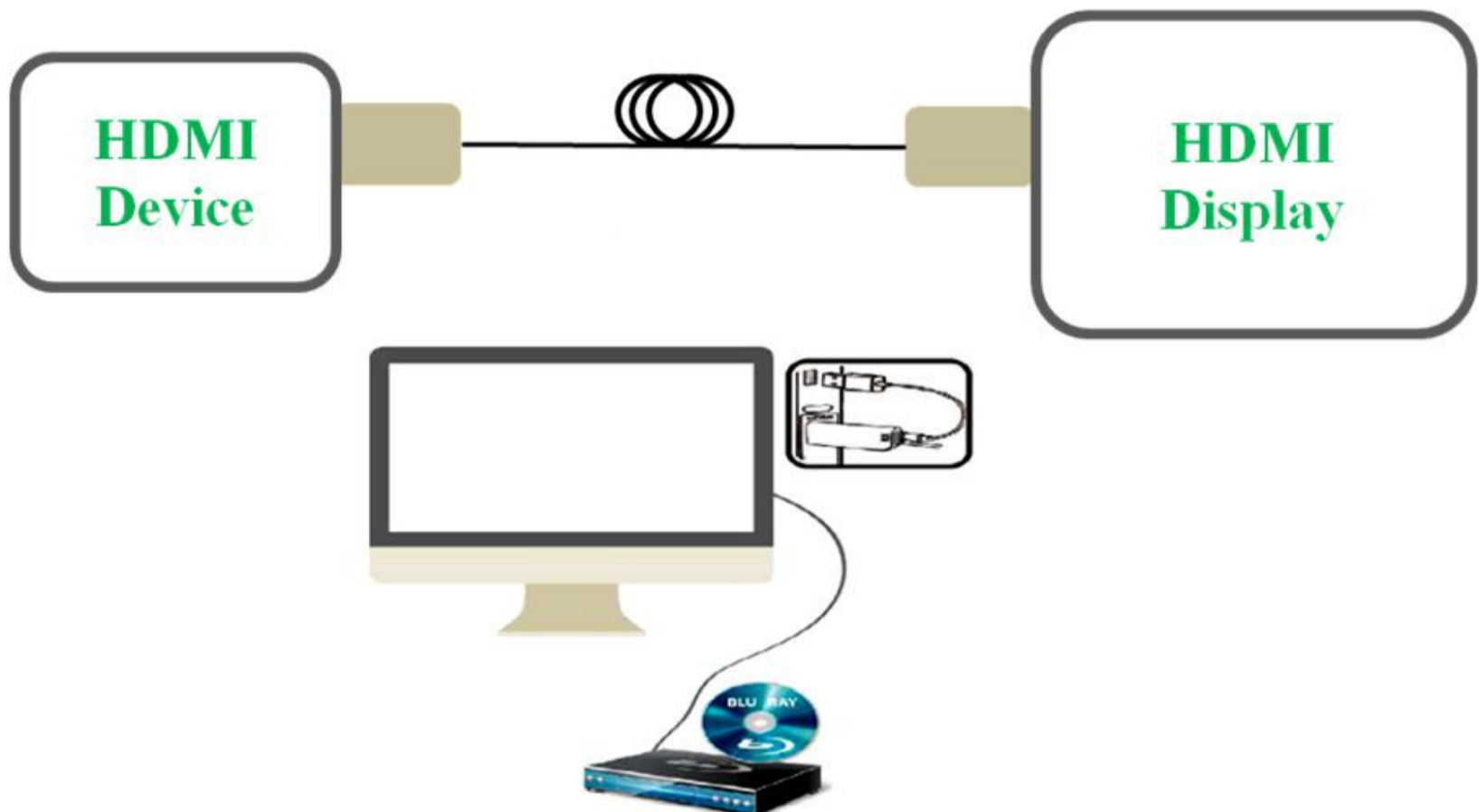

Figure 2. HDMI2.0 up to 4k@60 Block Diagram

Specifications

Parameter	Description
Support HDMI ver.	HDMI 2.0
Data Rate	18Gbps(6GBbps per channel)
Video format	4K@60 /3D/1080p/1080i/720p
Support features	HDCP/EDID/CEC/DDC/Audio
Signal input & output connector	HDMI A-type (Plug)
Fiber length	Up to 100m4/xigai1
Operating Case Temperature	0 to + 60°C
Storage Temperature	-20 to + 85°C
Supply Voltage	5.0V
Supply current	Max. 100mA per end typical
Fiber Bend Radius	Min. 45mm



Pin Description

Pin	Signal Assignment	Name/Description
1	TMDS Data2+	Signal
2	TMDS Data2 Shield	GND
3	TMDS Data2-	Signal
4	TMDS Data1+	Signal
5	TMDS Data1 Shield	GND
6	TMDS Data1-	Signal
7	TMDS Data0+	Signal
8	TMDS Data0 Shield	GND
9	TMDS Data0-	Signal
10	TMDS Clock+	Clock
11	TMDS Clock Shield	GND
12	TMDS Clock-	Clock
13	CEC	Controller
14	Utility	User Defined
15	SCL	IIC
16	SDA	IIC
17	DDC/CEC GND	GND
18	+5V Power	Power
19	Hot Plug Detect	HPD

Mechanical Dimensions

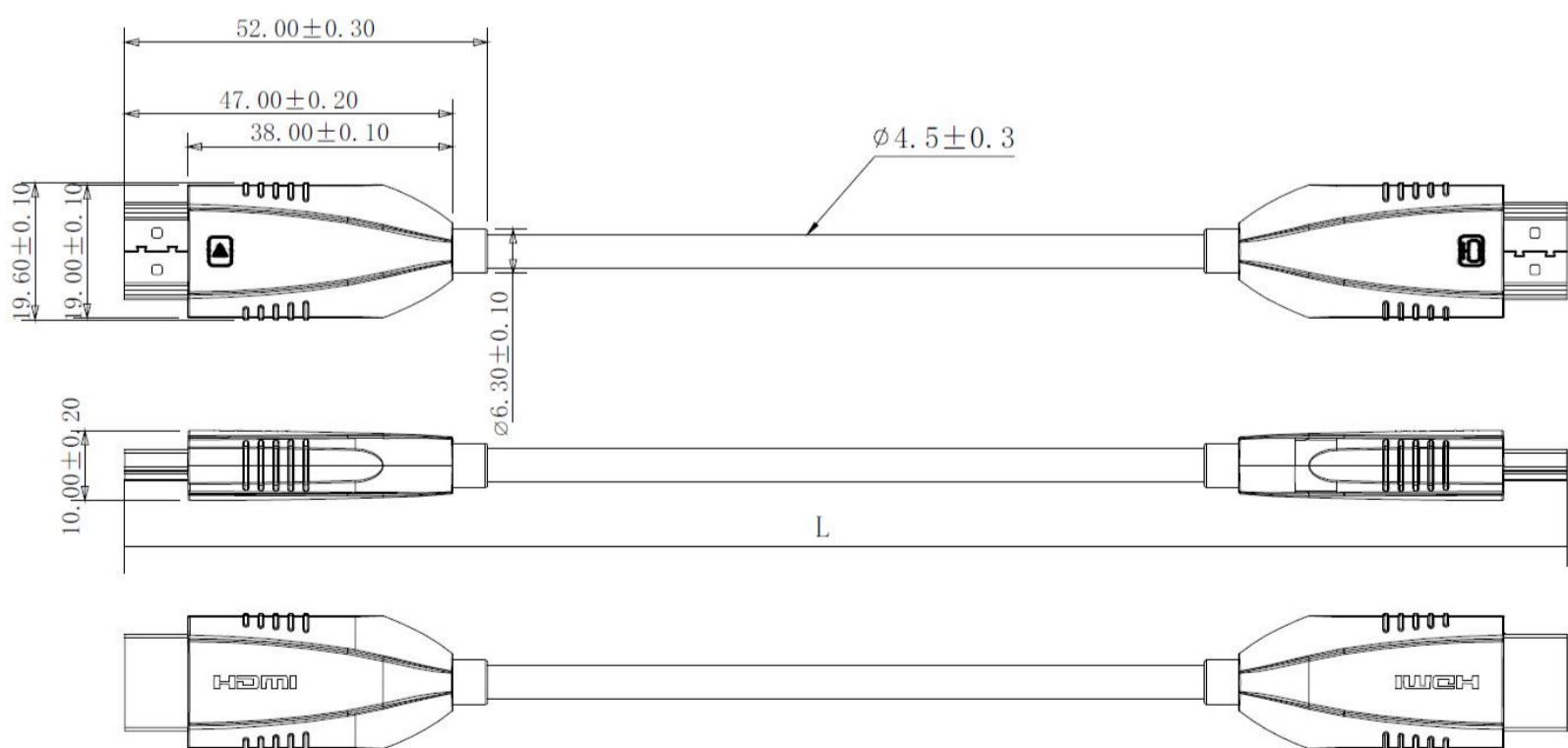

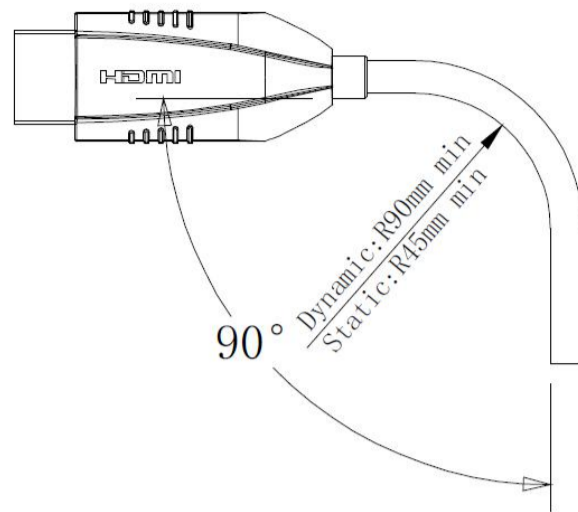

proportion: 1:2

Figure 3. Mechanical Specifications

Regulatory Compliance

The FiberStamp HDMI 2.0 AOCs are Class 1 Laser Products. They are certified per the following standards:

Feature	Agency	Standard
Laser Eye Safety	FDA/CDRH	CDRH 21 CFR 1040 and Laser Notice 50
Laser Eye Safety	TÜV	EN 60825-1:2007 EN 60825-2:2004+A1+A2
Electrical Safety	TÜV	EN 60950
Electrical Safety	UL/CSA	CLASS 3862.07 CLASS 3862.87

Complies with FDA performance standards for laser products except for deviations pursuant to Laser Notice No. 50, dated June 24, 2007.

⚠ CAUTION:

Use of controls or adjustment or performance of procedures other than those specified herein may result in hazardous radiation exposure.

Ordering Information

Part Number	Description
FSA-H18G-001M	HDMI 2.0 Active Optical Cable, 1-Meter
FSA-H18G-002M	HDMI 2.0 Active Optical Cable, 2-Meter
FSA-H18G-003M	HDMI 2.0 Active Optical Cable, 3-Meter
FSA-H18G-004M	HDMI 2.0 Active Optical Cable, 4-Meter
FSA-H18G-005M	HDMI 2.0 Active Optical Cable, 5-Meter
FSA-H18G-006M	HDMI 2.0 Active Optical Cable, 6-Meter
FSA-H18G-007M	HDMI 2.0 Active Optical Cable, 7-Meter
FSA-H18G-008M	HDMI 2.0 Active Optical Cable, 8-Meter
FSA-H18G-009M	HDMI 2.0 Active Optical Cable, 9-Meter
...	...
FSA-H18G-100M	HDMI 2.0 Active Optical Cable, 100-Meter



Important Notice

Performance figures, data and any illustrative material provided in this data sheet are typical and must be specifically confirmed in writing by FiberStamp before they become applicable to any particular order or contract. In accordance with the FiberStamp policy of continuous improvement specifications may change without notice.

The publication of information in this data sheet does not imply freedom from patent or other protective rights of FiberStamp or others. Further details are available from any FiberStamp sales representative.

