

100GE/OTU4 CFP2 SR10 850nm 400m Optical Transceiver Module

Features

- Hot-pluggable CFP2 form-factor
- 10 channels full-duplex transceiver module
- 10x 850nm VCSEL array and PIN photo-detector array
- Internal CDR circuits on both receiver and transmitter channels
- Compliant with CFP2 MSA, IEEE 802.3ba 100GBASE-SR10 and OTN OTU4
- Data rate up to 111.8Gbps
- Power consumption < 8W
- Reach up to 300m (OM3) and 400m (OM4) over MMF
- MPO24 receptacle
- MDIO digital diagnostic interface and control capabilities
- Operating case temperature range from 0°C to 70°C
- 3.3V power supply voltage
- RoHS compliant (lead free)



Applications

- 100GBE interconnects
- High-speed core router connections & Datacom /Telecom switch
- Data aggregation and backplane applications
- Proprietary protocol and density application

Description

The FiberStamp 100GE/OTU4 CFP2 SR10 850nm 400m Optical Transceiver Module is a high performance, low power consumption, short reach interconnect solution supporting 100G Ethernet and Telecom. It is compliant with the CFP2 MSA and IEEE P802.3ba 100GBASE-SR10. FiberStamp CFP2 SR10 modules offer 10 transmit and 10 receive asynchronous channels operating at up to 11.18Gbps per channel.

As shown in Figure 1, the transmitter side of the module consists of an array of VCSELS (Vertical Cavity Surface Emitting Lasers) and associated circuitry, which converts 10 parallel electrical data inputs to 10 parallel optical data output signals and also converts 10 parallel optical signals into 10 parallel electrical signals through an array of PIN photodiodes and associated circuitry. The refclk clock of 161.1328M for 100GE(or 174.6875M for OTU4) is necessary for our module.

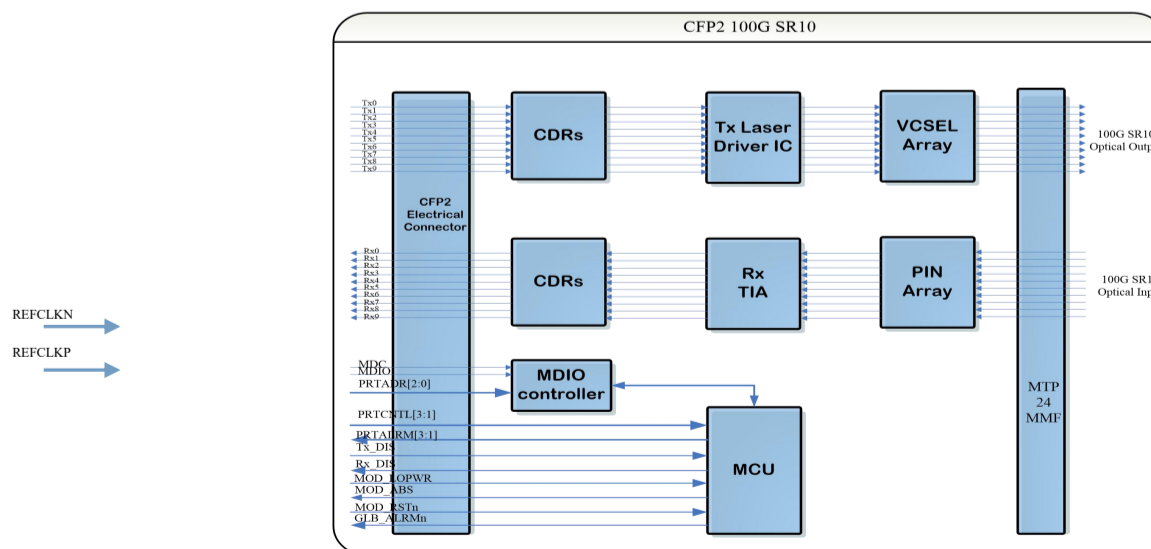

Figure1.Module Block Diagram



Absolute Maximum Ratings

Parameter	Symbol	Min	Max	Unit
Supply Voltage	Vcc	-0.5	3.6	V
Input Voltage	Vin	-0.3	Vcc+0.3	V
Storage Temperature	Tst	-40	85	°C
Humidity(non-condensing)	Rh	5	85	%

***Exceeding any one of these values may destroy the device immediately**

Recommended Operating Conditions

Parameter	Symbol	Min	Typical	Max	Unit
Supply Voltage	Vcc	3.13	3.3	3.47	V
Operating Case temperature	Tca	0		70	°C
Data Rate Per Lane	fd	-	10.3125	11.18	Gbps
Power Dissipation	Pm			8	W
Low Power Mode Dissipation	Plow			2	W
Aggregate Bit Rate	BRaggr		103.125	111.8	Gbps

Electrical Characteristics

Parameter	Symbol	Min	Typical	Max	Unit	Notes
Differential input impedance	Zin	90	100	110	ohm	
Differential Output impedance	Zout	90	100	110	ohm	
Differential input voltage amplitude	ΔV_{in}	120		820	mVp-p	
Differential output voltage amplitude	ΔV_{out}	300		820	mVp-p	
Input Logic Level High	VIH	2.0		VCC+0.3	V	3.3V LVCOMS
		0.84		1.2	V	1.2V LVCOMS
Input Logic Level Low	VIL	-0.3		0.8	V	3.3V LVCOMS
		-0.3		0.36	V	1.2V LVCOMS
Output Logic Level High	VOH	VCC-0.2		VCC	V	3.3V LVCOMS
		1.0		1.5	V	1.2V LVCOMS
Output Logic Level Low	VOL	0		0.2	V	3.3V LVCOMS
		-0.3		0.2	V	1.2V LVCOMS

Notes:

- Differential input voltage amplitude is measured between TxnP and TxnN.
- Differential output voltage amplitude is measured between RxnP and RxnN.



Optical Characteristics

Transmitter Optical Specifications (T = 25°C, VCC = 3.3V +/- 5%)

Parameter	Symbol	Min	Typical	Max	Unit
Average Optical Power(per channel)	P _{out}	-7.6	-1	+2.4	dBm
Average Optical Power(per channel) - Disabled	P _{off}			-30	dBm
Optical Return Loss Tolerance				12	dB
Extinction Ratio	ER	3			dB
Center Wavelength	λ_c	840	850	860	nm
RMS Spectral Width	λ		0.5	0.65	nm
Transmit OMA,per Lane	TX_OMA/lane	-5.6		3	dBm
Difference in launch power between any two lanes(OMA)				4	dB
Transmitter and dispersion penalty,each lane	TDP/lane			3.5	dB
Transmitter eye mask	Compliant to IEEE802.3ba eye mask specification				

Notes:

1. Average optical power is measured at the output of the modules optical interface.

Receiver Optical Specifications (T = 25°C, VCC = 3.3V +/- 5%)

Parameter	Symbol	Min	Typical	Max	Unit
Optical Power Sensitivity(per channel)	Pin min	-	-12	-9.9	dBm
Optical Power Saturation(per channel)	Pin max	+1	-	-	dBm
Stressed Receiver Sensitivity	PS	-	-	-5.4	dBm
Center Wavelength	λ_c	840	850	860	nm
RMS Spectral Width	λ		0.5	0.65	nm
Optical Return Loss	RI	12			dB
Damage Threshold		3.4			dBm
Optical modulation amplitude,each lane				3	dBm

Notes:

1. Optical power sensitivity is measured with BER@10⁻¹² at 10.3125Gbps per channel.



Pin Descriptions

Part A:Bottom Row Pin Function Definition

Pin	Symbol	Type	I/O	Description
1	GND			
2	TX9n	CML	I	Transmit data input
3	TX9p	CML	I	Transmit data input
4	GND			
5	TX8n	CML	I	Transmit data input
6	TX8p	CML	I	Transmit data input
7	GND			3.3V Module Supply Voltage Return Ground, can be separate or tied together with Signal Ground
8	3.3V_GND			
9	3.3V			
10	3.3V			
11	3.3V			
12	3.3V			
13	3.3V_GND			
14	3.3V_GND			
15	VND_IO_A		I/O	Module vendor I/O A.
16	VND_IO_B		I/O	Module vendor I/O B.
17	PRG_CNTL1	LVC MOS w/PU	I	Programmable Control 1 set via MDIO, MSA default: TRXIC_RSTn – TX & RX IC reset. "0" = reset, "1" or NC = enabled or not used
18	PRG_CNTL2	LVC MOS w/PU	I	Programmable Control 2 set via MDIO, MSA default: Hardware Interlock LSB, "00" ≤3W, "01" ≤6W, "10" ≤9W, "11" or NC ≤12W= not used
19	PRG_CNTL3	LVC MOS w/PU	I	Programmable Control 3 set via MDIO, MSA default: Hardware Interlock MSB, "00" ≤3W, "01" ≤6W, "10" ≤9W, "11" or NC ≤12W= not used
20	PRG_ALARM1	LVC MOS	O	Programmable Alarm 1 set via MDIO, MSA default:HIPWR_ON, "1" = Module high power up completed, "0" = Module not high powered up
21	PRG_ALARM2	LVC MOS	O	Programmable Alarm 2 set via MDIO,MSA default: MOD_READY,"1" = ready, "0" = not ready
22	PRG_ALARM3	LVC MOS	O	Programmable Alarm 3 set via MDIO, MSA default: MOD_FAULT, module fault detected, "1" = fault, "0" = no fault
23	GND	GND		
24	TX_DIS	LVC MOS w/PU	I	Transmitter Disable for all channels, "1" or NC = transmitter disabled, "0" = transmitter enabled
25	RX_LOS	LVC MOS	O	Receiver loss of optical signal on any channel, "1" = loss of signal, "0" = normal condition



Pin	Symbol	Type	I/O	Description
26	MOD_LOPWR	LVC MOS w/PU	I	Module low power mode. "1" or NC = module in low power (safe) mode, "0" = power-on enabled
27	MOD_ABS	GND	O	Module Absent. "1" or NC = Module absent, "0" = module present. Pull-up resistor on Host
28	MOD_RSTn	LVC MOS w/PD	I	Module Reset. "0" = reset the module, "1" or NC = module enabled, Pull Down resistor in module
29	GLB_ALRMn	LVC MOS	O	Global Alarm. "0" = alarm condition in any MDIO alarm register, "1" = no alarm .Pull-up resistor on Host
30	GND			
31	MDC	1.2V CMOS	I	Management data clock (electrical specs as per IEEE std802.3-2012)
32	MDIO	1.2V CMOS	I/O	Management Data I/O bi-directional data (electrical specs as IEEE std802.3-2012)
33	PRTADR0	1.2V CMOS	I	MDIO port address bit 0
34	PRTADR1	1.2V CMOS	I	MDIO port address bit 1
35	PRTADR2	1.2V CMOS	I	MDIO port address bit 2
36	VND_IO_C		I/O	Module vendor I/O C.
37	VND_IO_D		I/O	Module vendor I/O D.
38	VND_IO_E		I/O	Module vendor I/O E.
39	3.3V_GND			
40	3.3V_GND			
41	3.3V			3.3V Module power Supply
42	3.3V			
43	3.3V			
44	3.3V			
45	3.3V_GND			
46	GND			
47	RX9n	CML	O	Received data output
48	RX9p	CML	O	Received data output
49	GND			
50	RX8n	CML	O	Received data output
51	RX8p	CML	O	Received data output
52	GND			



Part B:Top Row Pin Function Definition

Pin	Symbol	Pin	Symbol
104	GND	78	REFCLKp
103	TX7n	77	GND
102	TX7p	76	RX7n
101	GND	75	RX7p
100	TX6n	74	GND
99	TX6p	73	RX6n
98	GND	72	RX6p
97	TX5n	71	GND
96	TX5p	70	RX5n
95	GND	69	RX5p
94	TX4n	68	GND
93	TX4p	67	RX4n
92	GND	66	RX4p
91	TX3n	65	GND
90	TX3p	64	RX3n
89	GND	63	RX3p
88	TX2n	62	GND
87	TX2p	61	RX2n
86	GND	60	RX2p
85	TX1n	59	GND
84	TX1p	58	RX1n
83	GND	57	RX1p
82	TX0n	56	GND
81	TX0p	55	RX0n
80	GND	54	RX0p
79	REFCLKn	53	GND

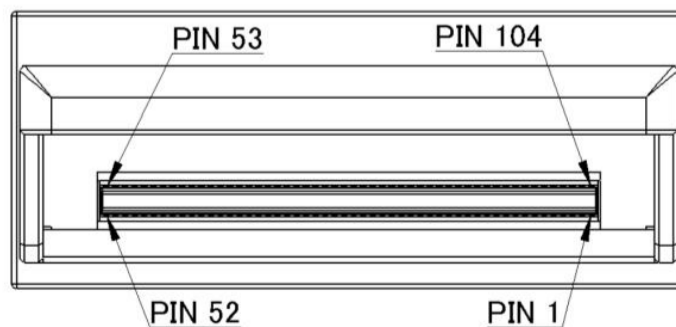

Figure 2. Pad Layout of the CFP2 module



CFP2 Optical Interface lanes and Assignment

Figure 3 shows the orientation of the multimode fiber facets of the optical connector.

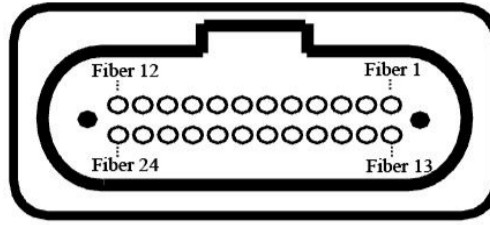
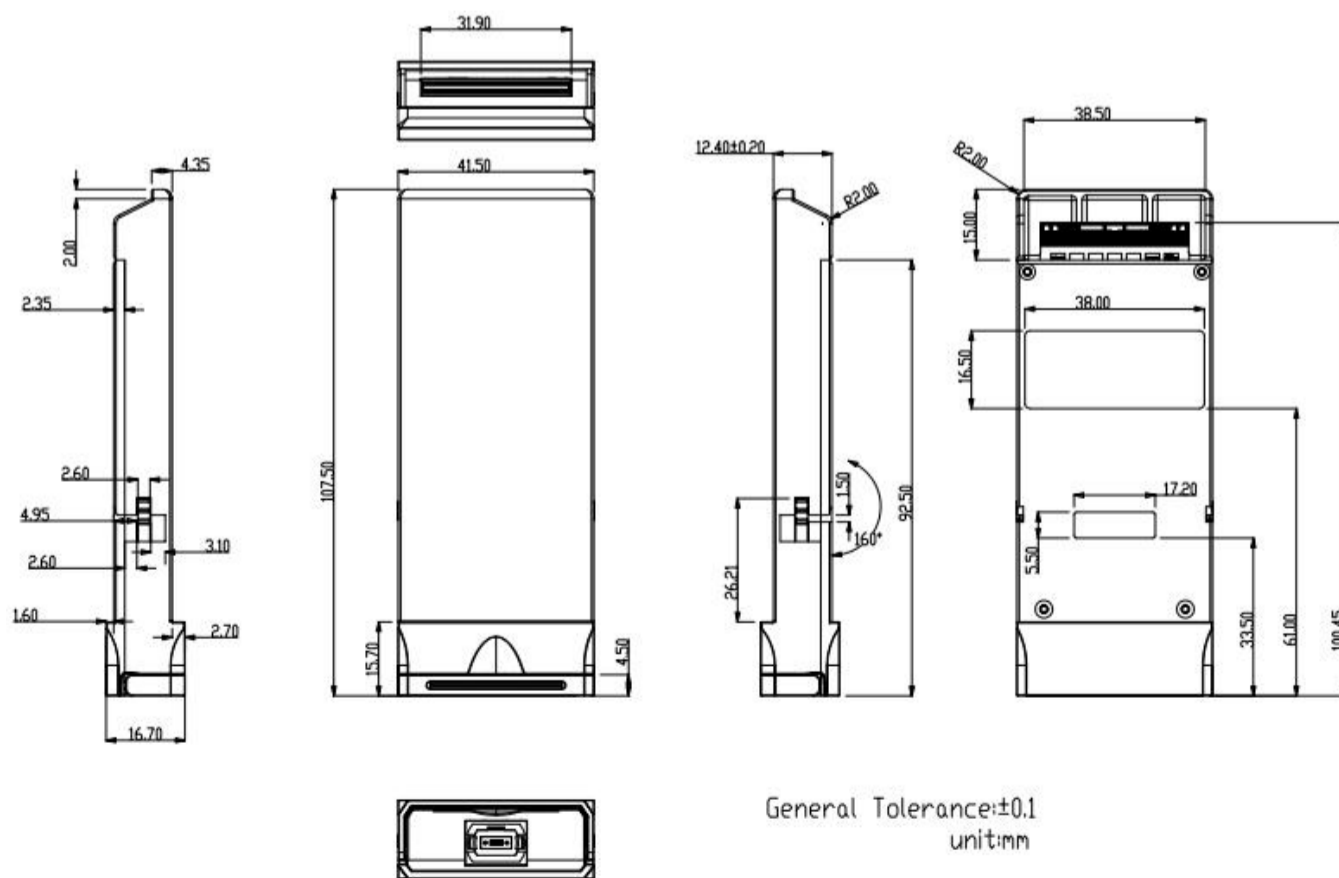

Figure 3. Outside view of the CFP2 module MPO receptacle

Lane Assignment

Fiber	Symbol	Corresponding Electrical pins	Fiber	Symbol	Corresponding Electrical pins
1	Unused		13	Unused	
2	RX0	54, 55	14	TX0	81, 82
3	RX1	57, 58	15	TX1	84, 85
4	RX2	60, 61	16	TX2	87, 88
5	RX3	63, 64	17	TX3	90, 91
6	RX4	66, 67	18	TX4	93, 94
7	RX5	69, 70	19	TX5	96, 97
8	RX6	72, 73	20	TX6	99, 100
9	RX7	75, 76	21	TX7	102, 103
10	RX8	50, 51	22	TX8	5, 6
11	RX9	47, 48	23	TX9	2, 3
12	Unused		24	Unused	

Mechanical Dimensions



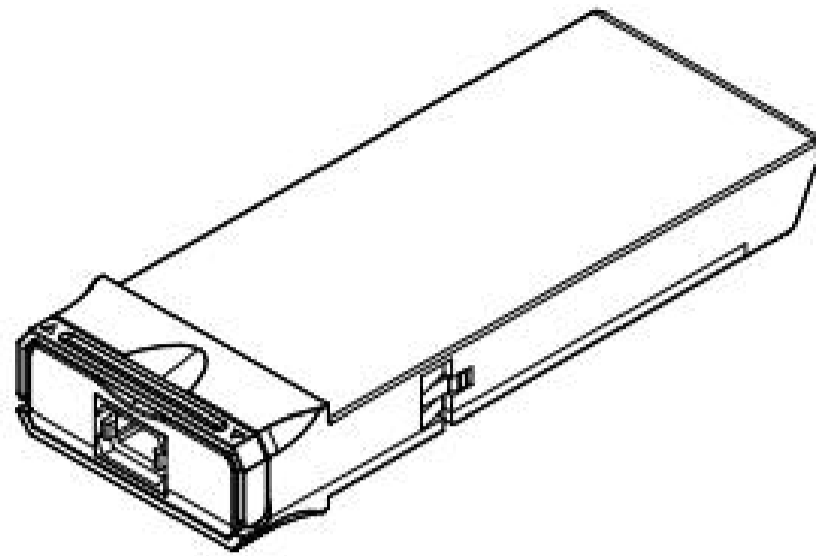

FiberStamp 100GBASE-SR10 CFP2

Ordering information

Part Number	Product Description
FSTC2-112G-SR10	100GE/OTU4 CFP2 SR10 850nm 400m Optical Transceiver Module

Important Notice

Performance figures, data and any illustrative material provided in this data sheet are typical and must be specifically confirmed in writing by FiberStamp before they become applicable to any particular order or contract. In accordance with the FiberStamp policy of continuous improvement specifications may change without notice.

The publication of information in this data sheet does not imply freedom from patent or other protective rights of FiberStamp or others. Further details are available from any FiberStamp sales representative.

