

# 100GE/OTU4 CFP2 LR4 1310nm 10km Optical Receiver Module

## Features

- Hot-pluggable CFP2 form factor
- 4 channels PIN ROSA without TOSA
- 4 parallel electrical serial interface and AC coupling of CML signals
- RX output CDR retiming
- Compliant with CFP2 MSA, IEEE 802.3ba 100GBASE-LR4 and OTN OTU4
- Data rate up to 111.8Gbps
- Power consumption < 3W
- Reach up to 10km over G.652 SMF
- Duplex LC receptacles
- MDIO management interface
- Operating case temperature range from 0°C to 70°C
- 3.3V power supply voltage
- RoHS compliant (lead free)



## Applications

- 100GbE IEEE 802.3ba 100GBASE-LR4
- OTN-OTU4
- Switch to switch interface or Switch to router interface

## Description

The FiberStamp 100GE/OTU4 CFP2 LR4 1310nm 10km Optical Receiver Module is a hot pluggable 100Gbps small-form-factor transceiver module .It is compliant with IEEE802.3ba and CFP MSA. The module is a multi-rate optical transceiver and intended to support Telecom and Datacom applications.

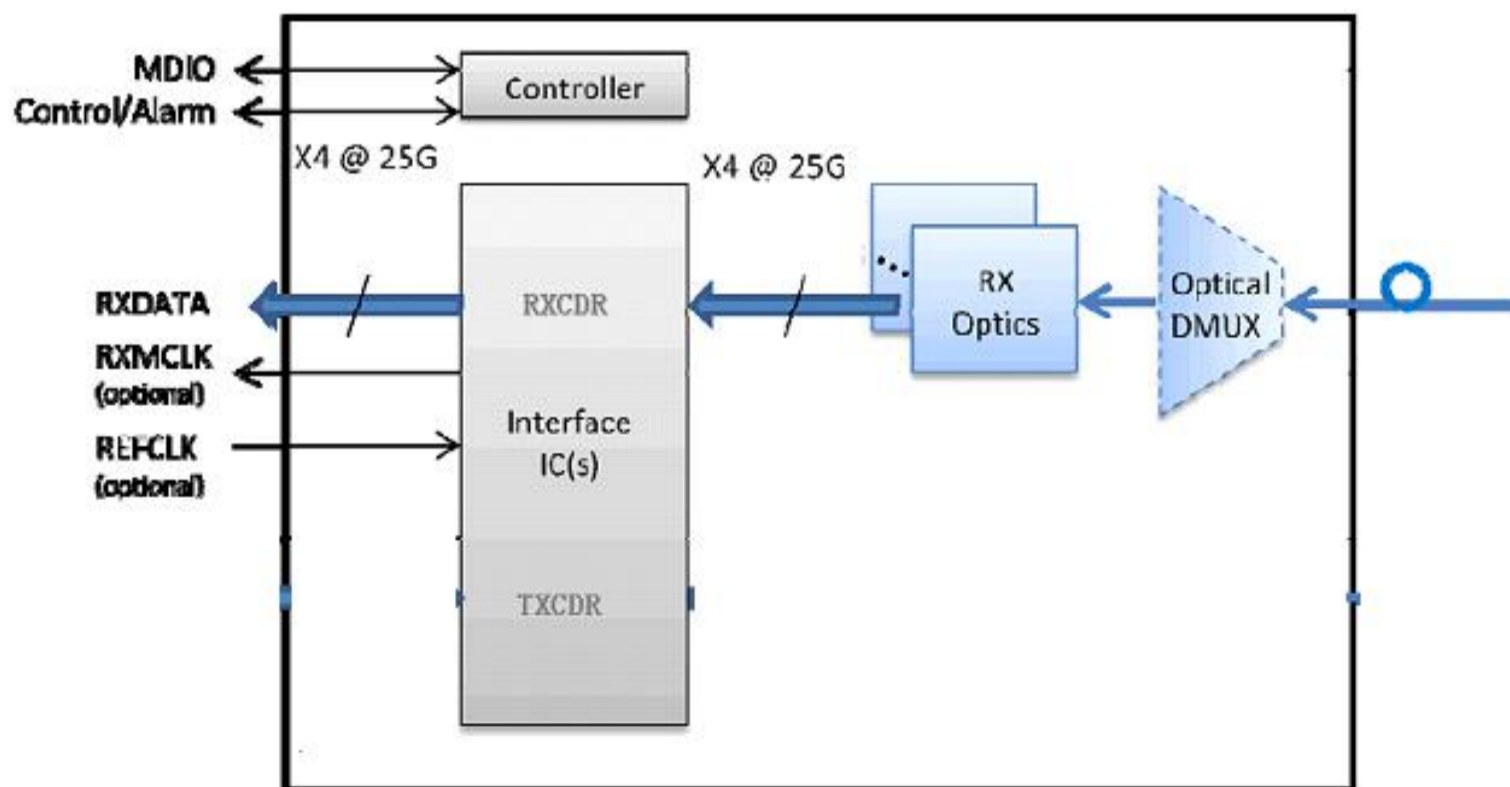

100GE CFP2 LR4 single receiver Module Block Diagram



**Absolute Maximum Ratings**

Parameter	Symbol	Unit	Min	Max
Supply Voltage	VCC3	V	-0.5	3.6
Storage Temperature	Ts	°C	-40	85
Operating Case Temperature	Tc	°C	0	70
Relative Humidity (Non condensation)	-	%	5	95

**Recommended Operating Conditions**

Parameter	Symbol	Unit	Min	Typ	Max
Operating Case Temperature	Tc	°C	0	-	70
Supply Voltage	VCC	V	3.13	3.3	3.47
Supply Current	ICC	A	-	-	0.9
Power Dissipation	-	W	-	-	3

**Optical Characteristics**

(Tested under recommended operating conditions, unless otherwise noted)

Parameter	Symbol	Unit	Value		
			Min	Typ	Max
<b>Optical Receiver Characteristics</b>					
Receiver Sensitivity in OMA for Each Lane(100GbE)	SOMA	dBm	-	-	-8.6
Receiver Sensitivity for Each Lane(OTU4)					-10.8
Los Assert		dBm			-12
Los De-assert		dBm	-19		
Los Hysteresis		dBm		1	

**Electrical Characteristics**

(Tested under recommended operating conditions, unless otherwise noted)

Parameter	Symbol	Unit	Min	Typ	Max	Note
<b>Receiver</b>						
Differential Data Output Swing	Vout,pp	mV	400	-	800	
Differential Signal Output Resistance		Ω	80	-	120	
Differential Signal Input Resistance		Ω	80	-	120	
LOS Fault	-	V	Vdd3-0.5	-	Vdd3	
LOS Normal	-	V	0	-	+ 0.5	1

Note1: Vdd3 is host +3.3V power supply.



**Low Speed Electrical Interface**

Parameter	Symbol	Unit	Min	Max	Note
Input High Voltage	VIH	V	2.0	Vcc3 + 0.3	
	VIL	V	-0.3	0.8	
Input Low Voltage	VOH	V	Vdd3-0.5	Vdd3 + 0.3	1
	VOL	V	0.0	0.4	
Input Leakage Current	Vih	V	Vdd3*0.7	Vdd3 + 0.5	1
	Vil	V	-0.3	Vdd3*0.3	
Output High Voltage (IOH = 100uA)	Voh	V	Vdd3-0.5	Vdd3 + 0.3	
	Vol	V	0.0	0.4	
Output low Voltage (IOH = 100uA)	IL	uA	-10	10	
Minimum Pulse Width of Control Pin Signal		KHz		400	

**1.2V LVCMOS Electrical Characteristics**

Input High Voltage	1.2VIH	V	0.84	1.5	
Input Low Voltage	1.2VIL	V	-0.3	0.36	
Input Leakage Current	1.2IIN	uA	-100	+ 100	
Output High Voltage	1.2V0H	V	1.0	1.5	
Output Low Voltage	1.2V0L	V	-0.3	0.2	
Output High Current	1.2IOH	mA		-4	
Output Low Current	1.2IOL	mA	+4		
Input Capacitance	Ci	pF		10	

**Hardware Control Pins**

The CFP2 Module support real-time control functions via hardware pins, listed in the following table:Hardware Control Pins

Pin#	Symbol	Description	I/O	Logic	H	L	Pull-up/down
17	PRG_CNTL1	Programmable Control 1 MSA Default:TRXIC_RSTn , TX&RX ICs reset, "0":reset;"1"	I	3.3V LVCMOS	per CFP MSA Management Interface Specification		Pull-Up Note1
18	PRG_CNTL2	Programmable Control 2 MSA Default : Hardware Interlock LSB	I	3.3V LVCMOS			Pull-Up Note1
19	PRG_CNTL3	Programmable Control 3 MSA Default:Hardware Interlock MSB	I	3.3V LVCMOS			Pull-Up Note1
26	MOD_LOPWR	Module Low Power Mode	I	3.3V LVCMOS	Low Power	Enable	Pull-Up Note1
28	MOD_RSTn	Module Reset(Invert)	I	3.3V LVCMOS	Enable	Reset	Pull-Down Note2
24	TX_DIS	Transmitter Disable	I	3.3V LVCMOS	Disable	Enable	Pull-Up Note1



**Notes:**

Pull-Up resistor (4.7KOhm to 10 KOhm) is located within the CFP2 module Note2: PuH-Down resistor (4.7KOhm to 10 kOhm) is located within the CFP2 module

**Hardware Alarm Pins**

The CFP Module supports alarm hardware pins listed in the following table: Hardware Alarm Pins

Pin#	Symbol	Description	I/O	Logic	H	L	Pull-up/down
20	PRG_ALARM1	Programmable Alarm 1 MSA Default:HIPWR_0N	O	3.3V LVCMOS			
21	PRG_ALARM3	Programmable Alarm 3 MSA Default: MOD_FAULT	O	3.3V LVCMOS			
22	MOD_ABS	Module Absent	O	3.3V LVCMOS			
27	RX_LOS	Receiver Loss of Signal	O	3.3V LVCMOS	Absent	Present	Pull-Down Note1
25	PRG_ALARM3	Receiver Loss of Signal	O	3.3V LVCMOS	Loss of Signal	OK	

**Notes:**

Pull-Down resistor (<100ohm) is located within the CFP module. Pull-up should be located on the host

**Management Interface Pins(MDIO)**

The CFP Module supports alarm, control and monitor functions via an MDIO bus. The CFP MDIO pins are listed in

Pin#	Symbol	Description	I/O	Logic	H	L	Pull-up/down
29	GLB_ALRMn	Global Alarm	I	3.3V LVCMOS	Ok	Alarm	
32	MDIO	Management Data Input Output Bi-Directional Data	I/O	1.2V LVCMOS			
31	MDC	MDIO Clock	I	1.2V LVCMOS			
33	PRTADR0	MDIO Physical Port address bit0	I	1.2V LVCMOS			
34	PRTADR1	MDIO Physical Port address bit1	I	1.2V LVCMOS			
35	PRTADR2	MDIO Physical Port address bit2	I	1.2V LVCMOS			



**Hardware Signaling Pin Timing Requirements**

Timing Parameters for CFP2 hardware Signal Pins are listed in the following table.

Parameter	Symbol	Min	Max	Unit	Notes&Conditions
Hardware MOD_LOPWR assert	t_MOD_LOPWR_assert		1	ms	Application Specific May depend on current state Condition when signal is applied .See Vendor Datasheet
Hardware MOD_LOPWR deassert	t_MOD_LOPWR_deassert			ms	Value is dependent upon module start-up time.Please See register " Maximum High-Power-up ime " in "CFP MSA Management Interface Specification"
Receiver Loss of Signal Assert Time	t_loss_assert		100	us	Maximum value designed to support telecom applications
Receiver Loss of Signal De-Assert Time	t_loss_deassert		100	us	Maximum value designed to support telecom applications
Global Alarm Assert Delay Time	GLB_ALRMn_assert		150	ms	This is a logical "OR" of Associated MDIO alarm& status registers.Please see MDIO document for further details
Global Alarm De-assert Delay Time	GLB_ALRMn_deassert		150	ms	This is a logical "OR" of Associated MDIO alarm& status registers.Please see MDIO document for further details
Management Interface Clock Period	t_prd	250		ns	MDC is 4MHz rate
Host MDIO t_setup	t_setup	10		ns	
Host MDIO t_hold	t_hold	10		ns	
CFP MDIO t_delay	t_delay	0	175	ns	
Initialization time from Reset	t_initialize		2.5	s	
Transmitter Disabled(TX_DIS_asserted)	t_deassert		100	us	Application Specific
Transmitter Enabled(TX_DIS_asserted)	t_assert		100	ms	Value is dependent upon module start-up time.Please See register "Maximum TX-Turn-on Time" in "CFP MSA Management Interface Specification"



PIN#	Name	I/O	Logic	Description	Notes
1	GND				
2	(TX_MCLKn)	O	CML	For optical waveform testing. Not for normal use	
3	(TX_MCLKp)	O	CML	For optical waveform testing. Not for normal use	
4	GND				
5	N.C.				
6	N.C.				
7	3.3V_GND			3.3V Module Supply Voltage Return Ground, can be separate, or tied together with Signal Ground	
8	3.3V_GND				
9	3.3V				
10	3.3V				
11	3.3V				
12	3.3V				
13	3.3V_GND				
14	3.3V_GND				
15	VND_IO_A	I/O		Module Vendor I/O A. Do Not Connect!	
16	VND_IO_B	I/O		Module Vendor I/O B. Do Not Connect!	
17	PRG_CNTL1	I	LVC MOS w/ PUR	Programmable Control 1 set over MDIO	
18	PRG_CNTL2	I	LVC MOS w/ PUR	Programmable Control 1 set over MDIO	
19	PRG_CNTL3	I	LVC MOS w/ PUR	Programmable Control 1 set over MDIO	
20	PRG_ALARM1	O	LVC MOS	Programmable Alarm 1 set over MDIO	
21	PRG_ALARM2	O	LVC MOS	Programmable Alarm 2 set over MDIO	
22	PRG_ALARM3	O	LVC MOS	Programmable Alarm 3 set over MDIO	
23	GND				



PIN#	Name	I/O	Logic	Description	Notes
24	TX_DIS	I	LVC MOS	Transmitter Disable for all lanes, "1" or NC = transmitter disabled, "0"= transmitter enabled	
25	RX_LOS	O	LVC MOS	Receiver Loss of Optical Signal, "1": low optical signal, "0": normal condition	
26	MOD_LOPWR	I	LVC MOS w/ PUR	Module Low Power Mode. "1" or NC: module in low power (safe) mode, "0": power-on enabled	
27	MOD_ABS	O		Module Absent. "1" or NC: module absent, "0": module present, Pull Up Resistor on Host	
28	MOD_RSTn	I	LVC MOS w/ PDR	Module Reset. "0" resets the module, "1" or NC = module enabled, Pull Down Resistor in Module	
29	GLB_ALRMn	O	LVC MOS	Global Alarm. "0": alarm condition in any MDIO Alarm register, "1": no alarm condition, Open Drain, Pull Up Resistor on Host	
30	GND				
31	MDC	I	1.2V CMOS	Management Data Clock (electrical specs as per 802.3ae and ba)	
32	MDIO	I/O	1.2V CMOS	Management Data I/O bi-directional data (electrical specs as per 802.3ae and ba)	
33	PRTADR0	I	1.2V CMOS	MDIO Physical Port address bit 1	
34	PRTADR1	I	1.2V CMOS	MDIO Physical Port address bit 2	
35	PRTADR2	I	1.2V CMOS	MDIO Physical Port address bit 3	
36	VND_IO_C	I/O		Module Vendor I/O C. Do Not Connect!	
37	VND_IO_D	I/O		Module Vendor I/O D. Do Not Connect!	
38	VND_IO_E	I/O		Module Vendor I/O E. Do Not Connect!	



PIN#	Name	I/O	Logic	Description	Notes
39	3.3V_GND				
40	3.3V_GND				
41	3.3V				
42	3.3V				
43	3.3V				
44	3.3V				
45	3.3V_GND				
30	GND				
31	MDC	I	1.2V CMOS	Management Data Clock (electrical specs as per 802.3ae and ba)	
32	MDIO	I/O	1.2V CMOS	Management Data I/O bi-directional data (electrical specs as per 802.3ae and ba)	
33	PRTADR0	I	1.2V CMOS	MDIO Physical Port address bit 1	
34	PRTADR1	I	1.2V CMOS	MDIO Physical Port address bit 2	
35	PRTADR2	I	1.2V CMOS	MDIO Physical Port address bit 3	
36	VND_IO_C	I/O		Module Vendor I/O C. Do Not Connect!	
37	VND_IO_D	I/O		Module Vendor I/O D. Do Not Connect!	
38	VND_IO_E	I/O		Module Vendor I/O E. Do Not Connect!	
39	3.3V_GND				
39	3.3V_GND				
40	3.3V_GND				
41	3.3V				
42	3.3V				
43	3.3V				
44	3.3V				
45	3.3V_GND				
46	3.3V_GND				
47	N.C.				
48	N.C.				





PIN#	Name	I/O	Logic	Description	Notes
49	GND				
50	(RX_MCLKn)	O	CML	For optical waveform testing. Not for normal use.	
51	(RX_MCLKp)	O	CML	For optical waveform testing. Not for normal use.	
52	GND				
53	GND				
54	N.C.				
55	N.C.				
56	GND				
57	RX0p	O	CML	Output Data	
58	RX0n	O	CML	Inverted Output Data	
59	GND				
60	RX1p	O	CML	Output Data	
61	RX1n	O	CML	Inverted Output Data	
62	GND				
63	N.C.				
64	N.C.				
65	GND				
59	GND				
60	RX1p	O	CML	Output Data	
61	RX1n	O	CML	Inverted Output Data	
62	GND				
63	N.C.				
64	N.C.				
65	GND				
70	RX2n	O	CML	Inverted Output Data	
71	GND				
72	RX3p	O	CML	Output Data	
73	RX3n	O	CML	Inverted Output Data	
74	GND				
75	N.C.				
76	N.C.				
77	GND				
78	NC				
79	NC				



PIN#	Name	I/O	Logic	Description	Notes
80	GND				
81	N.C.				
82	N.C.				
83	GND				
84	TX0p	I	CML	Input Data	NC
85	TX0n	I	CML	Inverted Input Data	NC
86	GND				
87	TX1p	I	CML	Input Data	NC
88	TX1n	I	CML	Inverted Input Data	NC
89	GND				
90	N.C.				
91	N.C.				
92	GND				
93	N.C.				
94	N.C.				
95	GND				
96	TX2p	I	CML	Input Data	NC
97	TX2n	I	CML	Inverted Input Data	NC
98	GND				
99	TX3p	I	CML	Input Data	NC
100	TX3n	I	CML	Inverted Input Data	NC
101	GND				
102	N.C.				
103	N.C.				
104	GND				

**Transmitter and Receiver Monitor Clock Characteristics**

		Min	Typ	Max	Unit	Notes
Impedance	Zd	80	100	120	Ω	
Frequency			3220		MHz	1/8 of Network lane rate
Output Differential Voltage	VDIFF	400		1200	mV	Peak to Peak Differential
Clock Duty Cycle		40		60	%	

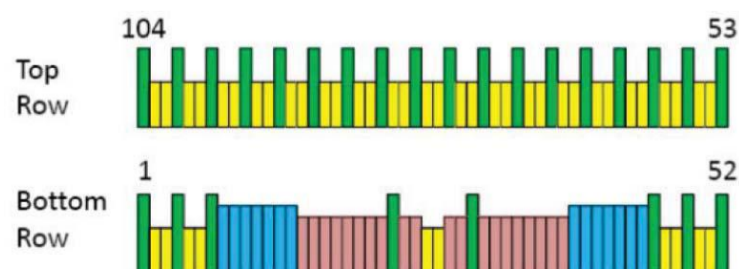

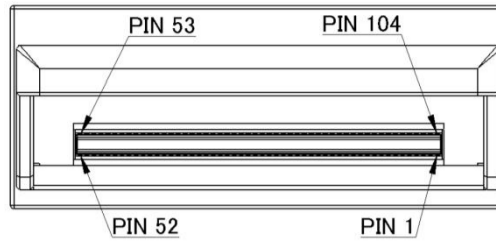

Pad Layout of the CFP2 module

Typical Application Circuit for Power Supply

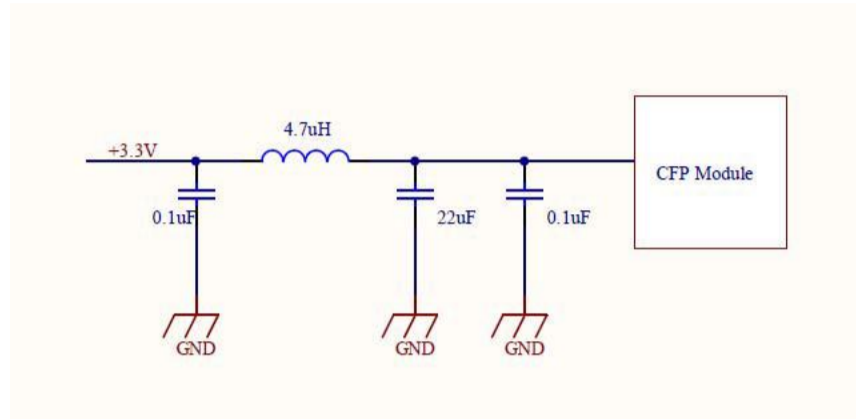

Mechanical Dimensions

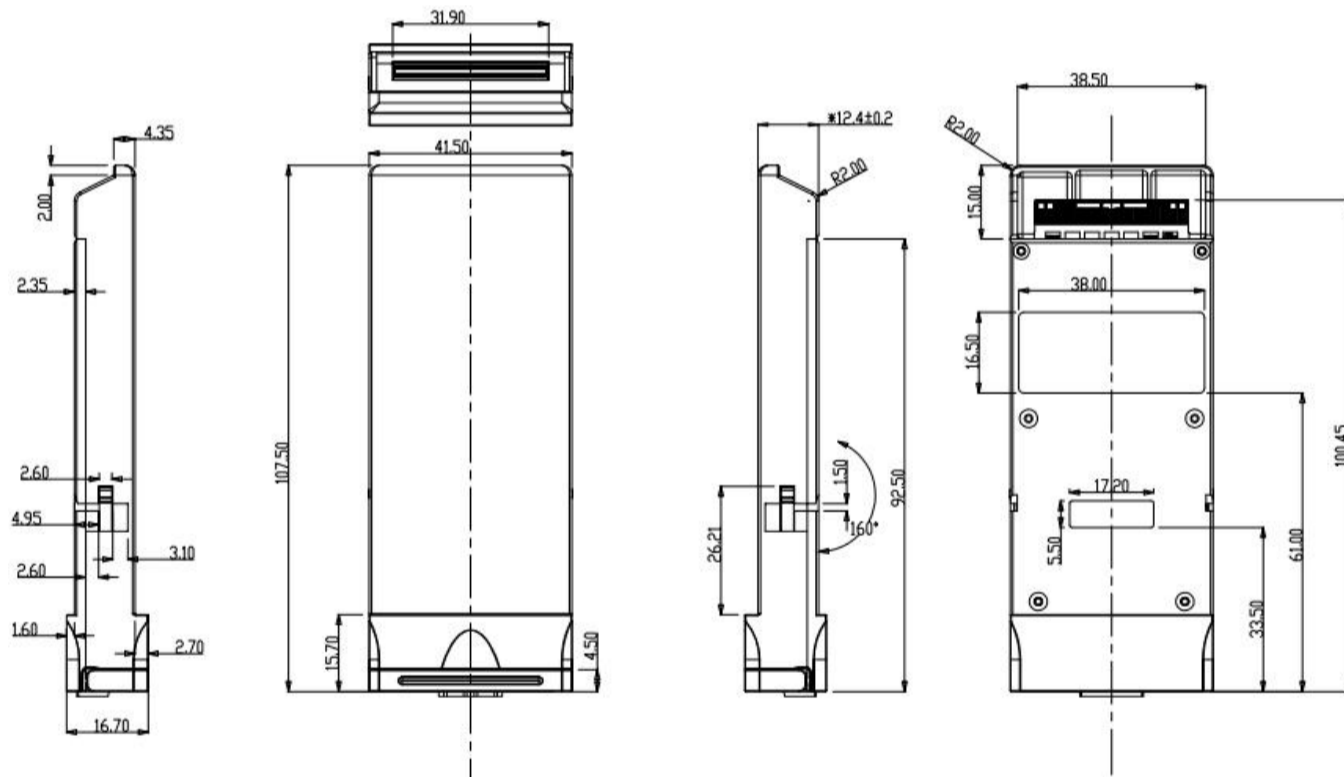

General Tolerance: ±0.1  
unit:mm

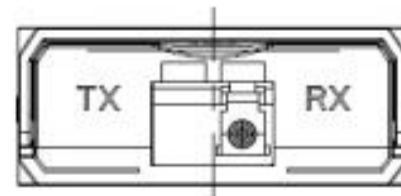
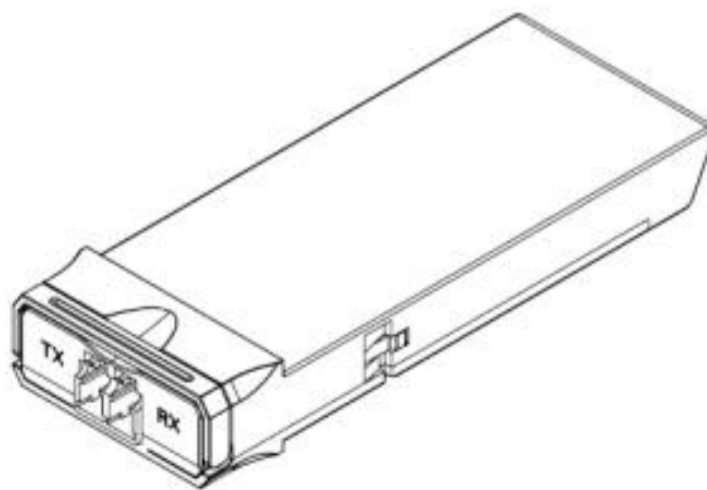

**Ordering information**

Part Number	Product Description
FSRC2-112G-LR4	100GE/OTU4 CFP2 LR4 1310nm 10km Optical Receiver Module

**Regulatory Compliance**

Feature	Test Method	Performance
Laser Eye Safety	FDA 21 CFR 1040.10 and 1040.11 IEC 60825-1: 1994+ A11: 1996+ A2: 2001 IEC 60825-2: 2004 + A1: 2006 EN 60825-1:1994+A1:2002+A2:2001 EN 60825-2: 2004	Compliant with Class 1 laser product
Electrostatic Discharge (ESD) to the Electrical Pins	MIL-STD-883E Method 3015.7 Human Body Model	Class 1 (>1.5kV)
Electrostatic Discharge (ESD) Immunity	IEC 61000-4-2: 2001	Class 2 (>4.0kV)
Electromagnetic Interference (EMI)	FCC Part 15 Subpart J Class B CISPR22:1997+A1:2000+A2:2002, Class B EN55022:1998+A1:2000+A2:2003, Class B	Compliant with standards

**Important Notice**

Performance figures, data and any illustrative material provided in this data sheet are typical and must be specifically confirmed in writing by FiberStamp before they become applicable to any particular order or contract. In accordance with the FiberStamp policy of continuous improvement specifications may change without notice.

The publication of information in this data sheet does not imply freedom from patent or other protective rights of FiberStamp or others. Further details are available from any FiberStamp sales representative.

