

100GE/OTU4 CFP SR10 850nm 400m Optical Transceiver Module

Features

- Hot-pluggable CFP form-factor
- 10 channels full-duplex transceiver module
- 10x 850nm VCSEL array and PIN photo-detector array
- Internal CDR circuits on both receiver and transmitter channels
- Compliant with CFP MSA, IEEE 802.3ba 100GBASE-SR10 and OTN OTU4
- Data rate up to 111.8Gbps
- Reach up to 300m (OM3) or 400m (OM4) over MMF
- Power consumption < 7W
- MPO24 receptacle
- MDIO digital diagnostic interface and control capabilities
- Operating case temperature range from 0°C to 70°C
- 3.3V power supply voltage
- RoHS compliant (lead free)



Applications

- 100GBE interconnects
- High-speed core router connections & Datacom/Telecom switch
- Data aggregation and backplane applications
- Proprietary protocol and density application

Description

The CFP optical transceiver module are a high performance, low power consumption, short reach(1m to 100m) interconnect solution supporting 100G Ethernet and Telecom. It is compliant with the CFP MSA and IEEE P802.3ba 100GBASE-SR10.

FiberStamp CFP SR10 modules offer 10 transmit and 10 receive asynchronous channels operating at up to 11.18Gbps per channel.

As shown in Figure 1, the transmitter side of the module consists of an array of VCSELS (Vertical Cavity Surface Emitting Lasers) and associated circuitry, which converts 10 parallel electrical data inputs to 10 parallel optical data output signals and also converts 10 parallel optical signals into 10 parallel electrical signals through an array of PIN photodiodes and associated circuitry.

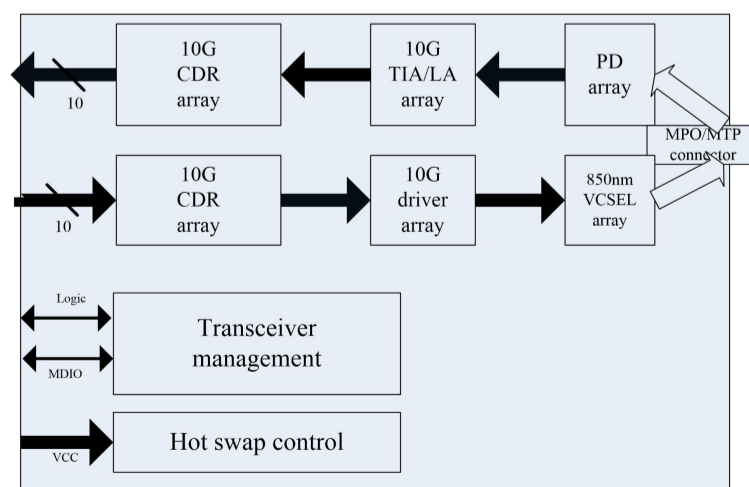

Figure1.Module Block Diagram



Absolute Maximum Ratings

Parameter	Symbol	Min	Max	Unit
Supply Voltage	Vcc	-0.5	3.6	V
Input Voltage	Vin	-0.3	Vcc+0.3	V
Storage Temperature	Tst	-40	85	°C
Humidity(non-condensing)	Rh	5	85	%

*Exceeding any one of these values may destroy the device immediately

Recommended Operating Conditions

Parameter	Symbol	Min	Typical	Max	Unit
Supply Voltage	Vcc	3.13	3.3	3.47	V
Operating Case temperature	Tca	0		70	°C
Data Rate Per Lane	fd	-	10.3125	11.18	Gbps
Power Dissipation	Pm			7	W
Low Power Mode Dissipation	Plow			2	W
Aggregate Bit Rate	BRaggr		103.125	111.8	Gbps

Electrical Characteristics

Parameter	Symbol	Min	Typical	Max	Unit	Notes
Differential input impedance	Zin	90	100	110	ohm	
Differential Output impedance	Zout	90	100	110	ohm	
Differential input voltage amplitude	ΔVin	120		820	mVp-p	
Differential output voltage amplitude	ΔVout	300		820	mVp-p	
Input Logic Level High	VIH	2.0		VCC+0.3	V	3.3V LVCOMS
		0.84		1.2	V	1.2V LVCOMS
Input Logic Level Low	VIL	-0.3		0.8	V	3.3V LVCOMS
		-0.3		0.36	V	1.2V LVCOMS
Output Logic Level High	VOH	VCC-0.2		VCC	V	3.3V LVCOMS
		1.0		1.5	V	1.2V LVCOMS
Output Logic Level Low	VOL	0		0.2	V	3.3V LVCOMS
		-0.3		0.2	V	1.2V LVCOMS

Notes:

1. Differential input voltage amplitude is measured between TxnP and TxnN.
2. Differential output voltage amplitude is measured between RxnP and RxnN.



Optical Characteristics

Transmitter Optical Specifications (T = 25°C, VCC =3.3V +/- 5%)

Parameter	Symbol	Min	Typical	Max	Unit
Average Optical Power(per channel)	Pout	-7.6	-1	+2.4	dBm
Average Optical Power(per channel) - Disabled	Poff			-30	dBm
Optical Return Loss Tolerance				12	dB
Extinction Ratio	ER	3			dB
Center Wavelength	λ_c	840	850	860	nm
RMS Spectral Width	λ		0.5	0.65	nm
Transmit OMA,per Lane	TX_OMA/lane	-5.6		3	dBm
Difference in launch power between any two lanes(OMA)				4	dB
Transmitter and dispersion penalty,each lane	TDP/lane			3.5	dB
Transmitter eye mask	Compliant to IEEE802.3ba eye mask specification				

Notes:

1. Average optical power is measured at the output of the modules optical interface.

Receiver Optical Specifications (T = 25°C, VCC =3.3V +/- 5%)

Parameter	Symbol	Min	Typical	Max	Unit
Optical Power Sensitivity(per channel)	Pin min	-	-12	-9.9	dBm
Optical Power Saturation(per channel)	Pin max	+2.4dBm	-	-	dBm
Stressed Receiver Sensitivity	PS	-	-	-5.4	dBm
Center Wavelength	λ_c	840	850	860	nm
RMS Spectral Width	λ		0.5	0.65	nm
Optical Return Loss	RI	12			dB
Damage Threshold		+3.4dBm			dBm
Optical modulation amplitude, each lane				3	dBm

Notes:

1. Optical power sensitivity is measured with BER@10⁻¹² at 10.3125Gbps per channel.



CFP module functional block diagram

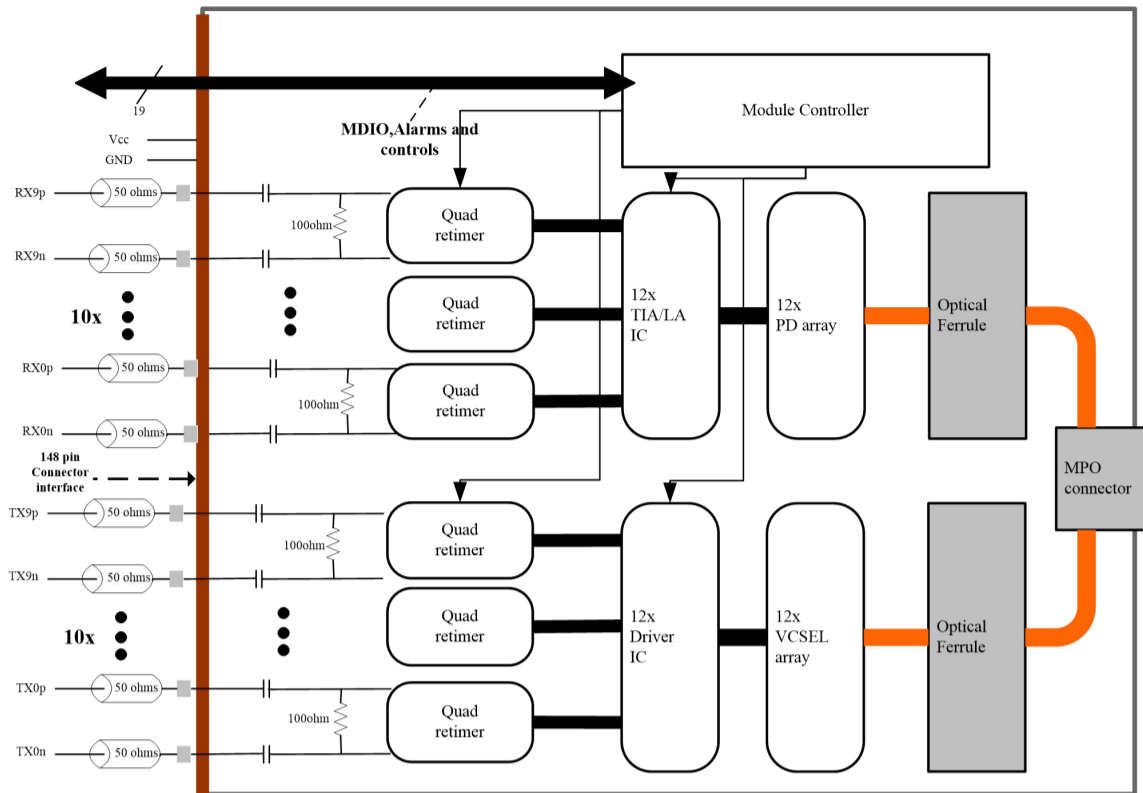

Figure2. CFP module functional block diagram

Pin Descriptions

Part A: Bottom Row Pin Function Definition

Pin	Symbol	Type	I/O	Description
1	3.3V_GND	GND		3.3V Module Supply Voltage Return Ground, can be separate or tied together with Signal Ground
2	3.3V_GND	GND		
3	3.3V_GND	GND		
4	3.3V_GND	GND		
5	3.3V_GND	GND		
6	3.3V	VCC		3.3V Module Supply
7	3.3V	VCC		
8	3.3V	VCC		
9	3.3V	VCC		
10	3.3V	VCC		
11	3.3V	VCC		
12	3.3V	VCC		
13	3.3V	VCC		
14	3.3V	VCC		
15	3.3V	VCC		
16	3.3V_GND	GND		
17	3.3V_GND	GND		
18	3.3V_GND	GND		
19	3.3V_GND	GND		



Pin	Symbol	Type	I/O	Description
20	3.3V_GND	GND		
21	NC		I/O	FiberStamp internal, do not connect
22	NC		I/O	FiberStamp internal, do not connect
23	GND	GND		
24	(TX_MCLKn)	CML	O	CML For optical waveform testing. Not used.
25	(TX_MCLKp)	CML	O	CML For optical waveform testing. Not used.
26	GND	GND		
27	NC		I/O	FiberStamp internal, do not connect
28	NC		I/O	FiberStamp internal, do not connect
29	NC		I/O	FiberStamp internal, do not connect
30	PRG_CNTL1	LVC MOS w/PU	I	Programmable Control 1 set via MDIO, MSA default: TRXIC_RSTn – TX & RX IC reset. "0" = reset, "1" or NC = enabled or not used
31	PRG_CNTL2	LVC MOS w/PU	I	Programmable Control 2 set via MDIO, MSA default: Hardware power Interlock LSB, "00" = <8W, "01" = <16W, "10" < 24W, "11" or NC = >24W or not used
32	PRG_CNTL3	LVC MOS w/PU	I	Programmable Control 3 set via MDIO, MSA default: Hardware power Interlock MSB, "00" = <8W, "01" = <16W, "10" < 24W, "11" or NC = >24W or not used
33	PRG_ALRM1	LVC MOS	O	Programmable Alarm 1 set via MDIO, Reflex default: HIPWR_ON, Module power on indicator. "1" = Module high power up completed, "0" = Module not high powered up
34	PRG_ALRM2	LVC MOS	O	Programmable Alarm 2 set via MDIO, Reflex default: MOD_READY, module initialization complete, "1" = complete, "0" = not complete
35	PRG_ALRM3	LVC MOS	O	Programmable Alarm 3 set via MDIO, Reflex default: MOD_FAULT, module fault detected, "1" = fault, "0" = no fault
36	TX_DIS	LVC MOS w/PU	I	Transmitter Disable for all channels, "1" or NC = transmitter disabled, "0" = transmitter enabled
37	MOD_LOPWR	LVC MOS w/PU	I	Module low power mode. "1" or NC = module in low power (safe) mode, "0" = power-on enabled
38	MOD_ABS	GND	O	Module Absent. "1" or NC = Module absent, "0" = module present. Pull-up resistor on Host
39	MOD_RSTn	LVC MOS w/PD	I	Module Reset. "0" = reset the module, "1" or NC = module enabled, Pull Down resistor in module
40	RX_LOS	LVC MOS	O	Receiver loss of optical signal on any channel, "1" = loss of signal, "0" = normal condition
41	GLB_ALRMn	LVC MOS	O	Global Alarm. "0" = alarm condition in any MDIO alarm register, "1" = no alarm
42	PRTADR4	1.2V CMOS	I	MDIO port address bit 4
43	PRTADR3	1.2V CMOS	I	MDIO port address bit 3



Pin	Symbol	Type	I/O	Description
44	PRTADR2	1.2V CMOS	I	MDIO port address bit 2
45	PRTADR1	1.2V CMOS	I	MDIO port address bit 1
46	PRTADR0	1.2V CMOS	I	MDIO port address bit 0
47	MDIO	1.2V CMOS	I/O	Management Data I/O bi-directional data (electrical specs as per 802.3ae)
48	MDC	1.2V CMOS	I	Management data clock (electrical specs as per 802.3ae)
49	GND	GND		
50	NC		I/O	FiberStamp internal, do not connect
51	NC		I/O	FiberStamp internal, do not connect
52	GND	GND		
53	NC		I/O	FiberStamp internal, do not connect
54	NC		I/O	FiberStamp internal, do not connect
55	3.3V_GND	GND		3.3V Module Supply Voltage Return Ground, can be separate or tied together with Signal Ground
56	3.3V_GND	GND		
57	3.3V_GND	GND		
58	3.3V_GND	GND		
59	3.3V_GND	GND		
60	3.3V	VCC		3.3V Module Supply
61	3.3V	VCC		
62	3.3V	VCC		
63	3.3V	VCC		
64	3.3V	VCC		
65	3.3V	VCC		
66	3.3V	VCC		
67	3.3V	VCC		
68	3.3V	VCC		
69	3.3V	VCC		
70	3.3V_GND	GND		
71	3.3V_GND	GND		
72	3.3V_GND	GND		
73	3.3V_GND	GND		
74	3.3V_GND	GND		



Part b:Top Row Pin Function Definition

Pin	Symbol	Pin	Symbol
148	GND	111	GND
147	Not used	110	Not used
146	Not used	109	Not used
145	GND	108	GND
144	Not used	107	RX9n
143	Not used	106	RX9p
142	GND	105	GND
141	TX9n	104	RX8n
140	TX9p	103	RX8p
139	GND	102	GND
138	TX8n	101	RX7n
137	TX8p	100	RX7p
136	GND	99	GND
135	TX7n	98	RX6n
134	TX7p	97	RX6p
133	GND	96	GND
132	TX6n	95	RX5n
131	TX6p	94	RX5p
130	GND	93	GND
129	TX5n	92	RX4n
128	TX5p	91	RX4p
127	GND	90	GND
126	TX4n	89	RX3n
125	TX4p	88	RX3p
124	GND	87	GND
123	TX3n	86	RX2n
122	TX3p	85	RX2p
121	GND	84	GND
120	TX2n	83	RX1n
119	TX2p	82	RX1p
118	GND	81	GND
117	TX1n	80	RX0n
116	TX1p	79	RX0p
115	GND	78	GND



Pin	Symbol	Pin	Symbol
114	TX0n	77	Not used
113	TX0p	76	Not used
112	GND	75	GND

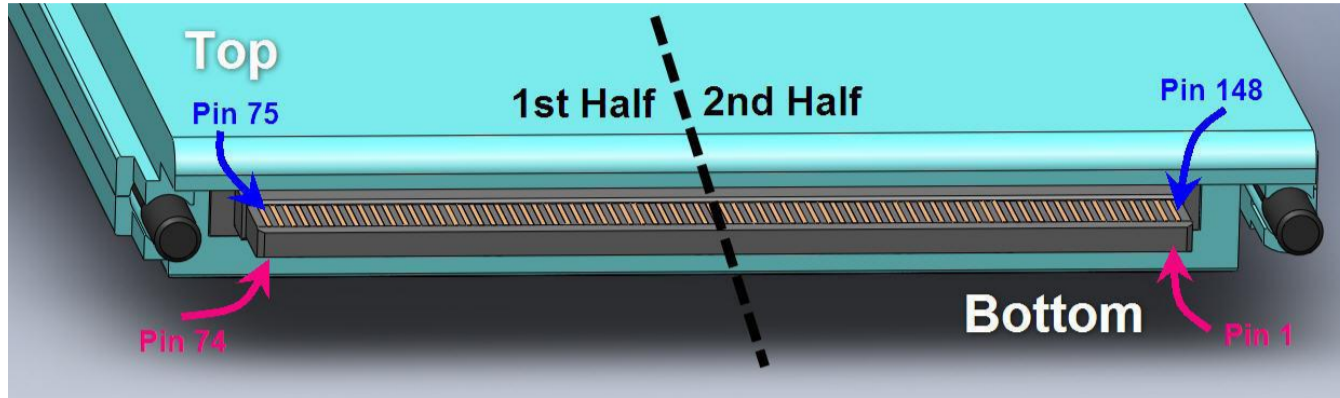

Figure3.Pad Layout of the CFP module

CFP Optical Interface lanes and Assignment

Figure 3 shows the orientation of the multimode fiber facets of the optical connector.

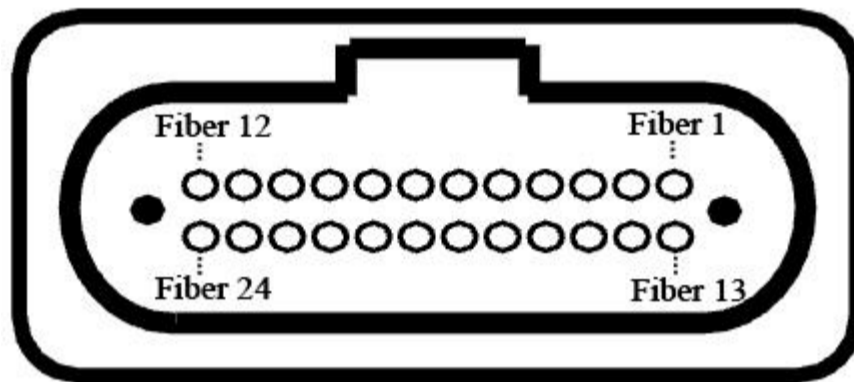

Figure4. Outside view of the CFP module MPO receptacle

Lane Assignment

Fiber	Symbol	Corresponding Electrical pins	Fiber	Symbol	Corresponding Electrical pins
1	Unused		13	Unused	
2	RX0	79,80	14	TX0	113,114
3	RX1	82,83	15	TX1	116,117
4	RX2	85,86	16	TX2	119,120
5	RX3	88,89	17	TX3	122,123
6	RX4	91,92	18	TX4	125,126
7	RX5	94,95	19	TX5	128,129
8	RX6	97,98	20	TX6	131,132
9	RX7	100,101	21	TX7	134,135
10	RX8	103,104	22	TX8	137,138
11	RX9	106,107	23	TX9	140,141
12	Unused		24	Unused	



Mechanical Dimensions

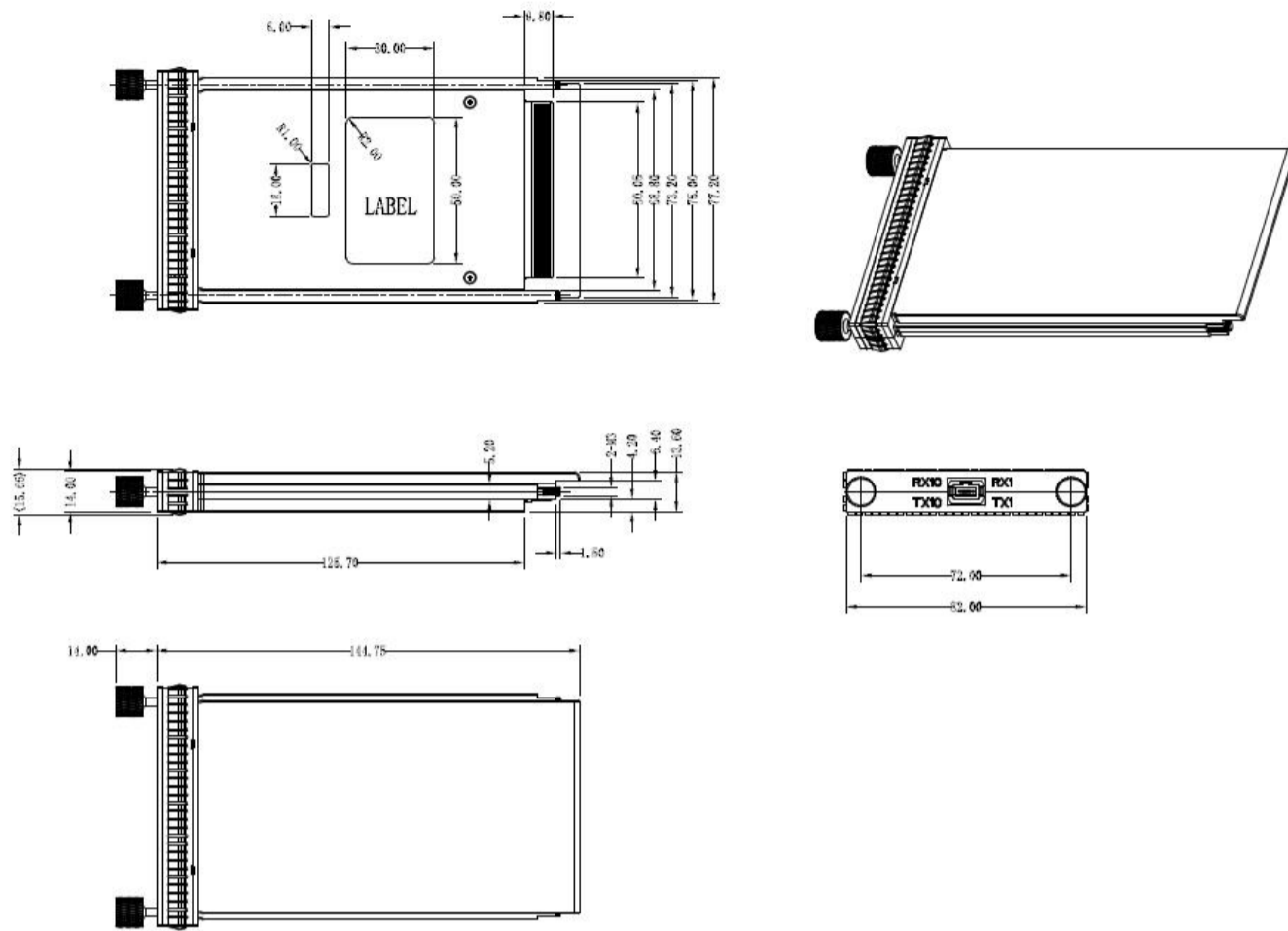

Figure 5. Mechanical Specifications

Ordering information

Part Number	Product Description
FSTC-112G-SR10	100GE/OTU4 CFP SR10 850nm 400m Optical Transceiver Module

Important Notice

Performance figures, data and any illustrative material provided in this data sheet are typical and must be specifically confirmed in writing by FiberStamp before they become applicable to any particular order or contract. In accordance with the FiberStamp policy of continuous improvement specifications may change without notice.

The publication of information in this data sheet does not imply freedom from patent or other protective rights of FiberStamp or others. Further details are available from any FiberStamp sales representative.

