

100GBASE-LR4 and OTU4 10km QSFP28 Transceiver (C-temp)

Features

- Hot-pluggable QSFP28 form-factor
- 4 channels full-duplex transceiver module
- 4x cooled LAN-WDM DML transmitter and PIN ROSA
- Internal CDR circuits on both receiver and transmitter channels
- Compliant with QSFP28 MSA and IEEE 802.3ba 100GBASE-LR4
- Compliant with OTN OTU4
- Data rate up to 111.8Gbps
- Reach up to 10km over G.652 SMF
- Power consumption < 3.5W
- Duplex LC receptacles
- Operating case temperature range from 0°C to 70°C
- 3.3V power supply voltage
- RoHS compliant (lead free)



Applications

- Data Center Network
- Optical Transport Network (OTN)

Module Block Diagram

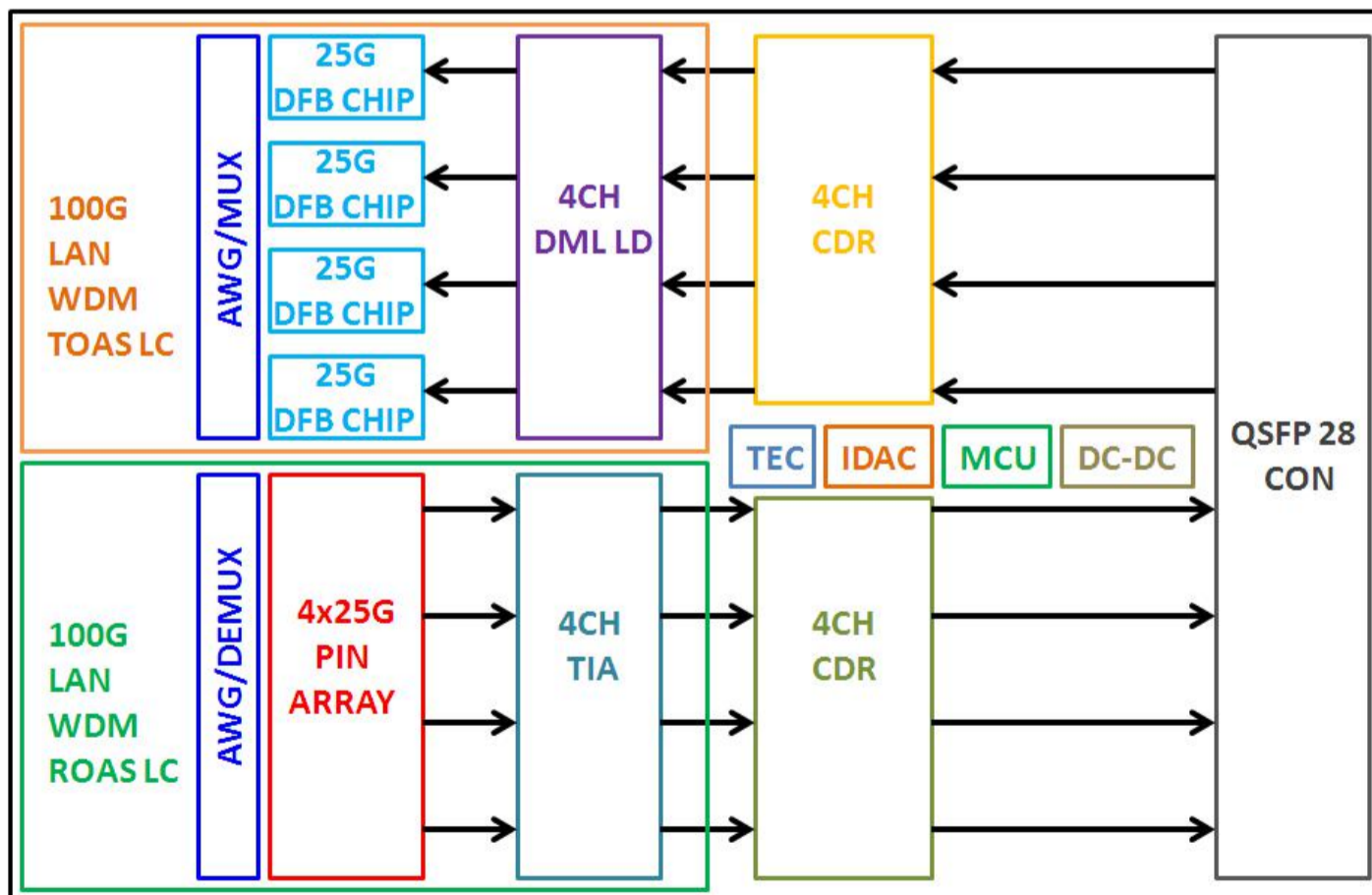

Ordering information

Part Number	Product Description
FST-112G-LR4	100GBASE-LR4 and OTU4 10km QSFP28 Transceiver (C-temp)



Absolute Maximum Ratings

Parameter	Symbol	Min	Max	Unit
Supply Voltage	Vcc	-0.3	3.6	V
Input Voltage	Vin	-0.3	Vcc+0.3	V
Storage Temperature	Tst	-20	85	°C
Case Operating Temperature	Top	0	70	°C
Humidity(non-condensing)	Rh	5	85	%
Damage Threshold, each Lane	TH	5.5		dBm

Recommended Operating Conditions

Parameter	Symbol	Min	Typical	Max	Unit
Supply Voltage	Vcc	3.13	3.3	3.47	V
Operating Case temperature	Tca	0		70	°C
Data Rate Per Lane	fd			28	Gbps
Humidity	Rh	5		85	%
Power Dissipation	P			3.5	W
Link Distance with G.652	D	0.002		10	km

Electrical Specifications

Parameter	Symbol	Min	Typical	Max	Unit
Power Consumption	P			3.5	W
Supply Current	Icc			1.06	A
Transceiver Power-on Initialization Time				2000	ms
Transmitter(each Lane)					
Single-ended Input Voltage Tolerance		-0.3		4.0	V
AC Common Mode Input Voltage Tolerance		15			mV
Differential Input Voltage		50			mVpp
Differential Input Voltage Swing	Vin			900	mVpp
Differential Input Impedance	Zin	90	100	110	Ohm
Receiver(each Lane)					
Single-ended Output Voltage		-0.3		4.0	V
AC Common Mode Output Voltage				7.5	mV
Differential Output Voltage Swing	Vout	300		850	mVpp
Differential Output Impedance	Zout	90	100	110	Ohm

Notes:

Power-on Initialization Time is the time from when the power supply voltages reach and remain above the minimum recommended operating supply voltages to the time when the module is fully functional.



Optical Characteristics

QSFP28 100GBASE-LR4						
Parameter	Symbol	Min	Typical	Max	Unit	Notes
Lane Wavelength	L0	1294.53	1295.56	1296.59	nm	
	L1	1299.02	1300.05	1301.09	nm	
	L2	1303.54	1304.58	1305.63	nm	
	L3	1308.09	1309.14	1310.19	nm	
Transmitter						
SMSR	SMSR	30			dB	
Total Average Launch Power	PT			10.5	dBm	
Average Launch Power, each Lane	PAVG	-4.3		4.5	dBm	
OMA, each Lane	POMA	-1.3		4.5	dBm	1
Difference in Launch Power between any Two Lanes (OMA)	Ptx,diff			5	dB	
Launch Power in OMA minus Transmitter and Dispersion Penalty (TDP), each Lane		-2.3			dBm	
TDP, each Lane	TDP			2.2	dB	
Extinction Ratio	ER	4			dB	
RIN20OMA	RIN			-130	dB/Hz	
Optical Return Loss Tolerance	TOL			20	dB	
Transmitter Reflectance	RT			-12	dB	
Eye Mask coordinates: X1, X2, X3, Y1, Y2, Y3			{0.25, 0.4, 0.45, 0.25, 0.28, 0.4}			2
Average Launch Power OFF Transmitter, each Lane	Poff			-30	dBm	
Receiver						
Damage Threshold, each Lane	THd	5.5			dBm	3
Total Average Receive Power				10.5	dBm	
Average Receive Power, each Lane		-10.6		4.5	dBm	
Receive Power (OMA), each Lane				4.5	dBm	
Receiver Sensitivity (OMA), each Lane	SEN			-8.6	dBm	
Stressed Receiver Sensitivity (OMA), each Lane				-6.8	dBm	4



QSFP28 100GBASE-LR4						
Parameter	Symbol	Min	Typical	Max	Unit	Notes
Difference in Receive Power between any Two Lanes (OMA)	Prx,diff			5.5	dB	
LOS Assert	LOSA		-18		dBm	
LOS Deassert	LOSD		-15		dBm	
LOS Hysteresis	LOSH	0.5			dB	
Receiver Electrical 3 dB upper Cutoff Frequency, each Lane	Fc			31	GHz	
Conditions of Stress Receiver Sensitivity Test (Note 5)						
Vertical Eye Closure Penalty, each Lane			1.8		dB	5
Stressed Eye J2 Jitter, each Lane			0.3		UI	
Stressed Eye J9 Jitter, each Lane			0.47		UI	

Notes:

1. Even if the TDP < 1 dB, the OMA min must exceed the minimum value specified here.
2. See Figure 4 below.
3. The receiver shall be able to tolerate, without damage, continuous exposure to a modulated optical input signal having this power level on one lane. The receiver does not have to operate correctly at this input power.
4. Measured with conformance test signal at receiver input for BER = 1x10-12.
5. Vertical eye closure penalty and stressed eye jitter are test conditions for measuring stressed receiver sensitivity. They are not characteristics of the receiver.

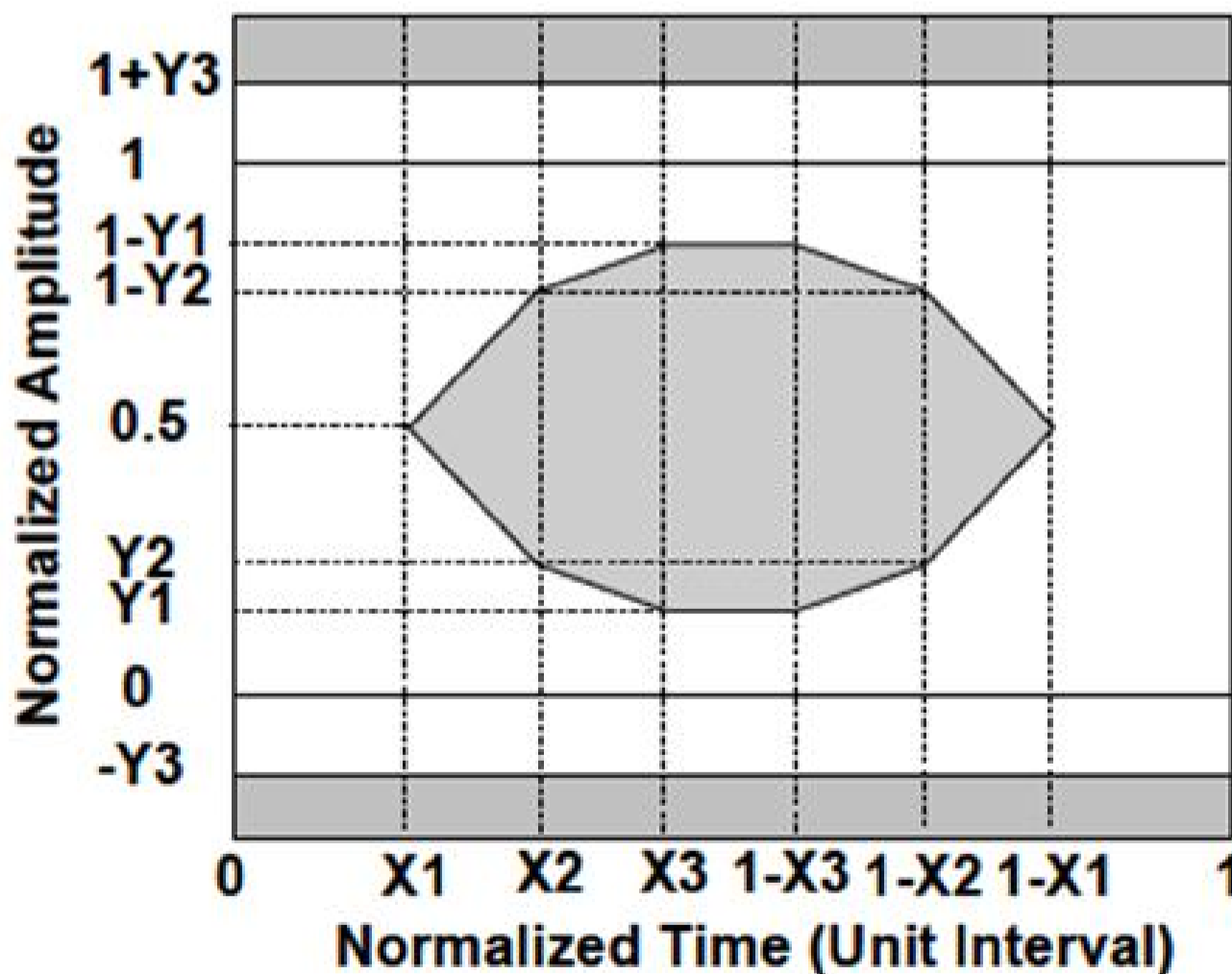

OTU4 411-9D1F Operation

QSFP28 100GBASE-LR4						
Parameter	Symbol	Min	Typical	Max	Unit	Notes
Signaling Speed per Channel			27.9525+/-20 ppm		GBd	1
Lane Wavelength	L0	1294.53	1295.56	1296.59	nm	
	L1	1299.02	1300.05	1301.09	nm	
	L2	1303.54	1304.58	1305.63	nm	
	L3	1308.09	1309.14	1310.19	nm	
Transmitter						
Total Average Launch Power	PT			10	dBm	
Average Launch Power, each Lane	PAVG	-0.6		4.0	dBm	
Difference in Launch Power between any Two Lanes (OMA)	Ptx,diff			5	dB	
Extinction Ratio	ER	4		6.5	dB	
Optical Return Loss Tolerance	TOL			20	dB	
Transmitter Reflectance	RT			-12	dB	
Eye Mask coordinates: X1, X2, X3, Y1, Y2, Y3		{0.25, 0.4, 0.45, 0.25, 0.28, 0.4}				2
Average Launch Power OFF Transmitter, each Lane	Poff			-30	dBm	
Receiver						
Signaling Speed per Channel			27.9525+/-20 ppm		GBd	3
Total Average Receive Power				10	dBm	
Average Receive Power, each Lane		-6.9		4.0	dBm	4
Optical Path Penalty	OPP			1.5	dBm	
Equivalent Sensitivity, each Lane	SEN			-8.4	dBm	4
LOS Assert	LOSA			-11.6	dBm	
LOS Deassert	LOSD			-13.6	dBm	
LOS Hysteresis	LOSH	0.5			dB	

Notes:

1. Transmitter consists of 4 lasers operating at 27.95G/s each.
2. Hit ratio 5×10^{-5} .
3. Receiver consists of 4 photodetectors operating at 27.95Gb/s each.
4. Specified at a BER of 10^{-6} (Pre-FEC),per ITU-T G.sup39.



Mechanical Dimensions

