

QSFP28 100GBASE-ER4 Lite 1310nm 30km/40km SMF LC Optical Transceiver Module

FST-100G-ER4L

Features

- 4 channels full-duplex transceiver modules
- Supports data rate up to 103.1Gb/s
- Supports QSFP28 4WDM 40km MSA\100GBASE-ER4 Lite
- 4 x 25Gb/s DFB-based LAN-WDM Cooling transmitter
- 4 channels APD ROSA
- Internal CDR circuits on both receiver and transmitter channels
- Low power consumption<3.8W
- Hot Pluggable QSFP form factor
- Up to 30kmreachfor G.652 SMF without FEC
- Up to 40kmreach for G.652 SMF with FEC
- Duplex LC receptacles
- Operating case temperature 0°C to +70°C
- 3.3V power supply voltage
- RoHS 6 compliant(lead free)



Applications

- IEEE 802.3ba 100GBASE ER4 Links
- Client-side 100G interconnections

Description

This product is a 100Gb/s transceiver module designed for optical communication applications compliant to QSFP28 4WDM 40km MSA/100GBASE-ER4 Lite standard. The module converts 4 input channels of 25Gb/s electrical data to 4 channels of LAN WDM optical signals and then multiplexes them into a single channel for 100Gb/s optical transmission. Reversely on the receiver side, the module de-multiplexes a 100Gb/s optical input into 4 channels of LAN WDM optical signals and then converts them to 4 output channels of electrical data.

The central wavelengths of the 4 LAN WDM channels are 1295.56,1300.05,1304.58 and 1309.14 nm as members of the LAN WDM wavelength grid defined in IEEE 802.3ba. The high performance cooled LAN WDM DFB transmitters and high sensitivity APD receivers provide superior performance for 100Gigabit Ethernet applications up to 30km links without FEC and up to 40km links with FEC interconnections.

The product is designed with form factor, optical/electrical connection and digital diagnostic interface according to the QSFP+ Multi-Source Agreement (MSA). It has been designed to meet the harshest external operating conditions including temperature, humidity and EMI interference.



QSFP28 ER4/4WDM 40km CIRCUIT STRUCTURE

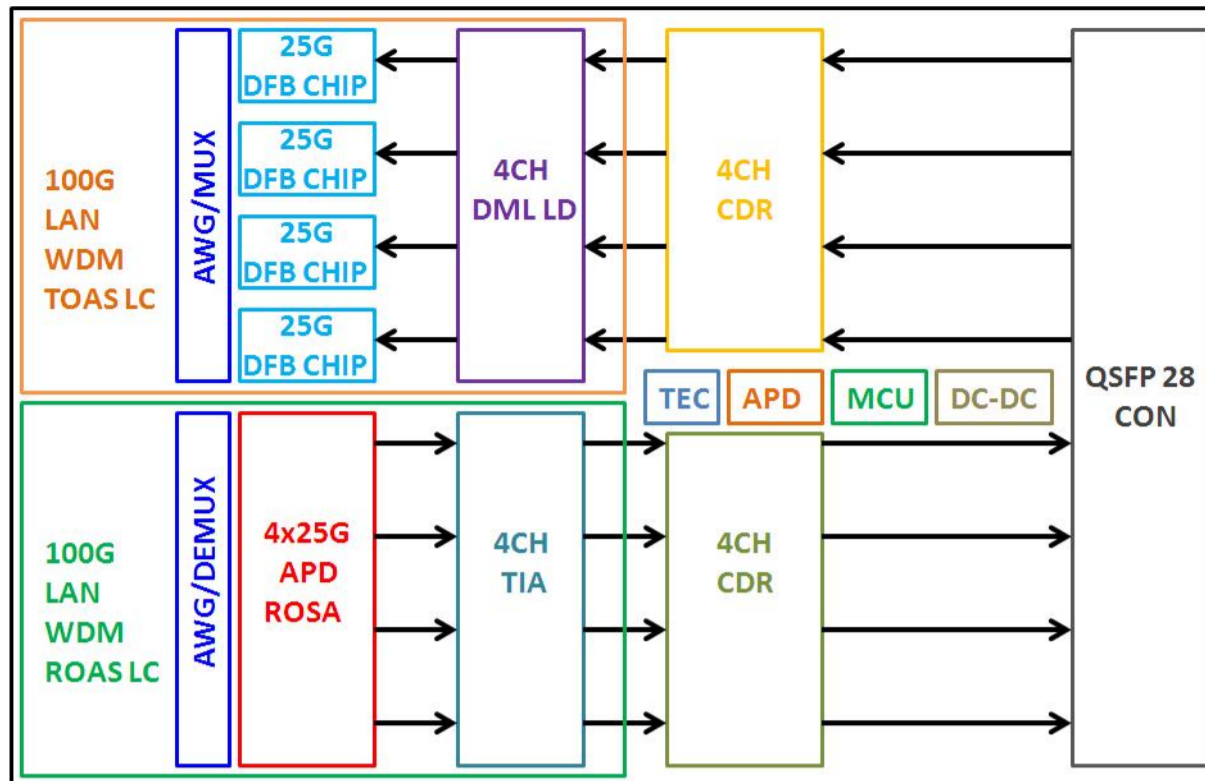

Figure1.Module Block Diagram

Absolute Maximum Ratings

Parameter	Symbol	Min	Max	Unit
Supply Voltage	Vcc	-0.3	3.6	V
Input Voltage	Vin	-0.3	Vcc+0.3	V
Storage Temperature	Tst	-20	85	°C
Case Operating Temperature	Top	0	70	°C
Humidity(non-condensing)	Rh	5	85	%
Damage Threshold, each Lane	TH		-6	dBm

Recommended Operating Conditions

Parameter	Symbol	Min	Typical	Max	Unit
Supply Voltage	Vcc	3.13	3.3	3.47	V
Operating Case temperature	Tca	0		70	°C
Data Rate Per Lane	fd		25.78125		Gbps
Humidity	Rh	5		85	%
Power Dissipation	P		3.5	3.8	W
Link Distance with G.652	D	0.002		40	km



Electrical Specifications

Parameter	Symbol	Min	Typical	Max	Unit
Power Consumption	P			4.2	W
Supply Current	I _{cc}			1.27	A
Transceiver Power-on Initialization Time				2000	ms
Transmitter(each Lane)					
Single-ended Input Voltage Tolerance		-0.3		4.0	V
AC Common Mode Input Voltage Tolerance		15			mV
Differential Input Voltage		50			mVpp
Differential Input Voltage Swing	V _{in}			900	mVpp
Differential Input Impedance	Z _{in}	90	100	110	Ohm
Receiver(each Lane)					
Single-ended Output Voltage		-0.3		4.0	V
AC Common Mode Output Voltage				7.5	mV
Differential Output Voltage Swing	V _{out}	300		850	mVpp
Differential Output Impedance	Z _{out}	90	100	110	Ohm

Note:

1. Power-on Initialization Time is the time from when the power supply voltages reach and remain above the minimum recommended operating supply voltages to the time when the module is fully functional.

Optical Characteristics

Table 3 - Optical Characteristics

QSFP28 100GBASE-ER4 Lite						
Parameter	Symbol	Min	Typical	Max	Unit	Notes
Lane Wavelength	L0	1294.53	1295.56	1296.59	nm	
	L1	1299.02	1300.05	1301.09	nm	
	L2	1303.54	1304.58	1305.63	nm	
	L3	1308.09	1309.14	1310.19	nm	
Transmitter						
SMSR	SMSR	30			dB	
Total Average Launch Power	P _T			12.5	dBm	
Average Launch Power, each Lane	P _{AVG}	-2.5		6.5	dBm	
OMA, each Lane	P _{OMA}	0.5		6.5	dBm	1
Difference in Launch Power between any Two Lanes (OMA)	P _{tx,diff}			3	dB	
Launch Power in OMA minus Transmitter and Dispersion Penalty (TDP), each Lane		-0.5			dBm	
TDP, each Lane	TDP			3.0	dB	



QSFP28 100GBASE-ER4 Lite						
Parameter	Symbol	Min	Typical	Max	Unit	Notes
Extinction Ratio	ER	4.5			dB	
RIN _{20OMA}	RIN			-130	dB/Hz	
Optical Return Loss Tolerance	TOL			20	dB	
Transmitter Reflectance	R _T			-12	dB	
Eye Mask coordinates: X1, X2, X3, Y1, Y2, Y3		{0.25, 0.4, 0.45, 0.25, 0.28, 0.4}				2
Average Launch Power OFF Transmitter, each Lane	P _{off}			-30	dBm	
Receiver						
Damage Threshold, each Lane	TH _d			-6	dBm	3
Average Receive Power, each Lane		-20.5		-7	dBm	
Receive Power (OMA), each Lane				-7	dBm	
Receiver Sensitivity (OMA), each Lane (BER = 5x10 ⁻⁵)	SEN1			-18.5	dBm	
Receiver Sensitivity (OMA), each Lane (BER = 1x10 ⁻¹²)	SEN2			-15	dBm	
StressedReceiver Sensitivity (OMA), each Lane (BER = 5x10 ⁻⁵)	SEN3			-16	dBm	4
Difference in Receive Power between any Two Lanes (OMA)	Prx,diff			3.6	dB	
LOS Assert	LOSA		-26		dBm	
LOS Deassert	LOSD		-24		dBm	
LOS Hysteresis	LOSH	0.5			dB	
Receiver Electrical 3 dB upper Cutoff Frequency, each Lane	F _c			31	GHz	
Conditions of Stress Receiver Sensitivity Test(Note 5)						
Vertical Eye Closure Penalty, each Lane			2.5		dB	5
Stressed Eye J2 Jitter, each Lane			0.33		UI	
Stressed Eye J9 Jitter, each Lane			0.48		UI	

Note:

1. Even if the TDP < 1 dB, the OMA min must exceed the minimum value specified here.
2. See Figure 4 below.
3. The receiver shall be able to tolerate, without damage, continuous exposure to a modulated optical input signal having this power level on one lane. The receiver does not have to operate correctly at this input power.
4. Measured with conformance test signal at receiver input for BER = 5x10⁻⁵ @25.78125Gbps.
5. Vertical eye closure penalty and stressed eye jitter are test conditions for measuring stressed receiver sensitivity. They are not characteristics of the receiver.



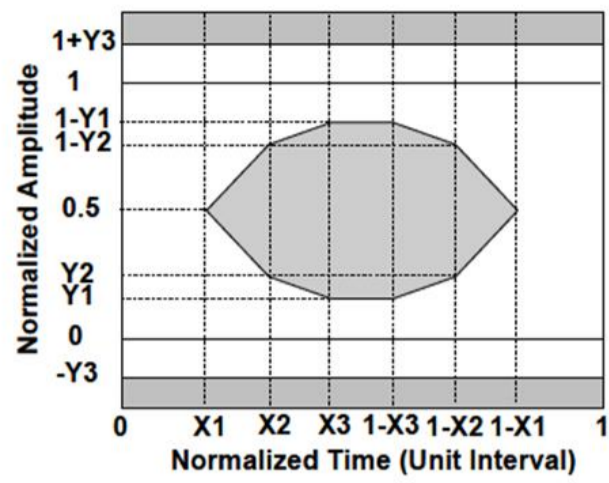

Pin Descriptions

Pin	Logic	Symbol	Name/Description	Ref.
1		GND	Module Ground	1
2	CML-I	Tx2-	Transmitter inverted data input	
3	CML-I	Tx2+	Transmitter non-inverted data input	
4		GND	Module Ground	1
5	CML-I	Tx4-	Transmitter inverted data input	
6	CML-I	Tx4+	Transmitter non-inverted data input	
7		GND	Module Ground	1
8	LVTTTL-I	MODSEIL	Module Select	2
9	LVTTTL-I	ResetL	Module Reset	2
10		VCCRx	+3.3v Receiver Power Supply	
11	LVCMOS-I	SCL	2-wire Serial interface clock	2
12	LVCMOS-I/O	SDA	2-wire Serial interface data	2
13		GND	Module Ground	1
14	CML-O	RX3+	Receiver non-inverted data output	
15	CML-O	RX3-	Receiver inverted data output	
16		GND	Module Ground	1
17	CML-O	RX1+	Receiver non-inverted data output	
18	CML-O	RX1-	Receiver inverted data output	
19		GND	Module Ground	1
20		GND	Module Ground	1
21	CML-O	RX2-	Receiver inverted data output	
22	CML-O	RX2+	Receiver non-inverted data output	
23		GND	Module Ground	1
24	CML-O	RX4-	Receiver inverted data output	
25	CML-O	RX4+	Receiver non-inverted data output	
26		GND	Module Ground	1
27	LVTTTL-O	ModPrsL	Module Present, internal pulled down to GND	



Pin	Logic	Symbol	Name/Description	Ref.
28	LVTTTL-O	IntL	Interrupt output, should be pulled up on host board	2
29		VCCTx	+3.3v Transmitter Power Supply	
30		VCC1	+3.3v Power Supply	
31	LVTTTL-I	LPMoDe	Low Power Mode	2
32		GND	Module Ground	1
33	CML-I	Tx3+	Transmitter non-inverted data input	
34	CML-I	Tx3-	Transmitter inverted data input	
35		GND	Module Ground	1
36	CML-I	Tx1+	Transmitter non-inverted data input	
37	CML-I	Tx1-	Transmitter inverted data input	
38		GND	Module Ground	1

Notes:

1. Module circuit ground is isolated from module chassis ground within the module.
2. Open collector; should be pulled up with 4.7k - 10k ohms on host board to a voltage between 3.15V and 3.6V.

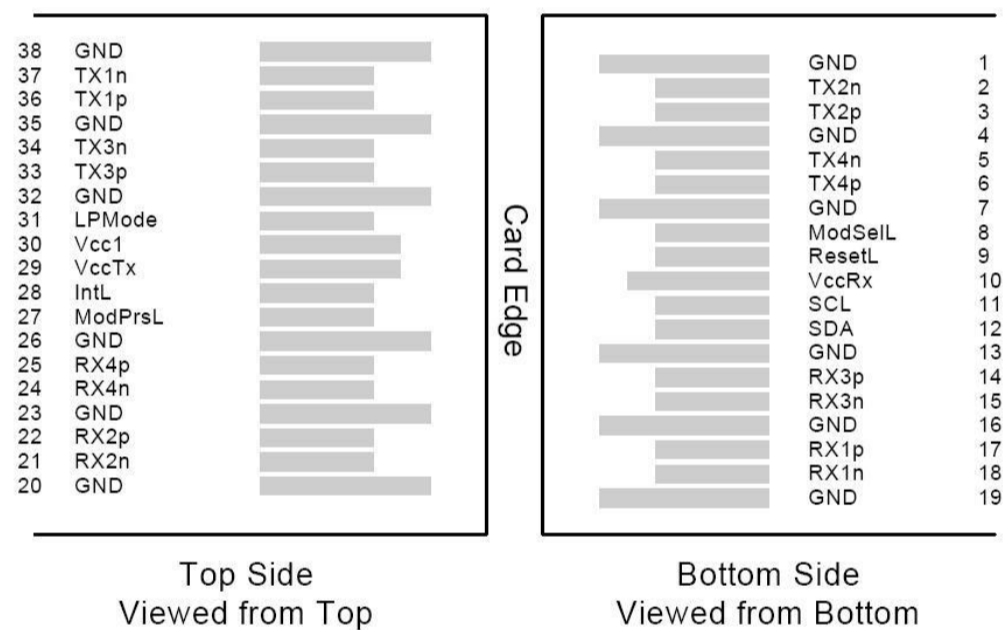

Figure 2. Electrical Pin-out Details

ModSelL Pin

The ModSelL is an input pin. When held low by the host, the module responds to 2-wire serial communication commands. The ModSelL allows the use of multiple QSFP modules on a single 2-wire interface bus. When the ModSelL is “High”, the module will not respond to any 2-wire interface communication from the host.

ModSelL has an internal pull-up in the module.

ResetL Pin

Reset. LPMoDe_Reset has an internal pull-up in the module. A low level on the ResetL pin for longer than the minimum pulse length (t_Reset_init) initiates a complete module reset, returning all user module settings to their default state. Module Reset Assert Time (t_init) starts on the rising edge after the low level on the ResetL pin is released. During the execution of a reset (t_init) the host shall disregard all status bits until the module indicates a completion of the reset interrupt. The module indicates this by posting an IntL signal with the Data_Not_Ready bit negated. Note that on power up (including hot insertion) the module will post this completion of reset interrupt without requiring a reset.



LPMode Pin

FIBERSTAMP QSFP28 SR4operate in the low power mode (less than 1.5 W power consumption)

This pin active high will decrease power consumption to less than 1W.

ModPrsL Pin

ModPrsL is pulled up to Vcc on the host board and grounded in the module. The ModPrsL is asserted “Low” when the module is inserted and deasserted “High” when the module is physically absent from the host connector.

IntL Pin

IntL is an output pin. When “Low”, it indicates a possible module operational fault or a status critical to the host system. The host identifies the source of the interrupt by using the 2-wire serial interface. The IntL pin is an open collector output and must be pulled up to Vcc on the host board.

Power Supply Filtering

The host board should use the power supply filtering shown in Figure3.

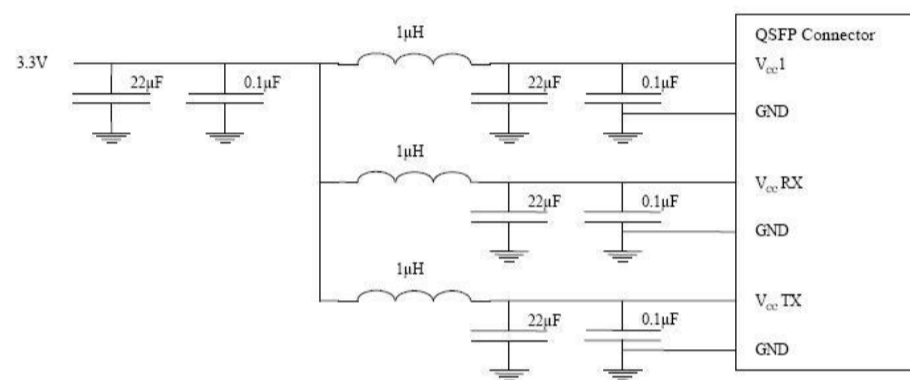

Figure3.Host Board Power Supply Filtering

DIAGNOSTIC MONITORING INTERFACE (OPTIONAL)

The following digital diagnostic characteristics are defined over the normal operating conditions unless otherwise specified.

Parameter	Symbol	Min	Max	Units	Notes
Temperature monitor absolute error	DMI_Temp	-3	+3	degC	Over operating temperature range
Supply voltage monitor absolute error	DMI_VCC	-0.1	0.1	V	Over full operating range
Channel RX power monitor absolute error	DMI_RX_Ch	-7	-22	dB	1
Channel Bias current monitor	DMI_Ibias_Ch	-10%	10%	mA	
Channel TX power monitor absolute error	DMI_TX_Ch	-2.5	6.5	dB	1

Notes:

Due to measurement accuracy of different single mode fibers, there could be an additional +/-1 dB fluctuation, or a +/- 3 dB total accuracy.

Digital diagnostics monitoring function is available on all FIBERSTAMPQSFP28 4WDM. A 2-wire serial interface provides user to contact with module.

The structure of the memory is shown inFigure 5. The memory space is arranged into a lower, single page, address space of 128 bytes and multipleupper address space pages. This structure permits timely access to addresses in the lower page, such as Interrupt Flags and Monitors. Less time critical time entries, such as serial ID information and threshold settings,are available with the Page Select function.

The interface address used is A0xh and is mainly used for time critical data like interrupt handling in order to enable a one-time-read for all data related to an interrupt situation. After an interrupt, IntL, has been asserted,the host can read out the flag field to determine the affected channel and type of flag.



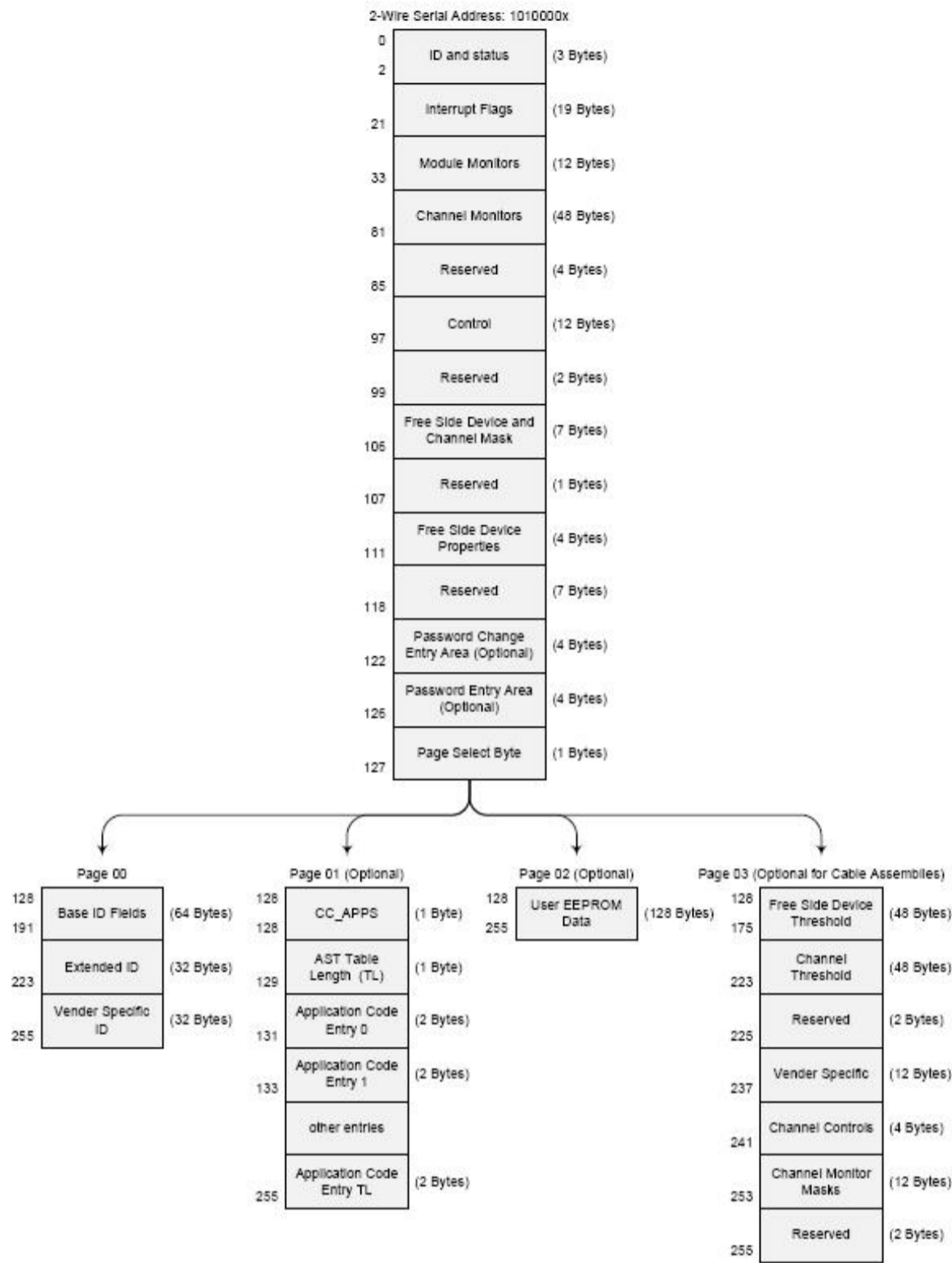

Figure3.QSFP Memory Map

Byte Address	Description	Type
0	Identifier (1 Byte)	Read Only
1-2	Status (2 Bytes)	Read Only
3-21	Interrupt Flags (31 Bytes)	Read Only
22-33	Module Monitors (12 Bytes)	Read Only
34-81	Channel Monitors (48 Bytes)	Read Only
82-85	Reserved (4 Bytes)	Read Only
86-97	Control (12 Bytes)	Read/Write
98-99	Reserved (2 Bytes)	Read/Write
100-106	Module and Channel Masks (7 Bytes)	Read/Write
107-118	Reserved (12 Bytes)	Read/Write
119-122	Reserved (4 Bytes)	Read/Write
123-126	Reserved (4 Bytes)	Read/Write
127	Page Select Byte	Read/Write

Figure3.Low Memory Map



Byte Address	Description	Type
128-175	Module Thresholds (48 Bytes)	Read Only
176-223	Reserved (48 Bytes)	Read Only
224-225	Reserved (2 Bytes)	Read Only
226-239	Reserved (14 Bytes)	Read/Write
240-241	Channel Controls (2 Bytes)	Read/Write
242-253	Reserved (12 Bytes)	Read/Write
254-255	Reserved (2 Bytes)	Read/Write

Figure5.Page 03 Memory Map

Address	Name	Description
128	Identifier (1 Byte)	Identifier Type of serial transceiver
129	Ext. Identifier (1 Byte)	Extended identifier of serial transceiver
130	Connector (1 Byte)	Code for connector type
131-138	Transceiver (8 Bytes)	Code for electronic compatibility or optical compatibility
139	Encoding (1 Byte)	Code for serial encoding algorithm
140	BR, nominal (1 Byte)	Nominal bit rate, units of 100 Mbits/s
141	Extended RateSelect Compliance (1 Byte)	Tags for Extended RateSelect compliance
142	Length SMF (1 Byte)	Link length supported for SM fiber in km
143	Length E-50 μm (1 Byte)	Link length supported for EBW 50/125 μm fiber, units of 2 m
144	Length 50 μm (1 Byte)	Link length supported for 50/125 μm fiber, units of 1 m
145	Length 62.5 μm (1 Byte)	Link length supported for 62.5/125μm fiber, units of 1 m
146	Length copper (1 Byte)	Link length supported for copper, units of 1 m
147	Device Tech (1 Byte)	Device technology
148-163	Vendor name (16 Bytes)	QSFP vendor name (ASCII)
164	Extended Transceiver (1 Byte)	Extended Transceiver Codes for InfiniBand [†]
165-167	Vendor OUI (3 Bytes)	QSFP vendor IEEE vendor company ID
168-183	Vendor PN (16 Bytes)	Part number provided by QSFP vendor (ASCII)
184-185	Vendor rev (2 Bytes)	Revision level for part number provided by vendor (ASCII)
186-187	Wavelength (2 Bytes)	Nominal laser wavelength (Wavelength = value / 20 in nm)
188-189	Wavelength Tolerance (2 Bytes)	Guaranteed range of laser wavelength (+/- value) from Nominal wavelength (Wavelength Tol. = value / 200 in nm)
190	Max Case Temp (1 Byte)	Maximum Case Temperature in Degrees C
191	CC_BASE (1 Byte)	Check code for Base ID fields (addresses 128-190)
192-195	Options (4 Bytes)	Rate Select, TX Disable, TX Fault, LOS
196-211	Vendor SN (16 Bytes)	Serial number provided by vendor (ASCII)
212-219	Date code (8 Bytes)	Vendor's manufacturing date code
220	Diagnostic Monitoring Type (1 Byte)	Indicates which type of diagnostic monitoring is implemented
221	Enhanced Options (1 Byte)	Indicates which optional enhanced features are implemented
222	Reserved (1 Byte)	Reserved
223	CC_EXT	Check code for the Extended ID Fields (addresses 192-222)
224-255	Vendor Specific (32 Bytes)	Vendor Specific EEPROM

Figure6.Page 00 Memory Map

Page02 is User EEPROM and its format decided by user.

The detail description of low memory and page00.page03 upper memory please see SFF-8436 document.

Timing for Soft Control and Status Functions

Parameter	Symbol	Max	Unit	Conditions
Initialization Time	t_init	2000	ms	Time from power on ¹ , hot plug or rising edge of Reset until the module is fully functional ²
Reset Init Assert Time	t_reset_init	2	μs	A Reset is generated by a low level longer than the minimum reset pulse time present on the ResetL pin.
Serial Bus Hardware Ready Time	t_serial	2000	ms	Time from power on ¹ until module responds to data transmission over the 2-wire serial bus
Monitor Data Ready Time	t_data	2000	ms	Time from power on ¹ to data not ready, bit 0 of Byte 2, deasserted and IntL asserted
Reset Assert Time	t_reset	2000	ms	Time from rising edge on the ResetL pin until the module is fully functional ²



Parameter	Symbol	Max	Unit	Conditions
LPMODE Assert Time	ton_LPMODE	100	μs	Time from assertion of LPMODE (Vin:LPMODE = Vih) until module power consumption enters lower Power Level
IntL Assert Time	ton_IntL	200	ms	Time from occurrence of condition triggering IntL until Vout:IntL = Vol
IntL Deassert Time	toff_IntL	500	μs	Time from clear on read ³ operation of associated flag until Vout:IntL = Voh. This includes deassert times for Rx LOS, Tx Fault and other flag bits.
Rx LOS Assert Time	ton_los	100	ms	Time from Rx LOS state to Rx LOS bit set and IntL asserted
Tx Fault Assert Time	ton_Txfault	200	ms	Time from Tx Fault state to Tx Fault bit set and IntL asserted
Flag Assert Time	ton_flag	200	ms	Time from occurrence of condition triggering flag to associated flag bit set and IntL asserted
Mask Assert Time	ton_mask	100	ms	Time from mask bit set ⁴ until associated IntL assertion is inhibited
Mask Deassert Time	toff_mask	100	ms	Time from mask bit cleared ⁴ until associated IntL operation resumes
ModSelL Assert Time	ton_ModSelL	100	μs	Time from assertion of ModSelL until module responds to data transmission over the 2-wire serial bus
ModSelL Deassert Time	toff_ModSelL	100	μs	Time from deassertion of ModSelL until the module does not respond to data transmission over the 2-wire serial bus
Power_over-ride or Power-set Assert Time	ton_Pdown	100	ms	Time from P_Down bit set ⁴ until module power consumption enters lower Power Level
Power_over-ride or Power-set Deassert Time	toff_Pdown	300	ms	Time from P_Down bit cleared ⁴ until the module is fully functional ³

Note:

1. Power on is defined as the instant when supply voltages reach and remain at or above the minimum specified value.
2. Fully functional is defined as IntL asserted due to data not ready bit, bit 0 byte 2 deasserted.
3. Measured from falling clock edge after stop bit of read transaction.
4. Measured from falling clock edge after stop bit of write transaction.

Mechanical Dimensions

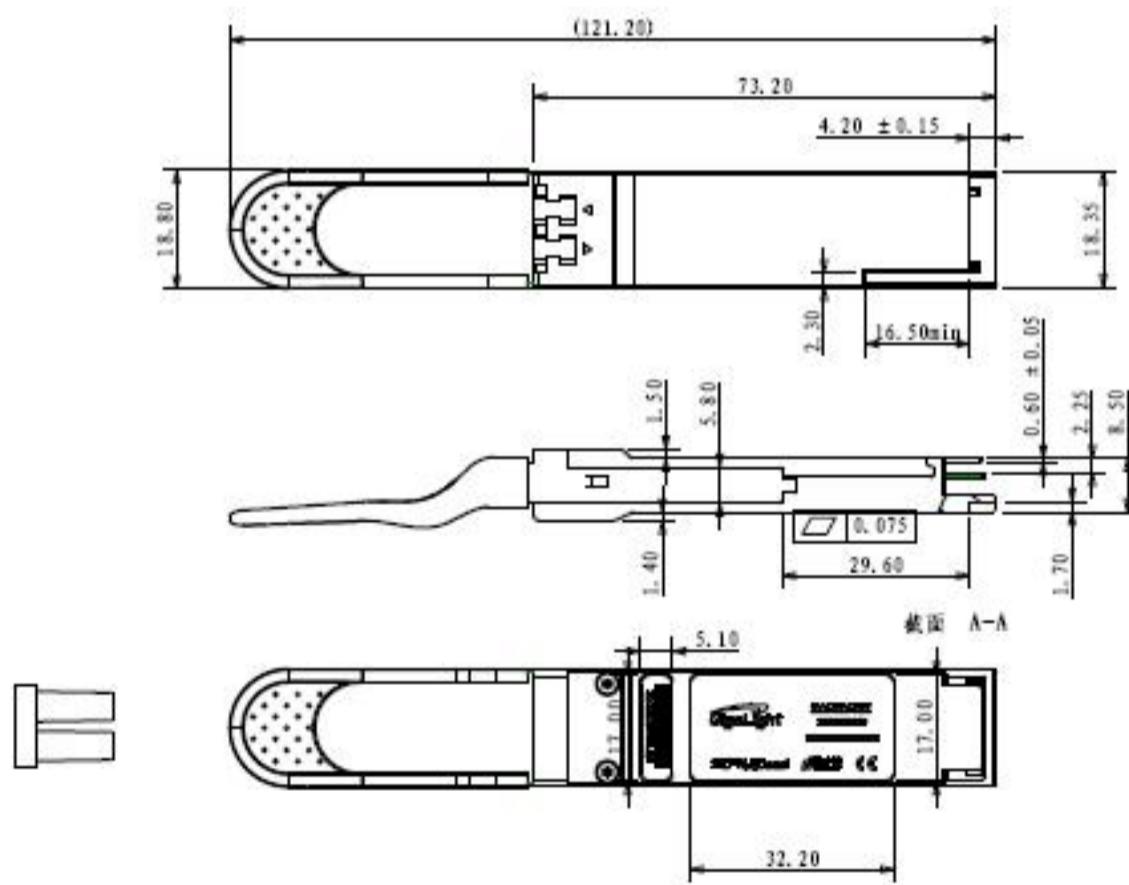

Figure7.Mechanical Specifications

Ordering information

Part Number	Product Description
FST-100G-ER4L	100GE QSFP28 ER4 Lite 30km w/o FEC/40km with FEC, Single rate 100GE

Package information

- 1pcs 10dB attenuator (the attenuator could be removed from transceiver for normal use)
- 1pcs FST-100G-ER4L transceiver





Attenuator



FST-100G-ER4L transceiver with attenuator (for reference only)

References

1. SFF-8436 QSFP+
2. Ethernet 100GBASE-ER4
3. QSFP28 4WDM 40KM

ESD

This transceiver is specified as ESD threshold 1kV for SFI pins and 2kV for all other electrical input pins, tested per MIL-STD-883, Method 3015.4 /JESD22-A114-A (HBM). However, normal ESD precautions are still required during the handling of this module. This transceiver is shipped in ESD protective packaging. It should be removed from the packaging and handled only in an ESD protected environment.

Laser Safety

This is a Class 1 Laser Product according to IEC 60825-1:2007. This product complies with 21 CFR 1040.10 and 1040.11 except for deviations pursuant to Laser Notice No. 50, dated (June 24, 2007).

Important Notice

Performance figures, data and any illustrative material provided in this data sheet are typical and must be specifically confirmed in writing by FIBERSTAMP before they become applicable to any particular order or contract. In accordance with the FIBERSTAMP policy of continuous improvement specifications may change without notice.

The publication of information in this data sheet does not imply freedom from patent or other protective rights of FIBERSTAMP or others. Further details are available from any FIBERSTAMP sales representative.

