

100G-FR1-2km QSFP28 Optical Transceiver

FBG-100GP4K02C

Features

- Compliant to 100G Lambda MSA 100G FR1
- Full-duplex transceiver module
- 4x25.78125Gbps NRZ electrical interface(CAUI-4)
- 106.25Gbps PAM4 based on a cooled EML TOSA transmitter
- 106.25Gbps PAM4 PIN Receiver
- 4W maximum power dissipation
- Hot-pluggable QSFP28 form factor
- Maximum link length of 2km on G.652 SMF with KP-FEC
- Duplex LC receptacles
- Built-in digital diagnostic functions
- Operating case temperature range: 0 to 70°C
- Single 3.3V power supply
- RoHS compliant (lead free)



Applications

- Lambda 100G-FR and 100G-LR Technical Spec D2p0

Description

The FIBERSTAMP 100G FR1-2km QSFP28 optical transceiver, 100G QSFP28 FR1 (FBG-100GP4K02C) is designed for using in 100-Gigabit Ethernet links up to 2km over Single-Mode Fiber (SMF). It is compliant with the QSFP28 MSA ,100G Lambda 100G FR1 and CAUI-4(no FEC)1. Digital diagnostics functions are available via the I2C interface, as specified by the QSFP28 MSA.

The module incorporates 1 channel optical signal, on 1311nm center wavelength, operating at 100Gbps data rate. This module can convert 4 channels of 25Gbps (NRZ) electrical input data to 1 channel of 100Gbps (PAM4) optical signal, and also can convert 1 channel of 100Gbps (PAM4) optical signal to 4 channels of 25Gbps (NRZ) electrical output data. The electrical interface uses a 38-contact edge type connector. The optical interface uses a Duplex LC connector. The high performance cooled EML transmitter and high sensitivity PIN receiver provide superior performance for 100Gigabit Ethernet applications up to 2km links.

Note:

1. KR-FEC is optional, please contact us if necessary.

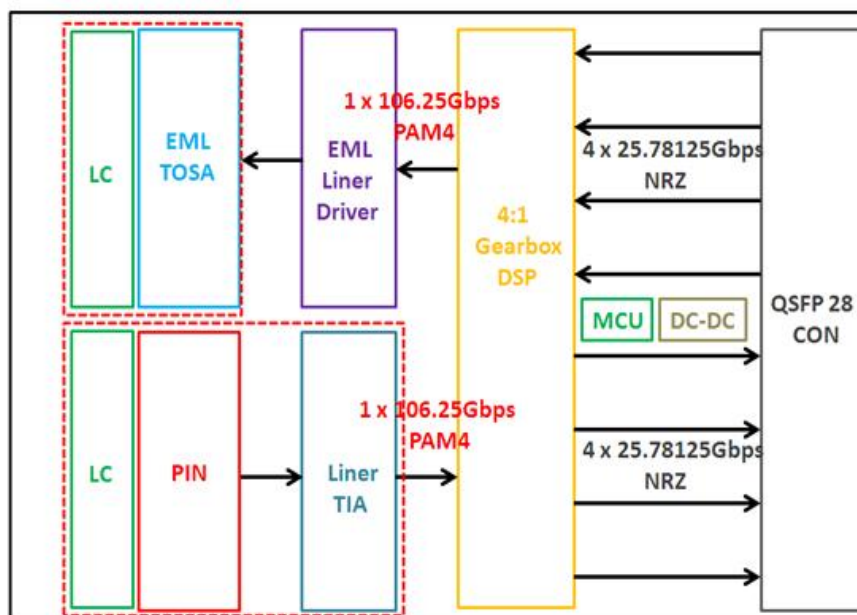

Figure 1. Module Block Diagram



Absolute Maximum Ratings

Parameter	Symbol	Min	Max	Unit
Supply Voltage	Vcc	-0.3	3.6	V
Input Voltage	Vin	-0.3	Vcc+0.3	V
Storage Temperature	Ts	-20	85	°C
Case Operating Temperature	Tc	0	70	°C
Humidity (non-condensing)	Rh	5	85	%

Recommended Operating Conditions

Parameter	Symbol	Min	Typical	Max	Unit
Supply Voltage	Vcc	3.13	3.3	3.47	V
Operating Case temperature	Tc	0	-	70	°C
Data Rate Per Lane	fd	-	106.25	-	Gb/s
Humidity	Rh	5	-	85	%
Power Dissipation	Pm	-	-	4	W
Link Distance with G.652	D	-	-	2	km

Electrical Specifications

Parameter	Symbol	Min	Typical	Max	Unit
Differential Input Impedance	Zin	90	100	110	ohm
Differential Output Impedance	Zout	90	100	110	ohm
Differential Input Voltage Amplitude1	ΔV_{in}	-	-	1600	mVp-p
Differential Output Voltage Amplitude2	ΔV_{out}	-	-	900	mVp-p

Note:

1. Differential input voltage amplitude is measured between TxnP and TxnN.
2. Differential output voltage amplitude is measured between RxnP and RxnN.

Optical Characteristics

Parameter	Symbol	Min	Typical	Max	Unit	Notes
Transmitter						
Centre Wavelength	λ_c	1304.5	-	1317.5	nm	-
Side-mode suppression ratio	SMSR	30	-	-	dB	-
Average launch power	Pout	-2.4	-	4	dBm	-
Optical Modulation Amplitude(OA outer)	OMA	-0.2	-	4.2	dBm	-
Transmitter and dispersion eye closure(TDECQ)	TDECQ	-	-	3.4	dB	-
Extinction Ratio	ER	3.5	-	-	dB	-
Average launch power of OFF transmitter		-	-	-30	dB	-
Receiver						
Centre Wavelength	λ_c	1304.5	-	1317.5	nm	-
Receiver Sensitivity in OMA outer	RXsen	-	-	-4.5	dBm	1

Parameter	Symbol	Min	Typical	Max	Unit	Notes
Average receive power	Pin	-6.4	-	4.5	dBm	-
Receiver Reflectance		-	-	-26	dB	-
LOS Assert		-	-13	-	dBm	-
LOS De-Assert - OMA		-	-11	-	dBm	-
LOS Hysteresis		0.5	-	-	dB	-

Note:

1. Measured with conformance test signal at TP3 for BER = 2.4E-4 Pre-FECs

Pin Description

Pin	Logic	Symbol	Name/Description
1		GND	Module Ground1
2	CML-I	Tx2-	Transmitter inverted data input
3	CML-I	Tx2+	Transmitter non-inverted data input
4		GND	Module Ground1
5	CML-I	Tx4-	Transmitter inverted data input
6	CML-I	Tx4+	Transmitter non-inverted data input
7		GND	Module Ground1
8	LVTTL-I	MODSEL	Module Select2
9	LVTTL-I	ResetL	Module Reset2
10		VCCR _x	+3.3V Receiver Power Supply
11	LVCMOS-I	SCL	2-wire Serial interface clock2
12	LVCMOS-I/O	SDA	2-wire Serial interface data2
13		GND	Module Ground1
14	CML-O	RX3+	Receiver non-inverted data output
15	CML-O	RX3-	Receiver inverted data output
16		GND	Module Ground1
17	CML-O	RX1+	Receiver non-inverted data output
18	CML-O	RX1-	Receiver inverted data output
19		GND	Module Ground1
20		GND	Module Ground1
21	CML-O	RX2-	Receiver inverted data output
22	CML-O	RX2+	Receiver non-inverted data output
23		GND	Module Ground1
24	CML-O	RX4-	Receiver inverted data output
25	CML-O	RX4+	Receiver non-inverted data output
26		GND	Module Ground1
27	LVTTL-O	ModPrsL	Module Present, internal pulled down to GND



Pin	Logic	Symbol	Name/Description
28	LVTTTL-O	IntL	Interrupt output, should be pulled up on host board2
29		VCCTx	+3.3V Transmitter Power Supply
30		VCC1	+3.3V Power Supply
31	LVTTTL-I	LPMode	Low Power Mode2
32		GND	Module Ground1
33	CML-I	Tx3+	Transmitter non-inverted data input
34	CML-I	Tx3-	Transmitter inverted data input
35		GND	Module Ground1
36	CML-I	Tx1+	Transmitter non-inverted data input
37	CML-I	Tx1-	Transmitter inverted data input
38		GND	Module Ground1

Note:

Module circuit ground is isolated from module chassis ground within the module.

Open collector should be pulled up with 4.7K to 10K ohms on host board to a voltage between 3.15V and 3.6V.

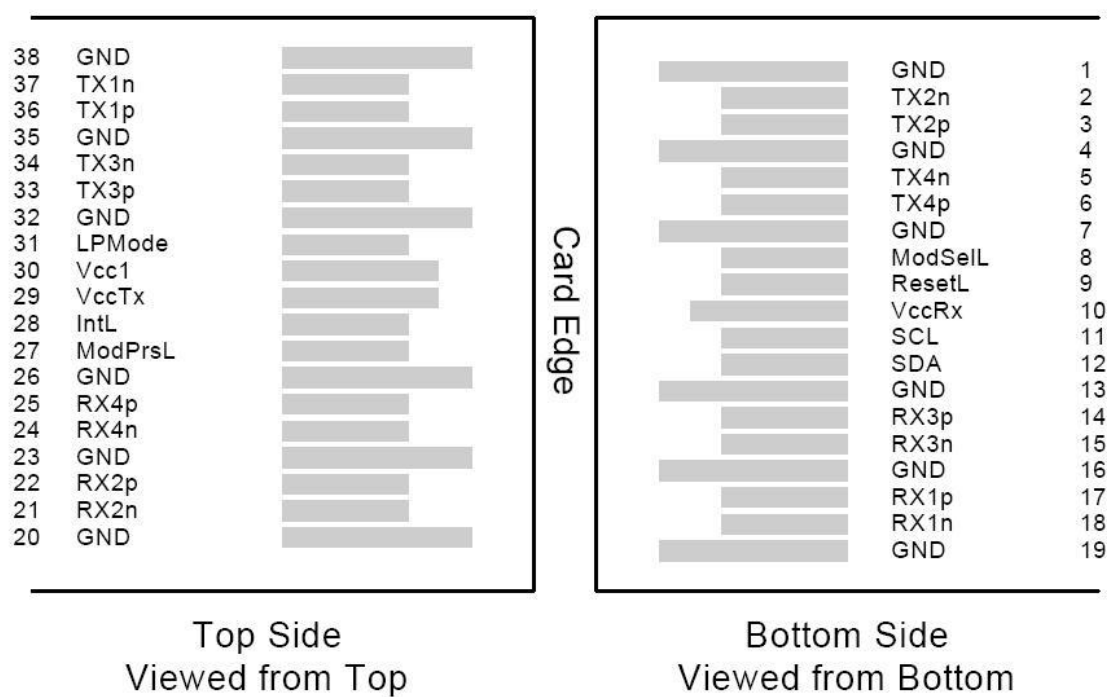

Figure 2. Electrical Pin-out Details

ModSelL Pin

The ModSelL is an input pin. When held low by the host, the module responds to 2-wire serial communication commands. The ModSelL allows the use of multiple QSFP modules on a single 2-wire interface bus. When the ModSelL is "High", the module will not respond to any 2-wire interface communication from the host. ModSelL has an internal pull-up in the module.

ResetL Pin

Reset. LPMode_Reset has an internal pull-up in the module. A low level on the ResetL pin for longer than the minimum pulse length (t_{Reset_init}) initiates a complete module reset, returning all user module settings to their default state. Module Reset Assert Time (t_{init}) starts on the rising edge after the low level on the ResetL pin is released. During the execution of a reset (t_{init}) the host shall disregard all status bits until the module indicates a completion of the reset interrupt. The module indicates this by posting an IntL signal with the Data_Not_Ready bit negated. Note that on power up (including hot insertion) the module will post this completion of reset interrupt without requiring a reset.

LPMode Pin

FIBERSTAMP QSFP28 modules operate in the low power mode (less than 1.5 W power consumption). This pin active high will decrease power consumption to less than 1W.

ModPrsL Pin

ModPrsL is pulled up to Vcc on the host board and grounded in the module. The ModPrsL is asserted "Low" when the module is inserted and deasserted "High" when the module is physically absent from the host connector.

IntL Pin

IntL is an output pin. When "Low" , it indicates a possible module operational fault or a status critical to the host system. The host identifies the source of the interrupt by using the 2-wire serial interface. The IntL pin is an open collector output and must be pulled up to Vcc on the host board.

Power Supply Filtering

The host board should use the power supply filtering shown in Figure 3.

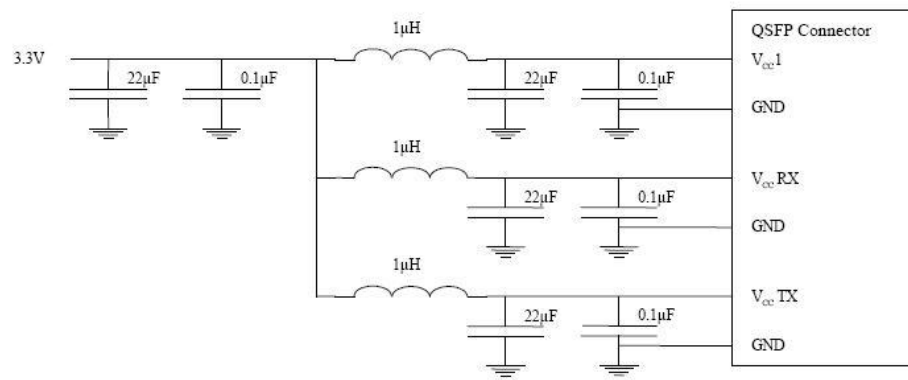

Figure 3. Host Board Power Supply Filtering

DIAGNOSTIC MONITORING INTERFACE (OPTIONAL)

The following digital diagnostic characteristics are defined over the normal operating conditions unless otherwise specified.

Parameter	Symbol	Min	Max	Units	Notes
Temperature monitor absolute error	DMI_Temp	-3	+3	degC	Over operating temperature range
Supply voltage monitor absolute error	DMI_VCC	-0.1	0.1	V	Over full operating range
Channel RX power monitor absolute error	DMI_RX_Ch	-2	2	dB	1
Channel Bias current monitor	DMI_Ibias_Ch	-10%	10%	mA	
Channel TX power monitor absolute error	DMI_TX_Ch	-2	2	dB	1

Notes:

1. Due to measurement accuracy of different single mode fibers, there could be an additional +/-1 dB fluctuation, or a +/- 3 dB total accuracy.

Digital diagnostics monitoring function is available on all FIBERSTAMP QSFP28 transceivers. A 2-wire serial interface provides user to contact with module.

The structure of the memory is shown in Figure 4. The memory space is arranged into a lower, single page, address space of 128 bytes and multiple upper address space pages. This structure permits timely access to addresses in the lower page, such as Interrupt Flags and Monitors. Less time critical time entries, such as serial ID information and threshold settings, are available with the Page Select function.

The interface address used is A0xh and is mainly used for time critical data like interrupt handling in order to enable a one-time-read for all data related to an interrupt situation. After an interrupt, IntL, has been asserted, the host can read out the flag field to determine the affected channel and type of flag.



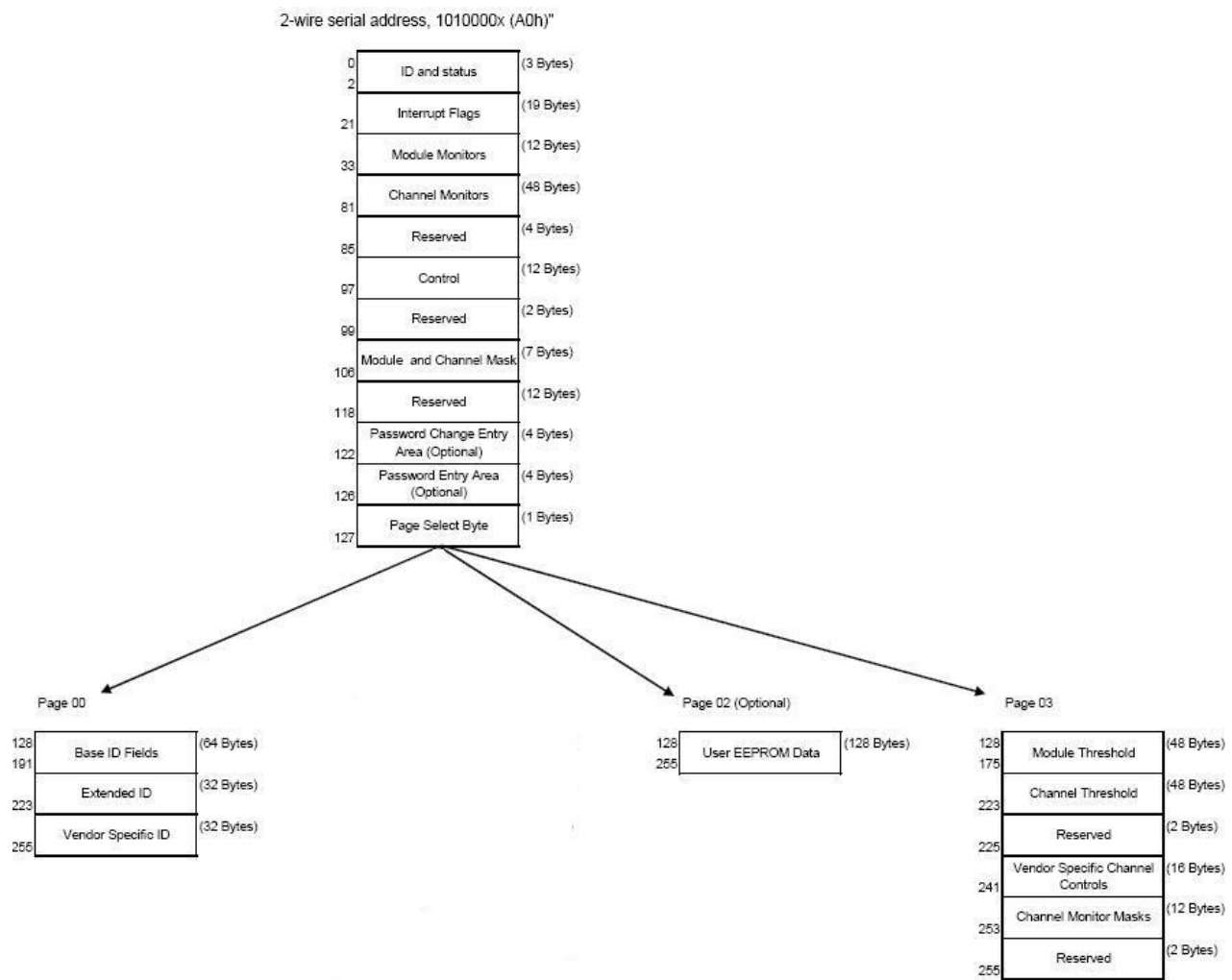

Figure 4. QSFP28 Memory Map

Byte Address	Description	Type
0	Identifier (1 Byte)	Read Only
1-2	Status (2 Bytes)	Read Only
3-21	Interrupt Flags (31 Bytes)	Read Only
22-33	Module Monitors (12 Bytes)	Read Only
34-81	Channel Monitors (48 Bytes)	Read Only
82-85	Reserved (4 Bytes)	Read Only
86-97	Control (12 Bytes)	Read/Write
98-99	Reserved (2 Bytes)	Read/Write
100-106	Module and Channel Masks (7 Bytes)	Read/Write
107-118	Reserved (12 Bytes)	Read/Write
119-122	Reserved (4 Bytes)	Read/Write
123-126	Reserved (4 Bytes)	Read/Write
127	Page Select Byte	Read/Write

Figure 5. Low Memory Map

Byte Address	Description	Type
128-175	Module Thresholds (48 Bytes)	Read Only
176-223	Reserved (48 Bytes)	Read Only
224-225	Reserved (2 Bytes)	Read Only
226-239	Reserved (14 Bytes)	Read/Write
240-241	Channel Controls (2 Bytes)	Read/Write
242-253	Reserved (12 Bytes)	Read/Write
254-255	Reserved (2 Bytes)	Read/Write

Figure 6. Page 03 Memory Map



Address	Name	Description
128	Identifier (1 Byte)	Identifier Type of serial transceiver
129	Ext. Identifier (1 Byte)	Extended identifier of serial transceiver
130	Connector (1 Byte)	Code for connector type
131-138	Transceiver (8 Bytes)	Code for electronic compatibility or optical compatibility
139	Encoding (1 Byte)	Code for serial encoding algorithm
140	BR, nominal (1 Byte)	Nominal bit rate, units of 100 Mbits/s
141	Extended RateSelect Compliance (1 Byte)	Tags for Extended RateSelect compliance
142	Length SMF (1 Byte)	Link length supported for SM fiber in km
143	Length E-50 μ m (1 Byte)	Link length supported for EBW 50/125 μ m fiber, units of 2 m
144	Length 50 μ m (1 Byte)	Link length supported for 50/125 μ m fiber, units of 1 m
145	Length 62.5 μ m (1 Byte)	Link length supported for 62.5/125 μ m fiber, units of 1 m
146	Length copper (1 Byte)	Link length supported for copper, units of 1 m
147	Device Tech (1 Byte)	Device technology
148-163	Vendor name (16 Bytes)	QSFP vendor name (ASCII)
164	Extended Transceiver (1 Byte)	Extended Transceiver Codes for InfiniBand [†]
165-167	Vendor OUI (3 Bytes)	QSFP vendor IEEE vendor company ID
168-183	Vendor PN (16 Bytes)	Part number provided by QSFP vendor (ASCII)
184-185	Vendor rev (2 Bytes)	Revision level for part number provided by vendor (ASCII)
186-187	Wavelength (2 Bytes)	Nominal laser wavelength (Wavelength = value / 20 in nm)
188-189	Wavelength Tolerance (2 Bytes)	Guaranteed range of laser wavelength (+/- value) from Nominal wavelength (Wavelength Tol. = value / 200 in nm)
190	Max Case Temp (1 Byte)	Maximum Case Temperature in Degrees C
191	CC_BASE (1 Byte)	Check code for Base ID fields (addresses 128-190)
192-195	Options (4 Bytes)	Rate Select, TX Disable, TX Fault, LOS
196-211	Vendor SN (16 Bytes)	Serial number provided by vendor (ASCII)
212-219	Date code (8 Bytes)	Vendor's manufacturing date code
220	Diagnostic Monitoring Type (1 Byte)	Indicates which type of diagnostic monitoring is implemented
221	Enhanced Options (1 Byte)	Indicates which optional enhanced features are implemented
222	Reserved (1 Byte)	Reserved
223	CC_EXT	Check code for the Extended ID Fields (addresses 192-222)
224-255	Vendor Specific (32 Bytes)	Vendor Specific EEPROM

Figure 7. Page 00 Memory Map

Page02 is User EEPROM and its format decided by user.

The detail description of low memory and Page 00, Page 03 upper memory please see SFF-8436 document.

Mechanical Dimensions

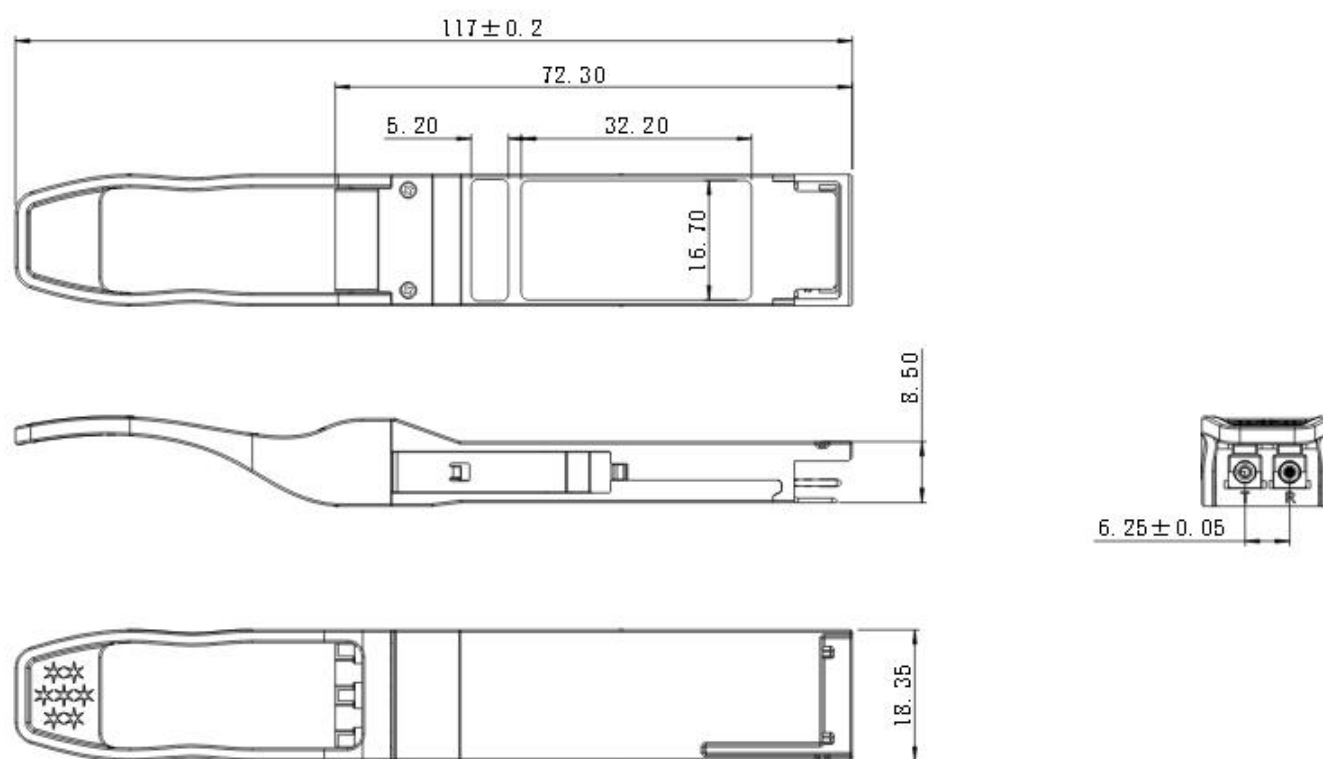

Figure 8. Mechanical Specifications

Regulatory Compliance

FIBERSTAMP FBG-100GP4K02C transceivers are Class 1 Laser Products. They meet the requirements of the following standards.

Feature	Standard
Laser Safety	IEC 60825-1:2014 (3rd Edition)
Electrical Safety	EN 62368-1: 2014
Environmental protection	Directive 2011/65/EU with amendment(EU)2015/863
CE EMC	EN55032: 2015
FCC	FCC Part 15, Subpart B

References

QSFP28 MSA

SFF-8436 QSFP+

100G Lambda MSA 100G FR1

Ordering Information

Part Number	Product Description
FBG-100GP4K02C	QSFP28 FR1, 106.25Gb/s, 2km, EML+PIN, SMF, Dual LC

CAUTION:

Use of controls or adjustment or performance of procedures other than those specified herein may result in hazardous radiation exposure.

Important Notice

Performance figures, data and any illustrative material provided in this data sheet are typical and must be specifically confirmed in writing by FIBERSTAMP before they become applicable to any particular order or contract. In accordance with the FIBERSTAMP policy of continuous improvement specifications may change without notice.

The publication of information in this data sheet does not imply freedom from patent or other protective rights of FIBERSTAMP or others. Further details are available from any FIBERSTAMP sales representative.

