

Features

- ✓ Operating optical data rate up to 128Gbps
- ✓ Transmission distance up to 1200km
- ✓ CD tolerance max. 25000ps/nm or 40000ps/nm
- ✓ DGD tolerance 50ps
- ✓ Low latency SD-FEC
- ✓ Full C-band 50GHz ITU-T Grid
- ✓ Built-in client and line OTN processing
- ✓ Hot-pluggable electrical interface
- ✓ Typical power dissipation 28W
- ✓ Operating case temperature 0°C to 70°C
- ✓ Single 3.3V power supply
- ✓ Dual LC
- ✓ CFP MSA compliant
- ✓ IEEE 802.3ba MAC compliant
- ✓ OTL4.10 and CAUI-10 compatible
- ✓ PRBS generation and detection for line and host interfaces
- ✓ RoHS compliant (lead-free)
- ✓ Single ITLA



Applications

- ✓ 100GE LH
- ✓ OTN OTU4

Description

FIBERSTAMP's 100G CFP-DCO LH is a hot-pluggable CFP form factor optical transponder designed for high-speed optical networking applications, and supports 100G Ethernet and OTN OTU4, with CAUI and OTL4.10 electrical interface and MDIO module management interface. The module converts 10-lane OTU4/100GE electrical data streams to DP-D/QPSK optical output signal in egress, and also converts DP-D/QPSK optical input signals to 10-lane electrical data streams in ingress. This 10-lane electrical signal is fully compliant with 802.3ba CAUI specification and OIF-CEI-03.1 specification, and allows M6 host PCB trace up to 25cm. The block diagram is illustrated below. DSP is used for electric data signals generation and recovery. ITLA is a full C-band wavelength tunable assemble which is used for optical signal carrier in egress and for coherent receive in ingress. MZM is used for E-O convert in egress and ICR is used for O-E convert in ingress. The optical signals format is DP-D/QPSK. EDFA is optional for optical signal amplify that we can get suitable output optical power.

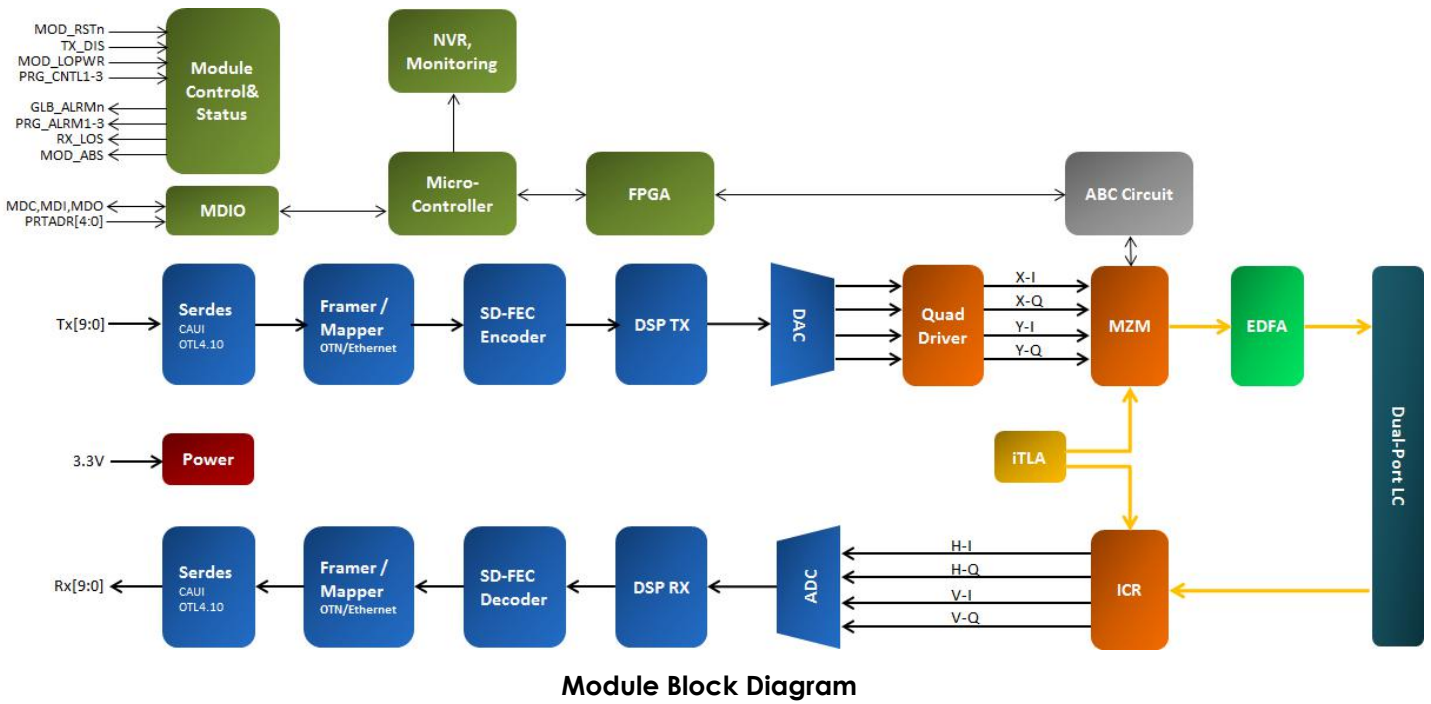

Absolute Maximum Ratings

Parameter	Symbol	Unit	Min	Max
Storage Temperature Range	Ts	°C	-40	+85
Relative Humidity	RH	%	5	85
Power Supply Voltage	Vcc	V	-0.5	+ 3.6
Operating Case Temperature Range	Tc	°C	-5	75
Receiver Optical Power	Pdag	dBm		+3

Recommended Operating Conditions

Parameter	Symbol	Unit	Min	Typical	Max
Operating Case Temperature Range	Tc	°C	0		70
Power Supply Voltage	Vcc	V	3.2	3.3	3.4
Data rate		Gb/s		103.125	128

Products Characteristics

(Tested under recommended operating conditions)

Parameter	Symbol	Unit	Min	Typical	Max	Notes
Voltage Supply Electrical Characteristics						
Supply Current		A	-	-	12	
Power Supply Noise	Vrip				2%	DC-1MHz
					3%	1-10MHz
Dissipation Class3/4	Pw	W		28	31	LH
Low Power Dissipation	Plow	W			2	
Inrush Current _{n2}	I-inrush mA/usec				100	
Turn-off Current ^{Class2}	I-turnoff mA/usec		-100			
Different Signal Electrical Characteristics						
Single Ended Data Input Swing		mV	55		525	
Single Ended Data Output Swing		mV	180		385	
Differential Signal Resistance	Output	Ω	80		120	
Differential Signal Resistance	Input	Ω	80		120	
3.3V LVCMOS Electrical Characteristics						
Input High Voltage	3.3VIH	V	2.0		Vcc+0.3	
Input Low Voltage	3.3VIL	V	-0.3		0.8	
Input Leakage Current	3.3IIN	μA	-10		+ 10	
Output High Voltage (I _{OH} =100μA)	3.3VOH	V	Vcc-0.2		-	
Output Low Voltage (I _{OL} =100μA)	3.3VOL	V			0.2	

Minimum Pulse Width of Control Pin Signal	T_CNTL	us	100			
1.2V LVC MOS Electrical Characteristics						
Input High Voltage	1.2VIH	V	0.84		1.5	
Input Low Voltage	1.2VIL	V	-0.3		0.36	
Input Leakage Current	1.2IIN	uA	-100		+ 100	
Output High Voltage	1.2VOH	V	1.0		1.5	
Output Low Voltage	1.2VOL	V	-0.3		0.2	
Output High Current	1.2IOH	mA			-4	
Output Low Current	1.2IOL	mA	+4			
Input Capacitance	Ci	pF			10	
Optical Transmitter Characteristics						
Signaling Rate for Each Lane (100GE)		Gbps	-	25.78125+/-100ppm		100GE
Signaling Rate for Each Lane (OTU4)				27.95249+/-20ppm		OTU4
Wavelength Range	DWDM	nm	1529.16	-	1567.13	
Channel Spacing	F_SPACING	GHz	50			
Laser Tuning Range	F_TUNE	Full C-band 96				
Wavelength Accuracy	λ_{EOL}	GHz	-2	-	2	
Output Power	P_OUT	dBm	-12	-8	-6	w/o EDFA fixed adjustable
Output Power Accuracy	P-a	dB	-1		1	BOL
			-2		2	EOL
Output Power Stability	Short time	dB	-0.3		0.3	

Shutdown Optical Power	POFF	dBm			-40	
Spectral Width @-20dB		GHz		50	53	
Transmitter Warm-Start Ready Time		ms		100		
Transmitter Cold-start Ready Time		s		120		
Transmitter OSNR		dB/0.1nm	35			
Transmitter Polarization Imbalance		dB	-1		1	
Optical Receiver Characteristics						
Receive Rate for Each Lane (100GE)		Gbps		25.78125+/-100ppm		100GE
Receive Rate for Each Lane (OTU4)				27.95249+/-20ppm		OTU4
Wavelength Range	DWDM	nm	1529.16	-	1567.13	
Receiver Operating Range	Pw	dBm	-18	-	0	
Receiver B2B Optical Power Sensitivity ²	O_sense	dBm	-21			
LOS assert	LOS_a	dBm			-21	
LOS De-assert	LOS_d	dBm	-18			
LOS hysteresis	LOS_h	dB		0.5		
OSNR (@BER=2E-2)	OSNR _{MIN}	dB/0.1nm		13		SD-FEC
Chromatic Dispersion Compensation ³	CD	ps/nm			25000/ 45000	LH
Filter Tolerance	OTF	GHz	30	45		
PMD Capability (DGD)	DGD	ps			50	

PDL Tolerance	PDL	dB			3	
Polarization SOP Tracking	SOP	kHz			20	
Receiver Warm-Start Turn-Up Time		s			30	
Receiver Cold-Start Turn-Up Time		s		60		

Notes:

1. The supply current includes CFP module's supply current in pending status.
2. The module will be switched into Hold-state when input power lower than -21dBm.
3. Please specify the CD requirement by ordering.

Hardware Control Pins

The CFP Module support real-time control functions via hardware pins, listed in the following table.

Pin#	Symbol	Description	I/O	Logic	H	L	Pull-up/down
30	PRG_CNTL1	Programmable Control 1 MSADefault: TRXIC_RST n, TX&RX ICs reset, "0": reset; "1"	I	3.3V LVCMOS	Per CFP MSA Management Interface Specification		Pull-Up ¹
31	PRG_CNTL2	Programmable Control 2 MSA Default: Hardware Interlock LSB	I	3.3V LVCMOS			Pull-Up ¹
32	PRG_CNTL3	Programmable Control 3 MSA Default: Hardware Interlock MSB	I	3.3V LVCMOS			Pull-Up ¹
36	TX_DIS	Transmitter Disable	I	3.3V LVCMOS	Disable	Enable	Pull-Up ¹
37	MOD_LOPW R	Module Low Power Mode	I	3.3V LVCMOS	Low Power	Enable	Pull-Up ¹
39	MOD_RST _n	Module Reset(Invert)	I	3.3V LVCMOS	Enable	Reset	Pull-Down ²

Notes:

1. Pull-Up resistor (4.7KOhm to 10Kohm) is located within the CFP module.
2. Pull-Down resistor (4.7KOhm to 10Kohm) is located within the CFP module.

Hardware Alarm Pins

The CFP Module supports alarm hardware pins listed in the following table.

Pin#	Symbol	Description	I/O	Logic	H	L	Pull-up/down
33	PRG ALRM 1	Programmable Alarm 1 MSA Default: HIPWR_ON	O	3.3V LVCMOS	Active High per MDIO document		
34	PRG ALRM 2	Programmable Alarm 2 MSA Default: MOD_READY , Ready State has been reached	O	3.3V LVCMOS			
35	PRG ALRM3	Programmable Alarm 3 MSA Default: MOD FAULT	O	3.3V LVCMOS			
38	MOD_ABS	Module Absent	O	3.3V LVCMOS	Absent	Present	Pull-Down ¹
40	RX_LOS	Receiver Loss of Signal	O	3.3V LVCMOS	Loss of Signal	OK	

Notes:

1. Pull-Down resistor (less than 100 ohm) is located within the CFP module.

Management Interface Pins (MDIO)

The CFP Module supports alarm, control and monitor functions via an MDIO bus. The CFP MDIO pins are listed in the following table.

Pin#	Symbol	Description	I/O	Logic	H	L	Pull-up/down
41	GLB_ALRMn	Global Alarm	O	3.3V LVCMOS	Ok	Alarm	
47	MDIO	Management Data Input Output Bi-Directional Data	I/O	1.2V LVCMOS			
48	MDC	MDIO Clock	I	1.2V LVCMOS			
46	PRTADR0	MDIO Physical Port address bit0	I	1.2V LVCMOS	per MDIO document		
45	PRTADR1	MDIO Physical Port address bit1	I	1.2V LVCMOS			
44	PRTADR2	MDIO Physical Port address bit2	I	1.2V LVCMOS			
43	PRTADR3	MDIO Physical Port	I	1.2V			

		address bit3		LVC MOS	
42	PRTADR4	MDIO Physical Port address bit4	I	1.2V LVC MOS	

Hardware Signaling Pin Timing Requirements

Timing Parameters for CFP hardware Signal Pins are listed in the following table.

Parameter	Symbol	Min	Max	Unit	Notes&Conditions
Hardware MOD_LOPWR assert	t_MOD_LOPWR_assert		10	ms	Application Specific May depend on current state Condition when signal is applied
TX Disable Assert Time	T_off		10	ms	

High Speed Clock Characteristics

100G CFP DCO use inner REFCLK, Customer do not need to provide this clock. The output TXMONCLK is not support and the RX MONCLK characteristics is shown below.

Items	Symbol	Min	Typ	Max	Units	Notes
Host Side RX_MONCLK (Optional)						
Impedance	Zd	80	100	120	Ω	Differential
RXMONCLK Frequency	Freq		931.75		MHz	OTU4
			859.4			100GE
Output Differential Voltage	V-out Differential	600		1200	mV-pp	OTU4
		600		1200		100GE
Return Loss	SDD22			-12	dB	
Clock Duty Cycle		40		60	%	

Mechanical Dimensions

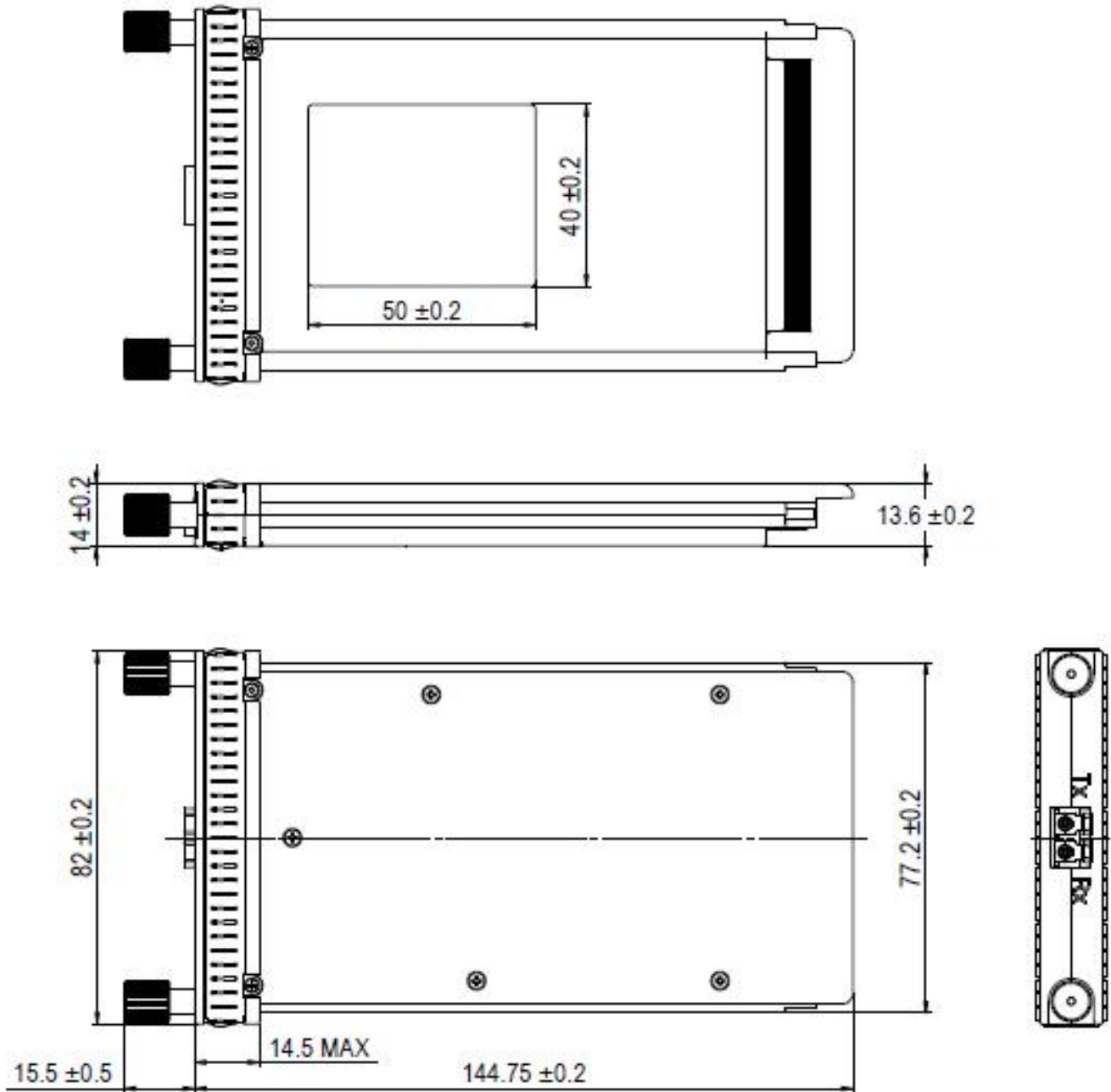

Unit: mm

Regulatory Compliance

FIBERSTAMP 100G CFP-DCO transponders are Class 1 Laser Products. They are certified per the following standards:

Feature	Standard
Laser Safety	IEC 60825-1:2014 (3 rd Edition)
Environmental protection	2011/65/EU
CE EMC	EN55032: 2015 EN55035: 2017 EN61000-3-2:2014 EN61000-3-3:2013
FCC	FCC Part 15, Subpart B; ANSI C63.4-2014

Ordering information

Part Number	Product Description
FSTCD-100G-LH-1	100G CFP-DCO LH, 100GE/OTU4, C-band 50GHz Tunable, 1200km, with EDFA

References:

- ✓ IEEE 802.3ba;
- ✓ ITU-T G.709/Y.1331
- ✓ RoHS 2.0 compliant (2011/65/EU, lead free)
- ✓ CFP-MSA-HW-Spec-rev1-40
- ✓ CFP_MSA_MIS_V2p6r06a
- ✓ CFP_MSA_Module-Dimensions_APRIL07-10
- ✓ CFP_MSA_Host-Mechanical-drawings
- ✓ OIF-MSA-100GLH-EM-02.1
- ✓ Regulation (EC) No.1907/2006(REACH)
- ✓ Tested in accordance with Telcordia GR-468
- ✓ IEC 60825-1:2014
- ✓ EN 60825-1:2014
- ✓ EN 60825-2:2004+A1+A2
- ✓ FDA CDRH 21 CFR 1040
- ✓ EN 60950-1:2006+A11+A1+A12+A2
- ✓ EN 62368-1: 2014+A11:2017
- ✓ UL 60950-1 & CAN/CSA C22.2 No. 60950-1
- ✓ UL 62368-1:2014

- ✓ IEC 60950-1:2005+AMD1:2009+AMD2:2013
- ✓ IEC 62368-1:2014
- ✓ GB 4943.1-2011
- ✓ 47 CFR FCC Part 15 Subpart B
- ✓ EN 55032:2015
- ✓ EN 55024:2010+A1:201

 **CAUTION:**

Use of controls or adjustment or performance of procedures other than those specified herein may result in hazardous radiation exposure.

Important Notice

This document contains information proprietary to FIBERSTAMP Corporation. Any use or disclosure, in whole or in part of this information to any unauthorized party, for any purpose other than that for which it is provided is expressly prohibited except as authorized by FIBERSTAMP in writing. FIBERSTAMP reserves the rights to pursue both civil and criminal penalties for copying or disclosure of this material without authorization. FIBERSTAMP reserve the rights add, delete and revise the content in this material without notice. The publication of information in this data sheet does not imply freedom from patent or other protective rights of FIBERSTAMP or others. Further details are available from any FIBERSTAMP sales representative.